

Catalogue
[2024]

DHWW

TANKS AND EQUIPMENT

DOMESTIC HOT WATER PRODUCTION AND STORAGE
for individual and communal installation and industrial applications.



STAINLESS STEEL TANKS

VITREOUS ENAMELLED STEEL TANKS

INERTIA BUFFER TANKS

lapesa 
1964-2024

A close-up photograph of water cascading from a metal pipe into a swimming pool. The water is clear and blue, creating a dynamic, flowing effect. The background is a soft-focus view of the pool's surface and the sky.

DOMESTIC HOT WATER

PRODUCTION AND
STORAGE

Proven quality, excellence in surface protection and maximum storage capacity.

lapesa

Solutions FOR YOUR COMFORT AND ECONOMY



DHWW

TANKS

FOR DOMESTIC HOT WATER
PRODUCTION AND STORAGE

50 to 12000 litres

for individual and communal installation
and industrial applications

STAINLESS STEEL TANKS

DHW PRODUCTION/STORAGE TANKS

GEISER INOX

domestic range
60 to 1000 litres



SERIES	MODELS	CAPACITIES DHW / TOTAL (l.)	STAINLESS STEEL MATERIAL	STANDARD DHW PRODUCTION TYPE/SYSTEM	OPTIONAL DHW PRODUCTION SYSTEM
GEISER INOX	GX6 S	60/90 to 500/600	AISI 316 L	DOUBLE WALL	
	GX6 TS	150/175 to 200/235	AISI 316 L	DOUBLE WALL	
	GX6 D	60/90 to 500/600	AISI 316 L	DOUBLE WALL	ELECTRIC HEATING ELEMENT
	GX6 DE	90/140 to 712/1000	AISI 316 L	DOUBLE WALL	ELECTRIC HEATING ELEMENT
	GX6 DEC	60/90 to 500/600	AISI 316 L	DOUBLE WALL + ELECTRIC HEATING ELEMENT	
	GX6 P	115/245 to 250/1000	AISI 316 L	DOUBLE WALL + COIL	ELECTRIC HEATING ELEMENT
	GX6 PAC	115/245 to 250/1000	AISI 316 L	DOUBLE WALL	ELECTRIC HEATING ELEMENT
	GX-...-R	200 to 1000	AISI 316 L	STORAGE	PLATE EXCHANGER/ELECTRIC HEATING ELEMENTS
	GX-...-RB	800 to 1000	AISI 316 L	STORAGE	PLATE EXCHANGER/ELECTRIC HEATING ELEMENTS
	GX-...-M1/M1B	200 to 1000	AISI 316 L	1 COIL	ELECTRIC HEATING ELEMENT
GX-...-TSC	100 to 150	AISI 316 L	1 COIL		
GX-...-TSM	150 to 200	AISI 316 L	1 COIL		
GX-...-M2/M2B	200 to 1000	AISI 316 L	2 COILS	ELECTRIC HEATING ELEMENT	
GX-...-HL/HLB	200 to 1000	AISI 316 L	OVERDIMENSIONED COIL	ELECTRIC HEATING ELEMENT	

HYDRAULIC INSTALLATION EXAMPLES
 DHW PRODUCTION
 ELECTRIC HEATING
 REGULATION AND CONTROL
 THERMAL INSULATION
 CATHODIC PROTECTION / ACCESSORIES

MASTER INOX

large capacity
1500 to 6000 litres



MXV-...-RB	1500 to 6000	AISI 316 L	STORAGE	PLATE EXCHANGER/ELECTRIC HEATING ELEMENTS
MXV-...-SB	1500 to 6000	AISI 316 L	DETACHABLE COIL	ELECTRIC HEATING ELEMENT
MXV-...-SSB	1500 to 6000	AISI 316 L	OVERDIMENSIONED DETACHABLE COIL	ELECTRIC HEATING ELEMENT
MXV-...-S2B	2000/3500/5000/6000	AISI 316 L	2 DETACHABLE COILS	ELECTRIC HEATING ELEMENT
MXV-...-SS2B	2000/3500/5000/6000	AISI 316 L	2 DETACHABLE COILS (LOWER ONE OVERDIMENSIONED)	ELECTRIC HEATING ELEMENT

DHW PRODUCTION
 ELECTRIC HEATING
 THERMAL INSULATION
 CATHODIC PROTECTION / ACCESSORIES / FINISHES IN ALUMINIUM ALUNOX
 HYDROMASTER SEMI-INSTANT DHW PRODUCTION UNITS

INDUSTRIAL CAPACITY STORAGE TANKS: 7000 to 12000 litres

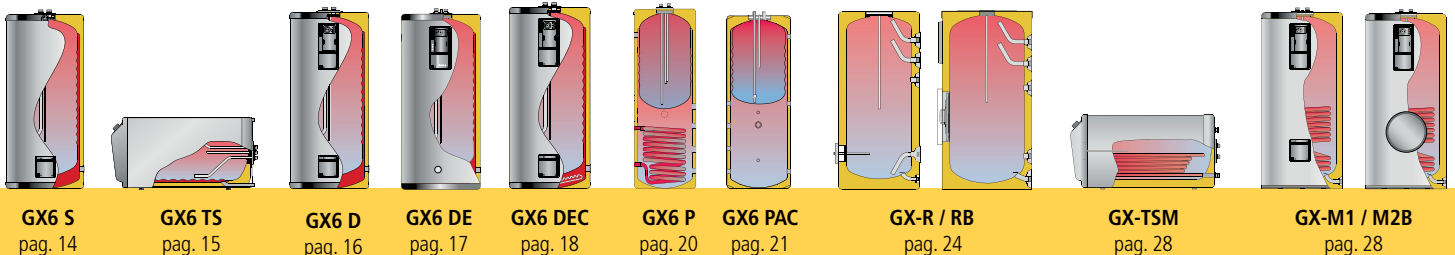

APPLICABLE ENERGY SOURCE

INDEX

HEAT PUMP	SOLAR COLLECTORS	GAS/FUEL OIL BOILER	SOLID FUELS BOILER	ELECTRIC HEATING ELEMENTS	SEVERAL COMBINED ENERGY SOURCES	PAGE
•	•	•				14
•	•	•				15
•	•	•		•	•	16
•	•	•		•	•	17
•	•	•		•	•	18
•	•	•	•	•	•	20
•	•	•	•	•	•	21
				•	•	24
				•	•	24
	•	•		•	•	28
	•	•			•	28
	•	•			•	29
	•	•		•	•	29
•	•	•		•	•	30
						31
						32
						38
						40
						41
						42
				•	•	47
	•	•		•	•	51
•	•	•		•	•	52
	•	•		•	•	53
•	•	•		•	•	53
						54
						58
						60
						61
						134
						128



GX-M2 / M2B
pag. 29

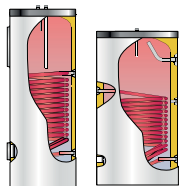

GX-HL / HLB
pág. 30

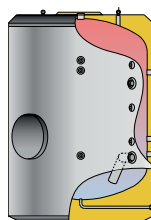

MXV -RB
pag. 47

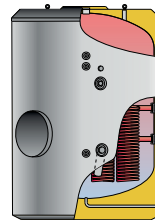

MXV-SB / SSB
pag. 51 / 52

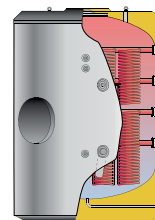

MXV-S2B / SS2B
pag. 53

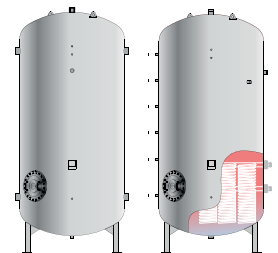

INDUSTRIAL CAPACITY
pag. 130

VITREOUS ENAMELLED STEEL TANKS

DHW PRODUCTION/STORAGE TANKS

SERIES	MODELS	CAPACITIES DHW / TOTAL (l.)	STEEL MATERIAL	STANDARD DHW PRODUCTION TYPE/SYSTEM	OPTIONAL DHW PRODUCTION SYSTEM
CORAL VITRO domestic range 80 to 1500 litres	CV-...-R	200 to 1000	S275JR	STORAGE	PLATE EXCHANGER / ELECTRIC HEATING ELEMENTS
	CV-...-RB	800 to 1500	S275JR	STORAGE	PLATE EXCHANGER / ELECTRIC HEATING ELEMENTS
	CV-...-M1S	80 to 300	S275JR	COIL	ELECTRIC HEATING ELEMENTS
	CV-...-M1M	90 to 160	S275JR	COIL	ELECTRIC HEATING ELEMENTS
	CV-...-M1/M1B	200 to 1500	S275JR	COIL	ELECTRIC HEATING ELEMENTS
	CV-...-M2/M2B	300 to 1000	S275JR	2 COILS	ELECTRIC HEATING ELEMENTS
	CV-...-HL/HLB	200 to 1000	S275JR	OVERDIMENSIONED COIL	ELECTRIC HEATING ELEMENTS
	CV-...-HLDUO	350	S275JR	OVERDIMENSIONED COIL	ELECTRIC HEATING ELEMENTS
	CV-...-P	150/600 to 200/1000	S275JR	DOUBLE WALL + COIL	ELECTRIC HEATING ELEMENTS
	CV-...-P-DUO	150/600 to 200/1000	S275JR	DOUBLE WALL + COIL	ELECTRIC HEATING ELEMENTS

DHW PRODUCTION
ELECTRIC HEATING
REGULATION AND CONTROL
THERMAL INSULATION
CATHODIC PROTECTION / ACCESSORIES

MASTER VITRO large capacity 1500 to 6000 litres	MVV-...-RB	1500 to 6000	S275JR	ACCUMULATION	ÉCHANGEUR À PLAQUES / RÉSISTANCES ÉLECTRIQUES
	MVV-...-SB	1500 to 6000	S275JR	DETACHABLE COIL	ELECTRIC HEATING ELEMENTS
	MVV-...-SSB	1500 to 6000	S275JR	OVERDIMENSIONED DETACHABLE COIL	ELECTRIC HEATING ELEMENTS
	MVV-...-S2B	2000/3500/5000/6000	S275JR	2 DETACHABLE COILS	ELECTRIC HEATING ELEMENTS
	MVV-...-SS2B	2000/3500/5000/6000	S275JR	2 DETACHABLE COILS (LOWER ONE OVERDIMENSIONED)	ELECTRIC HEATING ELEMENTS

DHW PRODUCTION
ELECTRIC HEATING
THERMAL INSULATION
CATHODIC PROTECTION / ACCESSORIES
FINISHES IN ALUMINIUM ALUNOX

HYDROMASTER SEMI-INSTANT DHW PRODUCTION UNITS

INDUSTRIAL CAPACITY STORAGE TANKS IN COATED STEEL: 7000 to 12000 litres

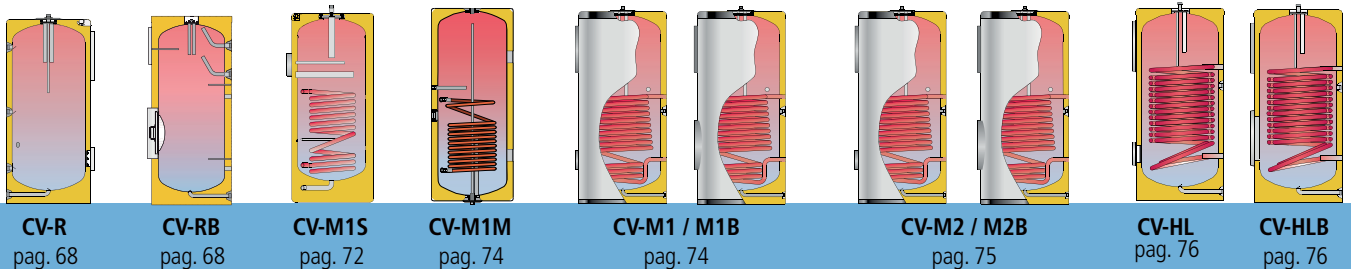

APPLICABLE ENERGY SOURCE

INDEX

HEAT PUMP	SOLAR COLLECTORS	GAS/FUEL OIL BOILER	SOLID FUELS BOILER	ELECTRIC HEATING ELEMENTS	SEVERAL COMBINED ENERGY SOURCES	PAGE
				•	•	68
				•	•	68
	•	•		•	•	72
	•	•		•	•	73
	•	•		•	•	74
	•	•		•	•	75
•	•	•		•	•	76
•	•	•		•	•	77
•	•	•	•	•	•	80
•	•	•	•	•	•	81
						82
						86
						88
						89
						90
				•	•	94
	•	•		•	•	98
•	•	•		•	•	99
	•	•		•	•	100
•	•	•		•	•	100
						102
						106
						108
						109
						109
						134
						128

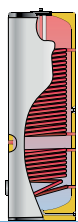

CV-HLDUO
pag. 77

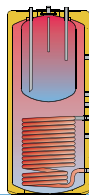

P
pag. 80

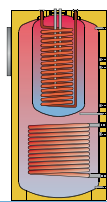

P/DUO
pag. 81

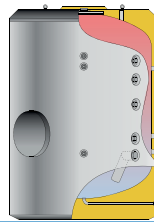

MVV-RB
pag. 94

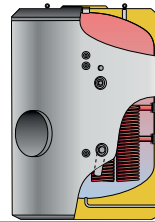

MVV-SB / SSB
pag. 98 / 99

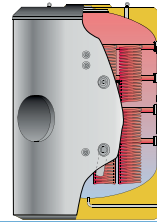

MVV-S2B / SS2B
pag. 100

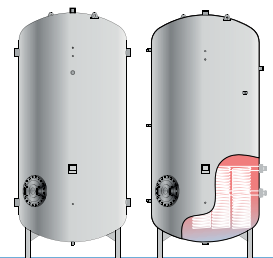

INDUSTRIAL CAPACITY
pag. 131

INERTIA TANKS

BUFFER TANKS FOR PRIMARY CIRCUITS

SERIES

GEISER INERTIE
domestic range
30 to 1000 litres



MODELS	CAPACITIES (l.)	STEEL MATERIAL	STANDARD HW PRODUCTION TYPE/SYSTEM	OPTIONAL HW PRODUCTION SYSTEM
G-...-I	370 to 1500	S235JR	STORAGE	ELECTRIC HEATING ELEMENT
G-...-IF	30 to 1500	S235JR	STORAGE	ELECTRIC HEATING ELEMENT
GX4-...-I/F	80 to 1000	AISI 304L	STORAGE	ELECTRIC HEATING ELEMENT
G-...-IS	370 to 1500	S235JR	STORAGE / COIL	ELECTRIC HEATING ELEMENT
G-...-IFS	260 to 1500	S235JR	STORAGE / COIL	ELECTRIC HEATING ELEMENT
G-...-L	800 to 1500	S235JR	STORAGE / STRATIFICATION	ELECTRIC HEATING ELEMENT
G-...-LW	800 to 1500	S235JR	COIL / STRATIFICATION	ELECTRIC HEATING ELEMENT

THERMAL INSULATION
ACCESSORIES

MASTER INERTIE
large capacity
1500 to 6000 litres



MV-...-I	1500 to 5000	S235JR	STORAGE	ELECTRIC HEATING ELEMENTS
MV-...-IB	1500 to 6000	S235JR	STORAGE	ELECTRIC HEATING ELEMENTS
MXV4-...-I	1500 to 6000	AISI 304L	STORAGE	ELECTRIC HEATING ELEMENTS
MXV4-...-IB	1500 to 6000	AISI 304L	STORAGE	ELECTRIC HEATING ELEMENTS
MV-...-IS	1500 to 5000	S235JR	COIL	ELECTRIC HEATING ELEMENT
MV-...-ISB	1500 to 5000	S235JR	COIL	ELECTRIC HEATING ELEMENT
MV-...-L	2000 to 5000	S235JR	STORAGE / STRATIFICATION	ELECTRIC HEATING ELEMENT

THERMAL INSULATION
ACCESSORIES

FINISHES IN ALUMINIUM ALUNOX

INDUSTRIAL CAPACITY INERTIA TANKS: 7000 to 12000 litres

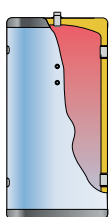

G-I
pag. 116

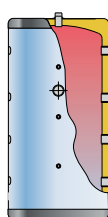

G-I/IF
pag. 116

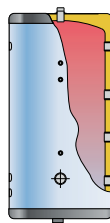

GX4-IF (AISI-304)
page 116

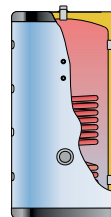

G-IS / G-IFS
pag. 118

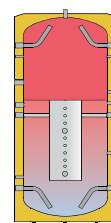



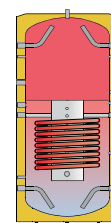



G-L
pag.122



G-LW
pag. 123

APPLICABLE ENERGY SOURCE

INDEX

 HEAT PUMP	 SOLAR COLLECTORS	 GAS/FUEL OIL BOILER	 SOLID FUELS BOILER	 ELECTRIC HEATING ELEMENTS	 SEVERAL COMBINED ENERGY SOURCES	PAGE
•	•	•	•	•	•	116
•	•	•	•	•	•	116
•	•	•	•	•	•	116
•	•	•	•	•	•	118
•	•	•	•	•	•	118
•	•	•	•	•	•	122
•	•	•	•	•	•	123
						126
						127
•	•	•	•	•	•	117
•	•	•	•	•	•	117
•	•	•	•	•	•	117
•	•	•	•	•	•	117
•	•	•	•	•	•	119
•	•	•	•	•	•	119
•	•	•	•	•	•	124
						126
						127
						127
						128

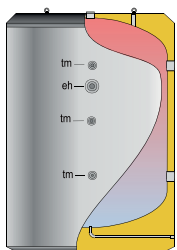

MV-I / MXV4-I (AISI-304)
page 117

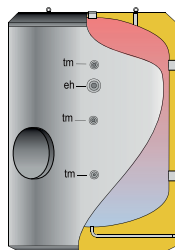

MV-IB / MXV4-IB (AISI-304)
page 117

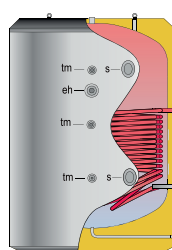

MV-IS / ISB
pag. 119

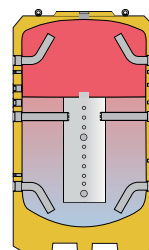

MV-L
pag. 124



INDUSTRIAL CAPACITY
pag. 132



GEISER INOX - MASTER INOX
 the stainless steel solution!

*Chromium-nickel-molibdenum **STAINLESS STEEL**, highly resistant to pitting caused by halogen elements such as the chlorine present in drinking water, is the material used to manufacture all of the models in our "GEISER INOX" and "MASTER INOX" series.*

HYGIENIC MATERIAL: Easy to clean, it allows the use of very energetic washing and disinfecting means (e.g. anti-legionella treatments) without undergoing any changes. In DHW tanks made of stainless steel there is no accumulation of residues from sacrificial anodes because the tanks do not require cathodic protection in normal working conditions.

FOOD GRADE: Stainless steel is a non-toxic material that is commonly used in the food industry. In hygiene tests it is on a par with glass and porcelain and is thus considered ideal for use in the manufacture of tanks intended for the production and storage of domestic hot water.

MAXIMUM WORKING TEMPERATURE: It withstands the maximum DHW storage temperatures handled by this type of facilities (90°C) without undergoing any change.

LONG SERVICE LIFE: Amongst the stainless steels used for these products, **AISI 316 L stainless steel** has one of the highest levels of corrosion resistance. By way of example AISI 316 L stainless steel withstands twice as much dissolved chloride in water content than AISI 304 L steel in the same working conditions.

Cathodic protection is not required. The "GEISER and MASTER INOX" series of storage tanks do not require cathodic protection in normal conditions of use for drinking water (European Directive 98/83/CE). In the case of water which is particularly aggressive due to its chemical composition, the storage tanks supplied with lapesa correx-up permanent, maintenance-free cathodic protection.

High mechanical strength: The stainless steel withstands the mechanical stress caused by sudden fluctuations in pressure, water hammer effects of pumps, etc. without any problems or risk of damage.

EXCEPTIONAL PRODUCT QUALITY: The best-kept secret. The process employed in the manufacture of our stainless steel storage tanks is the key to their success as products of proven quality. The special welding procedures used in their manufacture and the subsequent pickling and passivation of metal surfaces, which is subject to strict quality controls, endows our products with a quality that puts them at the very highest market level. This level of quality is underpinned by our products' worldwide presence for more than 30 years.

OPTIMIZED DESIGN. BEST VALUE FOR MONEY: Design and features. The wide range of models in

our **"GEISER INOX and MASTER INOX"** series, leverages the many design options that stainless steel affords, endowing our products with the best performance features. Excellent product value-for-money comes from optimizing the design and the manufacturing process for each model.

Double-wall models with electric heating incorporated in the primary heating circuit, maintenance-free, specific high-performance models to ensure the best possible use of **RENEWABLE ENERGIES**, models for low-temperature, mixed, communal, individual or battery installations are only some of the possibilities provided by the variety of designs in our range.

The level of quality of a stainless steel tank mainly depends on the quality and execution of the manufacturing processes, well as on the design of the storage tank and the quality of the stainless steel used. The success of lapesa products is closely linked to the combination of these three aspects



APPLICABLE DIRECTIVES AND STANDARDS:

Directive 2014/68/UE: European Pressure Equipment Directive.

Royal Decree 865/2003 establishing hygiene-health criteria for the prevention and control of Legionnaires' disease.

Regulation on thermal installations in buildings (RITE) and its accompanying technical instructions.

UNE 100030:2005 IN STANDARD: Guide for the prevention and control of the proliferation and dissemination of legionella in installations.

UNE 112076:2004 IN STANDARD: Prevention of corrosion in water circuits.

APPLICATIONS

GEISER INOX

- Individual installations for the production/storage of DHW
- Single-family homes
- Gymnasiums and sports centres
- Clinics and hospitals
- Laboratories
- Restaurants, hotels, bars
- Laundries
- Schools and universities
- Solar and other renewable energy installations
- DHW centralized systems (battery installation)

MASTER INOX

- Individual production/storage installations with large DHW consumptions
- Collective housing
- Gymnasiums and sports centres
- Clinics and hospitals
- Laboratories
- Restaurants, cafeterias, bars
- Hotels
- Laundries
- Schools and universities
- Solar and other renewable energy installations
- Industrial installations (individual or battery installation)
- Large DHW consumptions (individual or battery installation)
- Centralized DHW systems in buildings (individual or battery installation)





GEISER INOX - STAINLESS STEEL

DOUBLE WALL models - nothing but advantages!

The water contained in the surrounding tank or primary tank is heated by an external energy source (boiler, heat pump, solar collectors, etc.) that passes through this vessel and transmits its thermal energy to the water contained in the inner tank or DHW storage tank.



DOUBLE-WALL TANKS: This is the star product of the "GEISER INOX" series thanks its many advantages over conventional DHW production systems.

The DOUBLE-WALL system basically consists of a combination of two tanks, one inside the other. DHW production takes place by the exchange of heat from the external or primary tank to the internal or secondary tank (DHW), throughout the whole of the tank's surface.

The water contained in the surrounding tank or primary tank is heated by an external energy source (boiler, heat pump, solar collectors, etc.) that passes through this vessel and transmits its thermal energy to the water contained in the inner tank or DHW storage tank.

DHW PRODUCTION/STORAGE TANKS GEISER INOX - **DOUBLE WALL**

lapesa

LONG-LASTING PRODUCT: Nickel-chromium-molybdenum **STAINLESS STEEL** DHW storage tank, highly resistant to pitting caused by halogen elements such as chlorine in drinking water. This is the material used to manufacture all of the models in our "GEISER INOX" series.

SELF-CLEANING EFFECT: Corrugated design of the DHW storage tank, in constant vertical movement depending on the fluctuations in the internal pressure, which helps to detach any limescale from the walls.

ANTI LEGIONELLA DESIGN: Totally uniform DHW storage temperature, with no cold zones inside the storage tank. The surround heating of DHW produces a uniform water storage temperature throughout the whole of the tank, which in turn allows it to be used to its full capacity.

MAINTENANCE-FREE: DHW tank without any internal heat exchange elements. It does not require cathodic protection in normal drinking water conditions. The models with electric heating have the heating element in the primary circuit so there is no risk of corrosion or lime scale.

LARGE DHW PRODUCTION CAPACITY: The heat exchange area is that of the total surface area of the DHW storage tank.

MAXIMUM STORAGE CAPACITY: Extra thick, rigid, PU mould-injected insulation that minimizes heat losses of stored DHW (see HEAT INSULATION chapter, page: 41)

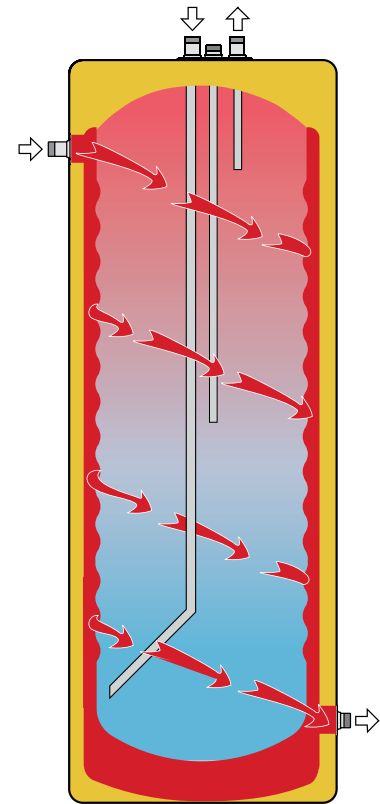

DOUBLE WALL TANKS HEATING SYSTEM



FEATURES COMMON TO ALL "DOUBLE-WALL GEISER INOX" MODELS:

- DHW storage tanks in **AISI 316 L stainless steel**
- DHW capacities: **60, 100, 150, 200, 300 and 500 litres**
- Maximum working pressure of DHW storage tank: **8 bar** (10 bar optional)
- Maximum working temperature of DHW storage tank: **90 °C**
- Maximum working pressure of surrounding tank (primary circuit): **3 bar**
- Maximum working temperature of surrounding tank (primary circuit): **110 °C**
- Thermal insulation: **Rigid, mould-injected PU** (CFC/HCFC-free, 0.025 W/m²K)
- **VERTICAL** or **HORIZONTAL** installation. Up to 150 litres, ready for **WALL MOUNTING** (except TS models)

GEISER INOX "S"

DOUBLE-WALL storage tank for the production of DHW by heat exchange between the surrounding tank (primary circuit) and the internal tank (DHW), via an external energy source (boiler, solar panels, heat pump, etc.).

Finish: RAL 9016 white external lining and RAL 7021 grey cover.

For VERTICAL or HORIZONTAL installation.

Designed for wall mounting, up to GX6 S190 model.

EQUIPMENT:

DHW thermometer on top cover. Brackets for wall mounting, up to GX6 S190 model.

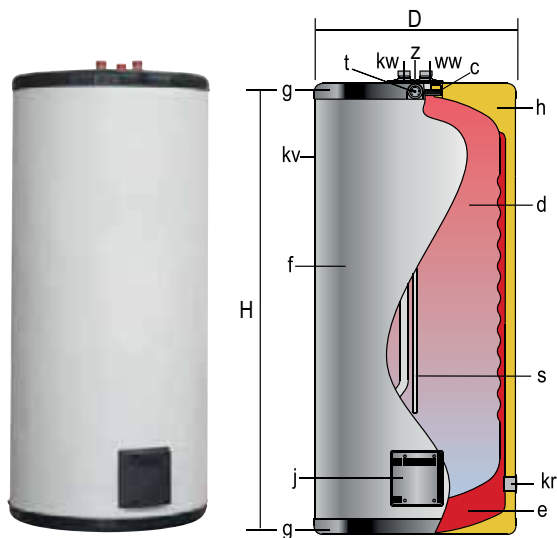

c - inspection hole
d - DHW tank
e - heating chamber
f - external lining
g - cover
h - thermal insulation
j - side hole
s - probe tube for sensors
t - thermometer

GENERAL CHARACTERISTICS		GX6 S90	GX6 S130	GX6 S190	GX6 S260	GX6 S400	GX6 S600
Total capacity	l.	82	130	191	256	365	608
DHW capacity	l.	60	100	150	200	300	500
Primary HW capacity	l.	22	30	41	56	65	108
D: external diameter	mm.	480	480	620	620	620	770
H: overall height	mm.	750	1155	985	1240	1725	1730
kw: cold water inlet / drain	" GAS/M	3/4	3/4	3/4	3/4	1	1
ww: DHW outlet	" GAS/M	3/4	3/4	3/4	3/4	1	1
z: Recirculation	" GAS/M	3/4	3/4	3/4	3/4	1	1
kv: primary input	" GAS/F	1	1	1	1	1	1 1/2
kr: primary return	" GAS/F	1	1	1	1	1	1 1/2
Heat exchange surface	m ²	0,8	1,2	1,2	1,6	2,4	3
Empty weight (approx.)	Kg	34	50	63	76	105	149

DHW PRODUCTION/STORAGE TANKS

GEISER INOX - **DOUBLE WALL**

GEISER INOX "TS"

DOUBLE-WALL storage tank for the production of DHW by heat exchange between the surrounding tank (primary circuit) and the internal tank (DHW), via an external energy source (boiler, solar panels, heat pump, etc.). Specifically designed for **HORIZONTAL INSTALLATION**.

Finish: RAL 9016 white external lining and black covers.

Able to withstand the weight of a boiler of up to 700 kg on top.

EQUIPMENT:

Thermometer & DHW regulation thermostat on front cover.

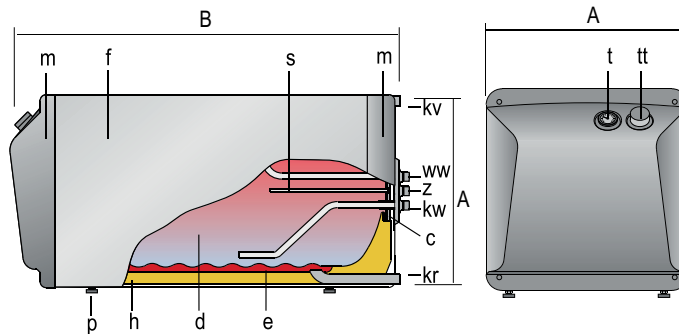

GENERAL CHARACTERISTICS		GX6 TS180	GX6 TS240
Total capacity	l.	175	233
DHW capacity	l.	150	200
Primary HW capacity	l.	25	33
A: height / width	mm.	630	630
B: length	mm.	1.000	1.225
kw: cold water inlet / drain	" GAS/M	3/4	3/4
ww: DHW outlet	" GAS/M	3/4	3/4
z: recirculation	" GAS/M	3/4	3/4
kv: primary input	" GAS/F	1	1
kr: primary return	" GAS/F	1	1
Heat exchange surface	m ²	1,2	1,6
Empty weight (approx.)	Kg	66	85

- c - inspection hole
- d - DHW tank
- e - heating chamber
- f - external lining
- h - thermal insulation
- m - side covers
- p - leveling feet
- s - probe tube for sensors
- t - thermometer
- tt - thermostat

GEISER INOX "D"

DOUBLE-WALL storage tank for the production of DHW by means of heat exchange between the surrounding tank (primary circuit) and the internal tank (DHW), via an external energy source (boiler, solar panels, heat pump, etc.).

Equipped with side hole in primary circuit for **optional incorporation of electric heating element**.

Finish: RAL 9016 white external lining and RAL 7021 grey cover.

For VERTICAL or HORIZONTAL installation (under request, see page 18)
(except TS models)

Designed for wall mounting, up to GX6 D190 model.

EQUIPMENT:

"K" control panel, wired and mounted, with thermometer, dual safety and control thermostat, winter-summer switch and LEDs.

OPTIONAL: "KP1" control panel with analog time switch for electric heating.

Brackets for wall mounting, up to model GX6 D190.

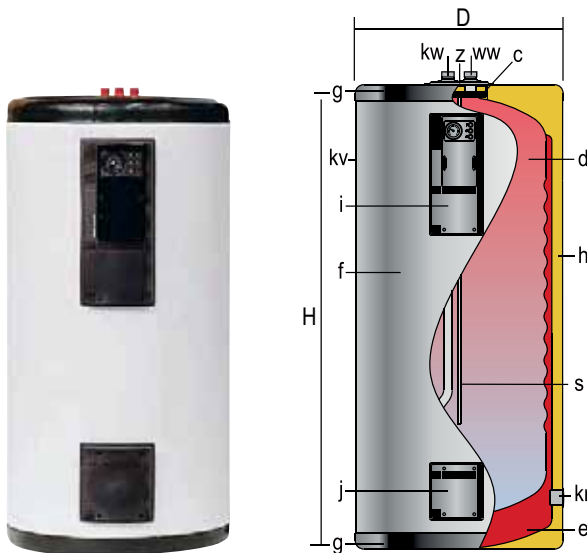

- c - inspection hole
- d - DHW tank
- e - heating chamber
- f - external lining
- g - cover
- h - thermal insulation
- i - control panel
- j - side hole
- s - probe tube for sensors
- t - thermometer

GENERAL CHARACTERISTICS		GX6 D90	GX6 D130	GX6 D190	GX6 D260	GX6 D400	GX6 D600
Total capacity	l.	82	130	191	256	365	608
DHW capacity	l.	60	100	150	200	300	500
Primary HW capacity	l.	22	30	41	56	65	108
D: external diameter	mm.	480	480	620	620	620	770
H: overall height	mm.	750	1155	985	1240	1725	1730
kw: cold water inlet / drain	" GAS/M	3/4	3/4	3/4	3/4	1	1
ww: DHW outlet	" GAS/M	3/4	3/4	3/4	3/4	1	1
z: Recirculation	" GAS/M	3/4	3/4	3/4	3/4	1	1
kv: primary input	" GAS/F	1	1	1	1	1	1 1/2
kr: primary return	" GAS/F	1	1	1	1	1	1 1/2
Heat exchange surface	m ²	0,8	1,2	1,2	1,6	2,4	3
Control panel	model	K	K	K	K	K	K
Empty weight (approx.)	Kg	36	52	65	78	107	151

GEISER INOX "DE"

DOUBLE-WALL storage tank for the production of DHW by means of heat exchange between the surrounding tank (primary circuit) and the internal tank (DHW), via an external energy source (boiler, solar panels, heat pump, etc.). Equipped with side threaded connection in primary circuit for **optional incorporation of an "RI"-type THREADED electric heating element**.

Finish: RAL 9016 white external lining and RAL 7021 grey cover.
For VERTICAL installation.

EQUIPMENT:

"K" control panel, wired and mounted, with thermometer, dual safety and control thermostat, winter-summer switch and LEDs.

OPTIONAL: "KP1" control panel with analog time switch for electric heating.

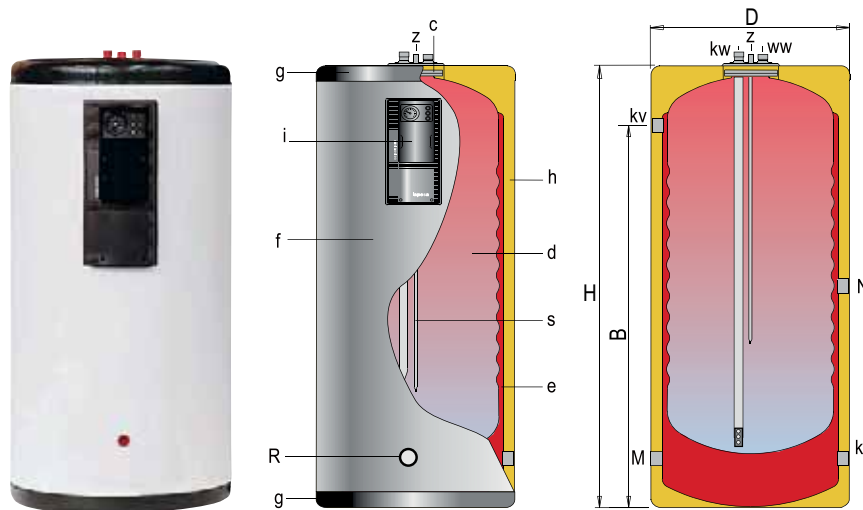

- c - Top inspection hole
- d - DHW tank
- e - Heating chamber
- f - Outer lining
- g - Cover
- h - Thermal insulation
- i - Control panel
- s - Probe tube for sensors

GENERAL CHARACTERISTICS		GX6 DE140	GX6 DE180	GX6 DE215	GX6 DE260	GX6 DE400	GX6 DE600	GX6 DE1000
Total capacity	l.	138	176	214	252	355	574	955
DHW capacity	l.	92	127	161	196	265	433	712
Primary HW capacity	l.	46	49	53	56	90	141	243
D: external diameter	mm.	560	560	560	560	620	770	950*
H: overall height	mm.	1030	1280	1530	1780	1725	1730	2250
kw: cold water inlet / drain	" GAS/M	3/4	3/4	3/4	3/4	1	1	1
ww: DHW outlet	" GAS/M	3/4	3/4	3/4	3/4	1	1	1
z: Recirculation	" GAS/M	3/4	3/4	3/4	3/4	1	1	1
kv: primary input	" GAS/F	1	1	1	1	1 1/2	1 1/2	1 1/2
kr: primary return	" GAS/F	1	1	1	1	1 1/2	1 1/2	1 1/2
R: connection for electric heating element	" GAS/F	2	2	2	2	2	2	2
N: primary side connection	" GAS/F	-	1	1	1	1 1/2	1 1/2	-
M: primary side connection	" GAS/F	1	1	1	1	1 1/2	1 1/2	1 1/2
Heat exchange surface	m ²	0,9	1,2	1,6	1,9	2,2	2,8	4
Control panel	model	K	K	K	K	K	K	K
Empty weight (approx.)	Kg	50	67	90	97	106	150	239

(*) Insulation system allows passing through 800 mm wide doors.

GEISER INOX "DEC"

DOUBLE-WALL storage tank for the production of DHW by means of heat exchange between the surrounding tank (primary circuit) and the internal tank (DHW), via an external energy source (boiler, solar panels, heat pump, etc.).

Equipped with side hole in primary circuit, with **factory-mounted electric heating element**.

Finish: RAL 9016 white external lining and RAL 7021 grey cover.

EQUIPMENT:

Full electric heating unit, factory-mounted and wired, comprising electric heating element and "K" control panel, with thermometer, dual safety and control thermostat, winter-summer switch and LEDs.

Brackets for wall mounting, up to model GX6 DEC190.

OPTIONAL: "KP1" control panel with analog time switch for electric heating.

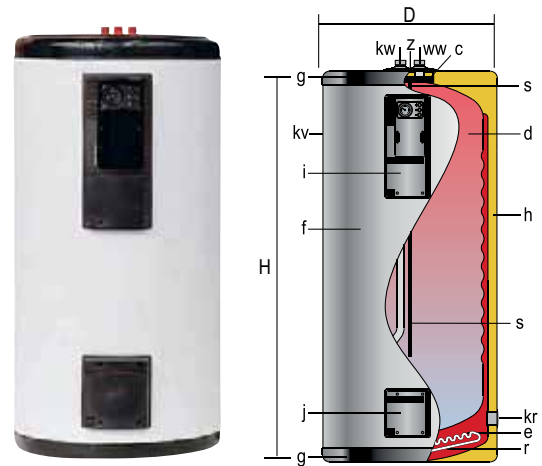

c - Inspection hole
d - DHW tank
e - Heating chamber
f - External lining

g - Cover
h - Thermal insulation
i - Control panel
j - Side hole

s - Probe tube for sensors
r - Electric heating element



GENERAL CHARACTERISTICS		GX6 DEC90	GX6 DEC130	GX6 DEC190	GX6 DEC260	GX6 DEC400	GX6 DEC600
Total capacity	l.	82	130	191	256	365	608
DHW capacity	l.	60	100	150	200	300	500
Primary HW capacity	l.	22	30	41	56	65	108
D: external diameter	mm.	480	480	620	620	620	770
H: overall height	mm.	750	1155	985	1240	1725	1730
kw: cold water inlet / drain	" GAS/M	3/4	3/4	3/4	3/4	1	1
ww: DHW outlet	" GAS/M	3/4	3/4	3/4	3/4	1	1
z: Recirculation	" GAS/M	3/4	3/4	3/4	3/4	1	1
kv: primary input	" GAS/F	1	1	1	1	1	1 1/2
kr: primary return	" GAS/F	1	1	1	1	1	1 1/2
Heat exchange surface	m ²	0,8	1,2	1,2	1,6	2,4	3
Control panel	model	K	K	K	K	K	K
Electric heating element (factory mounted)	kW	1,5	2,2	2,2	2,5	2,5	4,5
Empty weight (approx.)	Kg	37	53	67	80	109	153

WALL INSTALLATION: Double wall "GEISER INOX" models up to 190 litres total capacity can be WALL-MOUNTED. The necessary anchors are supplied with the tanks (see installation and mounting instructions).

VERTICAL POSITION: All double wall "GEISER INOX" tanks are supplied ready to be installed in VERTICAL position, with the hydraulic connections of their inner (DHW) tank on the top flange.

HORIZONTAL POSITION*: All double wall "GEISER INOX" tanks can be installed in HORIZONTAL position (except "DE), with a special plate for the hydraulic connections of the inner (DHW) tank mounted on factory upon request. The specific type of horizontal installation must be chosen, either "HORIZONTAL LEFT" or "HORIZONTAL RIGHT", according to the position of the hydraulic connections of the inner (DHW) tank.

ELECTRIC HEATING IN HORIZONTAL INSTALLATION:

The electric heating elements for HORIZONTAL installation must be ordered specifically according to the tank orientation:

- Electric heating element RC..I for horizontal left tank orientation.
- Electric heating element RC..D for horizontal right tank orientation.

For VERTICAL installations, both types of electric heating elements are valid.

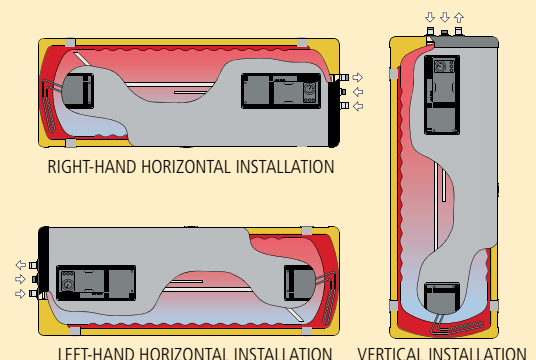

*If the decision for installing a tank in horizontal position occurs after the reception of a standard model, a specific KIT of "plate with DHW hydraulic connections for horizontal installation" can be supplied, and installed in tank on site.

nothing but advantages!

Models DOUBLE WALL

- STAINLESS STEEL STORAGE TANK
- LARGE DHW PRODUCTION CAPACITY
- SELF-CLEANING EFFECT
- ANTI-LEGIONELLA DESIGN
- MAXIMUM STORAGE CAPACITY
- MAINTENANCE-FREE



GEISER INOX "P"

"DOUBLE-WALL" tanks termed "**MULTIFUNCTIONAL**" are known as such since several different energy sources can be installed for one single tank. Just like in the previous systems, DHW production is carried out by heat exchange between the primary (external) circuit and the DHW (internal) tank via several external energy sources (boiler, solar panels, heat pump, electric heating element, etc.) simultaneously coupled to the tank.

These tanks have a large capacity primary circuit that acts as a thermal inertia buffer (for solid fuel or biomass boilers and/or heat pump), which houses a coil with a large heat exchange surface, specially designed for solar energy.

Tanks for VERTICAL installation on floor.

The P800 and P1000 models incorporate an insulation system, which allows pass through doors of 800 mm. wide.

Finish: RAL 9016 white external lining and RAL 7021 grey cover.

EQUIPMENT:

"S" panel with DHW thermometer. OPTIONAL: "K", "KP1", "BC" control panels (see REGULATION AND CONTROL chapter, page: 40)

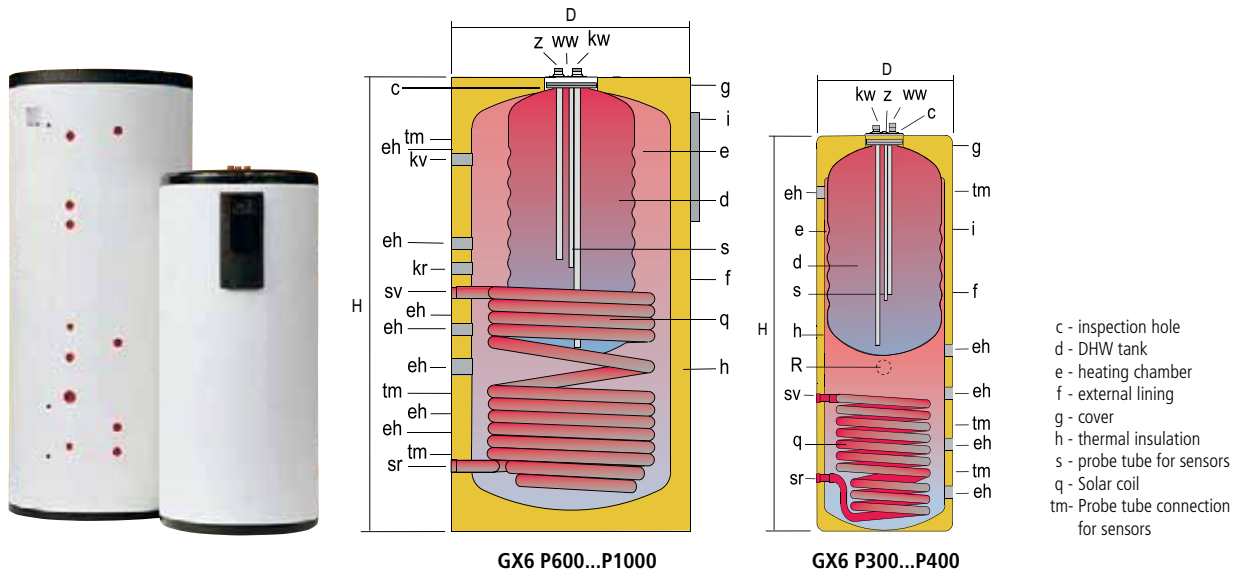

GENERAL CHARACTERISTICS		GX6 P300	GX6 P400	GX6 P600	GX6 P800	GX6 P1000
Total capacity	l.	244	341	605	770	970
DHW capacity	l.	116	147	215	200	250
Primary HW capacity	l.	128	194	390	570	720
D: external diameter	mm.	560	620	770	950	950
H: overall height	mm.	1770	1725	1730	1840	2250
kw: cold water inlet / drain	" GAS/M	3/4	3/4	3/4	3/4	3/4
ww: DHW outlet	" GAS/M	3/4	3/4	3/4	3/4	3/4
z: DHW recirculation	" GAS/M	3/4	3/4	3/4	3/4	3/4
kv: primary input	" GAS/F	-	-	1 1/4	1 1/4	1 1/4
kr: primary return	" GAS/F	-	-	1 1/4	1 1/4	1 1/4
sv: coil inlet	" GAS/F	1	1	1	1	1
sv: coil return	" GAS/F	1	1	1	1	1
eh: side connection	" GAS/F	1 1/4	1 1/4	1 1/4	1 1/4	1 1/4
R: electric element connection	" GAS/F	2	2	2	2	2
Heat exchange surface	m ²	1,7	1,8	2,4	2,7	2,7
Control panel	model	S	S	S	S	S
Empty weight (approx.)	Kg	88	127	185	245	290

GEISER INOX "PAC"

"DOUBLE WALL" tanks specifically designed for the application of **RENEWABLE ENERGIES** (installation with heat pump, solid fuel or biomass boilers).

These tanks have a large capacity primary circuit that acts as an inertia buffer, combining both functions -**inertia buffer and DHW tank**-.

Just like the previous systems, DHW production is carried out by heat exchange between the primary circuit (external) tank and the DHW (internal) tank.

Tanks for VERTICAL installation on floor.

Ready to incorporate an electric heating element.

The PAC800 and PAC1000 models incorporate an insulation system, which allows pass through doors of 800 mm. wide. Finish: RAL 9016 white external lining and RAL 7021 grey cover.

EQUIPMENT:

"S" panel with DHW thermometer. Optional: "K", "KP1", "BC" control panels (see REGULATION AND CONTROL chapter, page: 40)

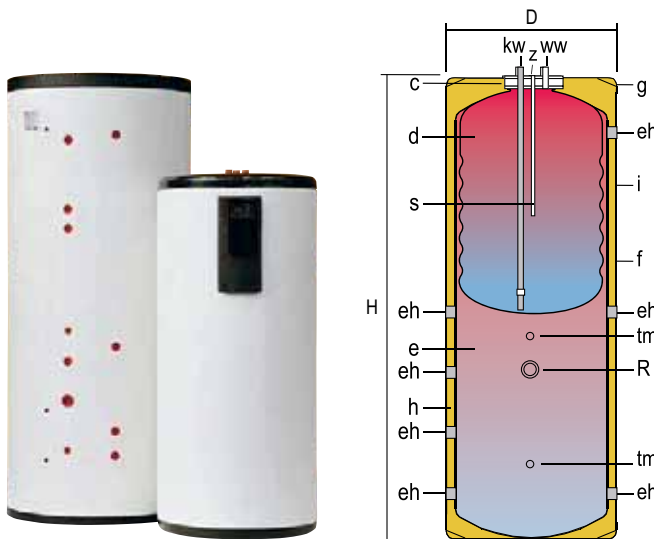

- c - inspection hole
- d - DHW tank
- e - heating chamber
- f - external lining
- g - cover
- h - thermal insulation
- i - control panel
- s - probe tube for sensors
- tm- connection for sensors probe tube

GENERAL CHARACTERISTICS		GX6 PAC300	GX6 PAC400	GX6 PAC600	GX6 PAC800	GX6 PAC1000
Total capacity	l.	244	341	605	770	970
DHW capacity	l.	116	147	277	200	250
Primary HW capacity	l.	128	194	328	570	720
D: external diameter	mm.	560	620	770	950	950
H: overall height	mm.	1770	1725	1730	1840	2250
kw: cold water inlet / drain	" GAS/M	3/4	3/4	3/4	3/4	3/4
ww: DHW outlet	" GAS/M	3/4	3/4	3/4	3/4	3/4
z: DHW recirculation	" GAS/M	3/4	3/4	3/4	3/4	3/4
eh: side connection	" GAS/F	1 1/4	1 1/4	1 1/4	1 1/4	1 1/4
R: electric element connection	" GAS/F	2	2	2	2	2
Control panel	model	S	S	S	S	S
Empty weight (approx.)	Kg	72	85	125	217	262



GEISER INOX - STAINLESS STEEL

STORAGE models, energy savings!

Designed to provide maximum energy storage capacity, with over-dimensioned rigid, mould-injected PU thermal insulation, these models maintain the DHW storage temperature for a long time without the need for any additional energy input, affording users continued savings throughout the storage tank's service life.

STORAGE TANKS: Designed to provide an extraordinary storage capacity that translates directly into real savings.

The overdimensioned, rigid, mould-injected PU thermal insulation maintains the DHW storage temperature over long periods of time without requiring additional energy input. This means less start-ups and adjustments of external energy sources, which in turn translates into less energy consumption.

Storage tanks without their own heat exchange system, designed for the installation of plate heat exchangers and/or electric immersion elements as the heating source.



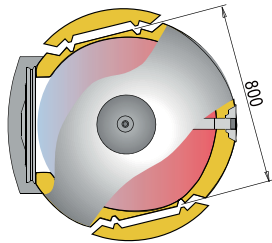
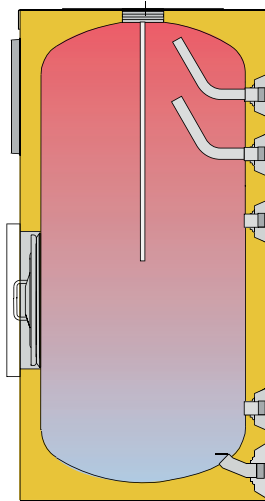

Detail of pre-cut insulation on 800 and 1000 litre tanks allowing access through 800 mm wide doors.

LONG-LASTING PRODUCT: Nickel-chromium-molybdenum **STAINLESS STEEL** DHW storage tank, highly resistant to pitting caused by halogen elements such as chlorine in drinking water. This is the material used to manufacture all of the models in our "GEISER INOX" series.

EASY TO MAINTAIN: With access to tank interior through side and top holes, for inspection and cleaning. Models RB, with a ND400 manhole on the side of the tank.

EASY TO INSTALL: Their dimensions facilitate access to enclosed spaces (even the models with capacities greater than 800 litres), with a detachable system for the insulation on the two opposite sides of the tank, allowing access through 800 mm wide entrances.

ELECTRIC HEATING: Ready for installation with Incoloy, low charge density electric immersion elements or with ceramic heating elements (see ELECTRIC HEATING chapter, page: 38).

MAXIMUM STORAGE CAPACITY: Extra thick, rigid, PU mould-injected insulation that minimizes heat losses of stored DHW (see HEAT INSULATION chapter, page: 41).

Lapesa storage tanks have minimal heat losses and are thus considered to be one of the products with the greatest storage capacity on the market.



FEATURES COMMON TO ALL "GEISER INOX STORAGE" MODELS:

- DHW storage tanks in **AISI 316 L stainless steel**
- Capacities: **200, 300, 500, 800 and 1000 litres**
- Maximum working pressure of DHW storage tank: **8 bar** (10 bar optional)
- Maximum working temperature of DHW storage tank: **90 °C**
- Thermal insulation: **Rigid, mould-injected PU** (CFC/HCFC-free, 0.025 W/m²K)
- Tanks for **VERTICAL** installation on floor.

GEISER INOX "R"

Tanks for **DHW STORAGE**.
DHW production is by means of an external heat exchange system (plate heat exchanger).
They can be fitted with immersion electric elements or ceramic electric elements.
Tanks of more than 800 litre capacities include an insulation system that allows them to pass through 800 mm wide doors.
Finish: RAL 9016 white external lining and RAL 7021 grey cover.

EQUIPMENT: control panel "S" with thermometer.

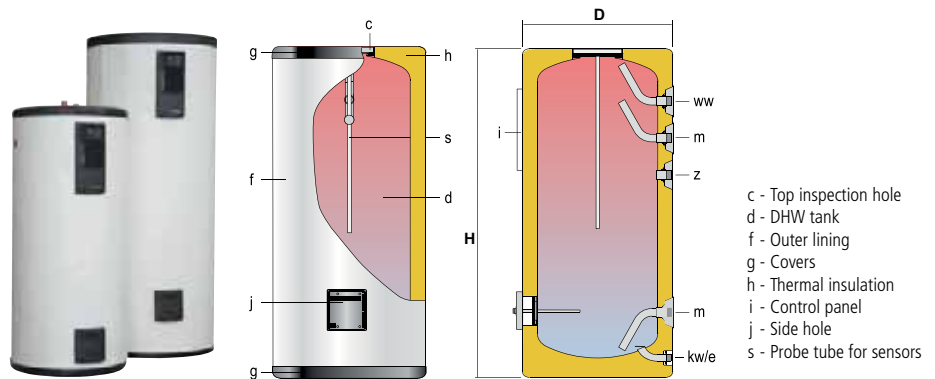

GENERAL CHARACTERISTICS		GX-200-R	GX-300-R	GX-500-R	GX-800-R	GX-1000-R
Total capacity	l.	200	300	500	800	1000
D: external diameter	mm.	620	620	770	950	950
H: overall height	mm.	1205	1685	1690	1840	2250
kw: cold water inlet / drain	" GAS/M	1	1	1	1 1/4"	1 1/4"
ww: DHW outlet	" GAS/M	1 1/4"	1 1/4"	1 1/4"	1 1/2"	1 1/2"
z: recirculation	" GAS/M	1 1/4"	1 1/4"	1 1/4"	1 1/2"	1 1/2"
m: plate exchanger connection	" GAS/M	1 1/4"	1 1/4"	1 1/4"	1 1/2"	1 1/2"
Empty weight (approx.)	Kg	50	64	102	147	170

GEISER INOX "RB"

Tanks for **DHW STORAGE**.
DHW production is by means of an external heat exchange system (plate heat exchanger).
The "RB" models include a ND 400 side manhole.
They can be fitted with immersion electric elements or ceramic electric elements.
The 800 and 1000 litre capacity tanks include an insulation system that allows them to pass through 800 mm wide doors.
Finish: RAL 9016 white external lining and RAL 7021 grey cover.

EQUIPMENT: control panel "S" with thermometer

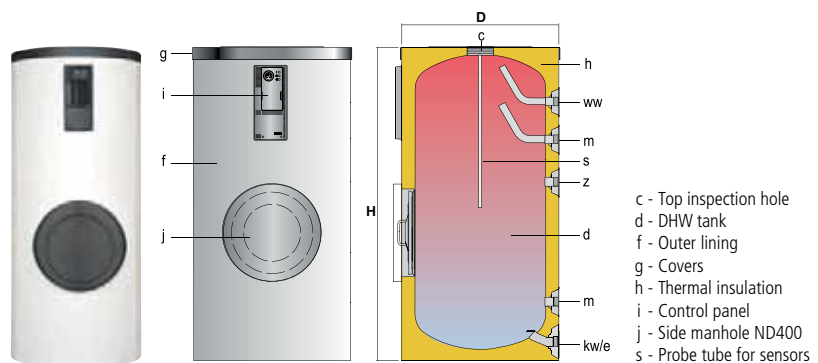

GENERAL CHARACTERISTICS		GX-800-RB	GX-1000-RB
Total capacity	l.	800	1000
D: external diameter	mm.	950	950
H: overall height	mm.	1840	2250
kw: cold water inlet / drain	" GAS/M	1 1/4"	1 1/4"
ww: DHW outlet	" GAS/M	1 1/2"	1 1/2"
z: recirculation	" GAS/M	1 1/2"	1 1/2"
m: plate exchanger connection	" GAS/M	1 1/2"	1 1/2"
Side manhole	mm.	ND400	ND400
Empty weight (approx.)	Kg	178	201

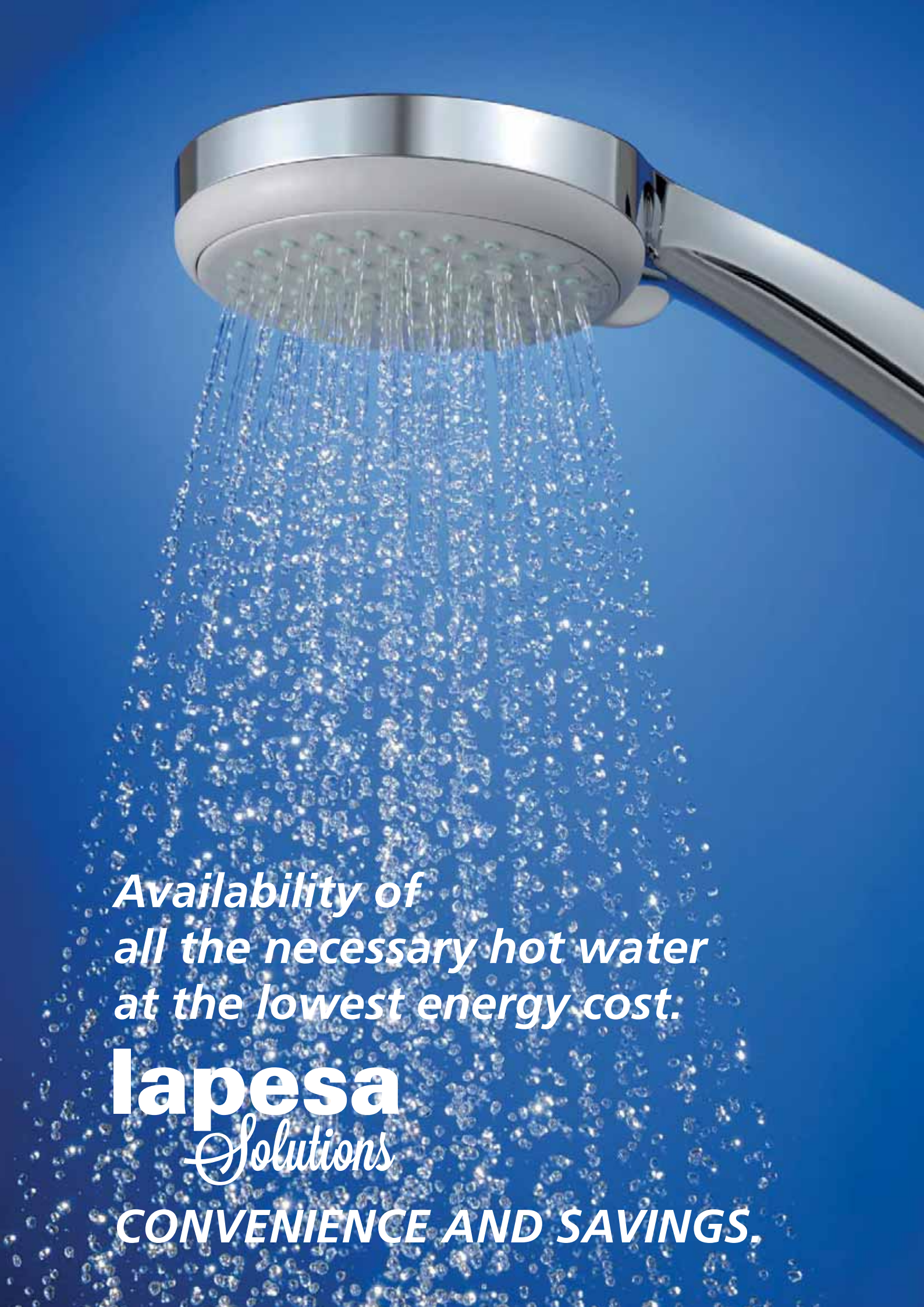

*Availability of
all the necessary hot water
at the lowest energy cost.*

lapesa
Solutions

CONVENIENCE AND SAVINGS.



GEISER INOX - STAINLESS STEEL

Models with COIL, production and efficiency!

Tanks with high-efficiency, internal heat exchange coils for high DWH production demands at peak flow. Their overdimensioned, rigid, mould-injected PU thermal insulation maintains DWH storage temperature for long periods without the need for any additional energy input, providing users with continued savings throughout the life of the storage tank.



STORAGE TANKS WITH COIL:

Tanks with high-efficiency, internal heat exchange coils for high DWH production demands at peak flow.

Models with one or two coils for the production of DWH using one or two energy sources, with the option of adding backup electric heating elements.

Overdimensioned, rigid, mould-injected PU thermal insulation maintains the DWH storage temperature over long periods of time without requiring additional energy input. This means less start-ups and adjustments of external energy sources, which translates into energy savings.

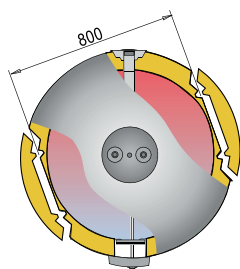
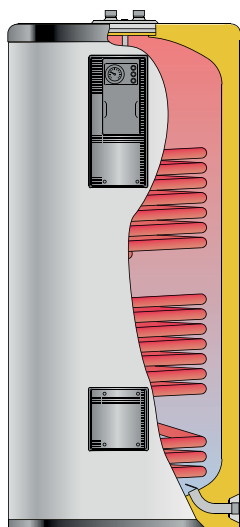

Detail of pre-cut insulation on 800 and 1000 litre tanks to allow access through 800 mm wide doors.

LONG-LASTING PRODUCT: Nickel-chromium-molybdenum **STAINLESS STEEL** DHW storage tank, highly resistant to pitting caused by halogen elements such as chlorine in drinking water. This is the material used to manufacture all of the models in our "GEISER INOX" series.

ANTI-LEGIONELLA DESIGN: The shape of the heat exchange coil is ideal for heating the lowest zone of the storage tank, preventing cold zones and thus the proliferation of bacteria such as Legionella.

EASY TO MAINTAIN: With access to tank interior through side and top holes, for inspection and cleaning. In models with capacities of more than 800 litres there is a ND400 man-hole on the side of the tank.

EASY TO INSTALL: Their dimensions facilitate access to enclosed spaces (even models with capacities greater than 800 litres), with a detachable system for insulation on the two opposite sides of the tank, allowing access through 800 mm wide entrances.

ELECTRIC HEATING: Ready for installation with Incoloy, low charge density electric immersion elements or with ceramic heating elements (see ELECTRIC HEATING chapter, page: 38).

MAXIMUM STORAGE CAPACITY: Extra thick, rigid, PU mould-injected insulation that minimizes heat losses of stored DHW (see DHW PRODUCTION chapter, page: 32).

"Exchange capacity and heat efficiency", for installations with high demands of domestic hot water production, with the best response capacity.



FEATURES COMMON TO ALL "GEISER INOX COIL" MODELS:

- DHW storage tanks in **AISI 316 L stainless steel**
- Capacities: **200, 300, 500, 800 and 1000 litres**
- Maximum working pressure of DHW storage tank: **8 bar** (10 bar optional)
- Maximum working pressure of coil/s: **25 bar**
- Maximum working temperature of DHW storage tank: **90 °C**
- Maximum working temperature of coil/s: **200 °C**
- Thermal insulation: **Rigid, mould-injected PU** (CFC/HCFC-free, 0.025 W/m²K)
- Tanks for **VERTICAL** installation on floor (except TSM models, only **HORIZONTAL**).

GEISER INOX "M1"

Storage tanks with **"ONE COIL"** for the production of DHW using an external energy source (boiler, solar panels, heat pump, etc.).

They can be fitted with immersion electric elements or ceramic electric elements (See ELECTRIC HEATING chapter, page: 38). 800 and 1000 l. tank models, include an insulation system that allows them to pass through 800 mm wide doors.

Tank models M1B include a ND400 side manhole. Finish: RAL 9016 white external lining and RAL 7021 grey cover.

EQUIPMENT:

Side control panel with "ST" thermometer and control thermostat (except GX-150-M1).

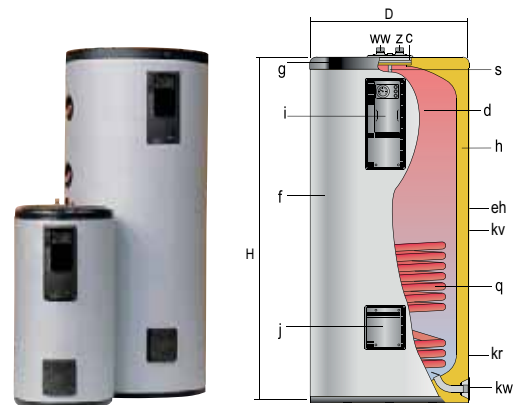

c - Top inspection hole
d - DHW tank
f - Outer lining

g - Cover
h - Thermal insulation
i - Control panel

j - Side hole
q - Heating coil
s - Probe tube for sensors

GENERAL CHARACTERISTICS		GX-150-M1	GX-200-M1	GX-300-M1	GX-500-M1	GX-800-M1	GX-1000-M1	GX-800-M1B	GX-1000-M1B
DHW capacity	l.	150	200	300	500	800	1000	800	1000
D: external diameter	mm.	560	620	620	770	950	950	950	950
H: overall height	mm.	1265	1205	1685	1690	1840	2250	1840	2250
kw: cold water inlet / drain	" GAS/M	1	1	1	1	1 1/4	1 1/4	1 1/4	1 1/4
ww: DHW outlet	" GAS/M	1	1	1	1	1 1/2	1 1/2	1 1/2	1 1/2
z: recirculation	" GAS/M	1	1	1	1	1 1/2	1 1/2	1 1/2	1 1/2
eh: side connection	" GAS/M	-	1 1/2	1 1/2	1 1/2	1 1/2	1 1/2	1 1/2	1 1/2
kv: primary input	" GAS/M	3/4	1	1	1	1	1	1	1
kr: primary return	" GAS/M	3/4	1	1	1	1	1	1	1
Heating coil surface	m ²	0,8	1,1	1,4	1,8	2,8	3,4	2,8	3,4
Empty weight (approx.)	Kg	44	60	85	117	164	189	195	220

NOTE: Models M1B, with side manhole ND400

GEISER INOX "TSC" NEW

Storage tank with **"ONE COIL"** for the production of DHW using an external energy source (boiler, solar panels, heat pump, etc.). All the connections are placed at the top of the tank. Finishing with external lining and top cover in white color RAL 9016.

EQUIPMENT: Thermometer in top cover.

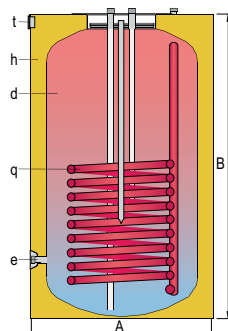
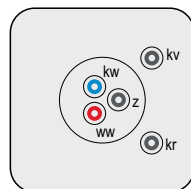

d - DHW tank
e - Drain
f - External lining
h - Thermal insulation
q - Heat exchange coil
t - Thermometer

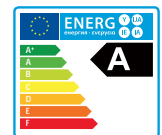

GENERAL CHARACTERISTICS		GX-100-TSC	GX-150-TSC
DHW capacity	l.	102	148
D: external diameter	mm.	510	510
H: overall height	mm.	870	1210
kw: cold water inlet / drain	" GAS/M	3/4	3/4
ww: DHW outlet	" GAS/M	3/4	3/4
z: recirculation DHW	" GAS/M	3/4	3/4
kv: primary input	" GAS/M	3/4	3/4
kr: primary return	" GAS/M	3/4	3/4
e: drain	" GAS/F	1/2	1/2
Heating coil surface	m ²	0,7	1,3
Empty weight (approx.)	Kg	35	47

GEISER INOX "TSM"

Storage tanks with **"ONE COIL"** for the production of DHW using combined external energy sources (boiler, solar panels, heat pump, etc.). Specifically designed for **HORIZONTAL INSTALLATION**, a boiler of up to 700 Kg can be installed on top.

EQUIPMENT: thermometer and DHW control thermostat on front cover.

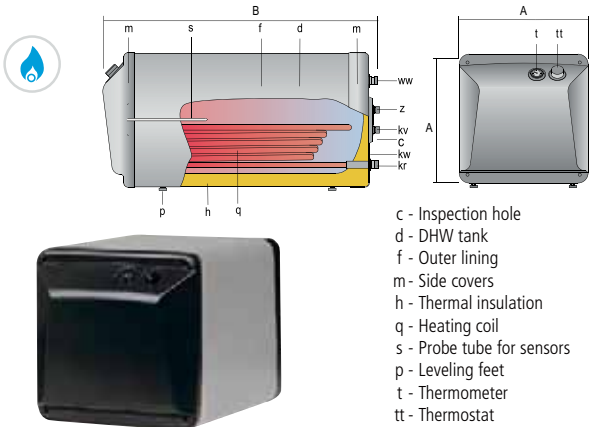

GENERAL CHARACTERISTICS	GX-150-TSM	GX-200-TSM	
DHW capacity	l.	150	200
A: Height / width	mm.	630	630
B: Length	mm.	1000	1255
kw: cold water inlet / drain	" GAS/M	3/4	3/4
ww: DHW outlet	" GAS/M	3/4	3/4
z: recirculation	" GAS/M	3/4	3/4
kv: primary input	" GAS/M	3/4	3/4
kr: primary return	" GAS/M	3/4	3/4
Heating coil surface	m ²	0,7	0,9
Empty weight (approx.)	Kg	51	70

GEISER INOX "M2"

Storage tanks with **"TWO COILS"** for the production of DHW using combined external energy sources (boiler, solar panels, heat pump, etc.).

They can be fitted with immersion electric elements or ceramic electric elements (See ELECTRIC HEATING chapter, page: 38).

800 and 1000 l. tank models, include an insulation system that allows them to pass through 800 mm wide doors.

Tank models M2B include a ND400 side manhole.

Finish: RAL 9016 white external lining and RAL 7021 grey cover.

EQUIPMENT:

Side control panel with "ST" thermometer and control thermostat.

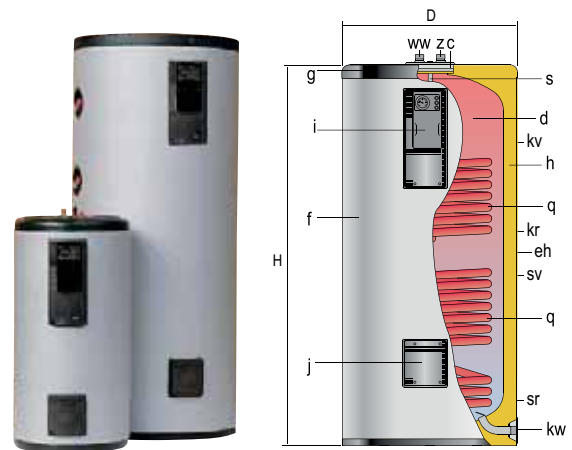

c - Top inspection hole
d - DHW tank
f - Outer lining
g - Cover
h - Thermal insulation

i - Control panel
j - Side hole
q - Heating coil
s - Probe tube for sensors



GENERAL CHARACTERISTICS		GX-300-M2	GX-400-M2	GX-500-M2	GX-800-M2	GX-1000-M2	GX-800-M2B	GX-1000-M2B
DHW capacity	l.	300	400	500	800	1000	800	1000
D: external diameter	mm.	620	770	770	950	950	950	950
H: overall height	mm.	1685	1525	1690	1840	2250	1840	2250
kw: cold water inlet / drain	" GAS/M	1	1	1	1 1/4	1 1/4	1 1/4	1 1/4
ww: DHW outlet	" GAS/M	1	1	1	1 1/2	1 1/2	1 1/2	1 1/2
z: recirculation	" GAS/M	1	1	1	1 1/2	1 1/2	1 1/2	1 1/2
eh: side connection	" GAS/M	1 1/2	1 1/2	1 1/2	1 1/2	1 1/2	1 1/2	1 1/2
kv, kr: upper coil connections	" GAS/M	1	1	1	1	1	1	1
sv, sr: lower coil connections	" GAS/M	1	1	1	1	1	1	1
Upper coil heating surface	m ²	1,1	0,9	1,2	1,3	1,3	1,3	1,3
Lower coil heating surface	m ²	1,4	1,8	1,8	2,8	3,4	2,8	3,4
Empty weight (approx.)	Kg	93	120	126	175	200	206	231

NOTE: M2B models, with side manhole ND400

GEISER INOX "HL"

Storage tanks with **HIGH PERFORMANCE COIL**, with high thermal exchange surface, for the production of DHW using combined external energy sources (boiler, solar panels, heat pump, etc.).

They can be fitted with immersion electric elements (See ELECTRIC HEATING chapter, page: 38).

Tank models of 800 L or higher, include a ND400 side manhole and an insulation system that allows them to pass through 800 mm wide doors.

Finish: RAL 9016 white external lining and RAL 7021 grey cover.

EQUIPMENT:

Models "HLB" with side manhole ND400.

Side control panel with thermometer.

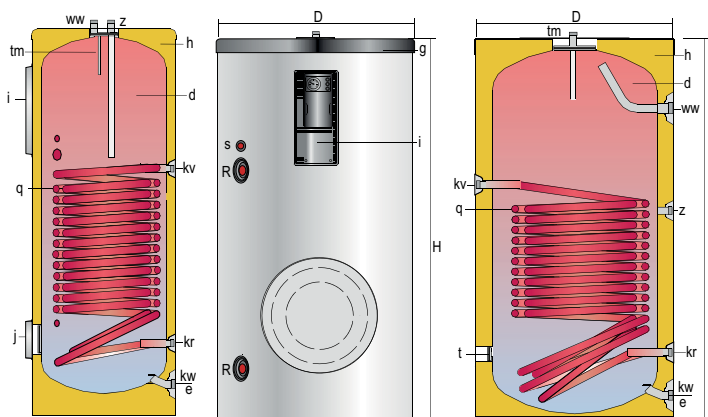

- c - Top inspection hole
- d - DHW tank
- f - Outer lining
- g - Cover
- h - Thermal insulation
- i - Control panel
- j - Side hole
- q - Heating coil
- s - Probe tube for sensors

GENERAL CHARACTERISTICS		GX-200-HL	GX-300-HL	GX-500-HL	GX-800-HLB	GX-1000-HLB
DHW capacity	l.	200	300	500	800	1000
D: external diameter	mm.	620	620	770	950	950
H: overall height	mm.	1205	1685	1690	1840	2250
kw: cold water inlet / drain	" GAS/M	1	1	1	1 1/4	1 1/4
ww: DHW outlet	" GAS/M	1	1	1	1 1/2	1 1/2
z: recirculation	" GAS/M	1	1	1	1 1/2	1 1/2
eh: side connection	" GAS/M	2	2	2	2	2
kv: primary input	" GAS/M	1 1/4	1 1/4	1 1/4	1 1/4	1 1/4
kr: primary return	" GAS/M	1 1/4	1 1/4	1 1/4	1 1/4	1 1/4
Heating coil surface	m ²	2,4	3,1	4,8	5,7	6,4
Empty weight (approx.)	Kg	63	83	120	221	258

NOTE: HLB models, with side manhole ND400

LONG-LASTING PRODUCT:

Nickel-chromium-molybdenum STAINLESS STEEL DHW storage tank, highly resistant to pitting caused by halogen elements such as chlorine in drinking water. This is the material used to manufacture all of the models in our "GEISER INOX" series.

HYGIENIC MATERIAL:

Easy to clean, allows the use of strong washing and disinfecting methods (e.g. anti-legionella treatment). In DHW tanks made of stainless steel there is no accumulation of residues from sacrificial anodes because the tanks do not require cathodic protection in normal working conditions.

FOOD GRADE:

Stainless steel is a non-toxic material that is commonly used in the food industry. In hygiene tests it is on a par with glass and porcelain and is thus considered ideal for use in the manufacture of tanks intended for the production and storage of domestic hot water.

ANTI LEGIONELLA DESIGN:

The surround heating of DHW produces a uniform water storage temperature throughout the whole of the tank, avoiding cold zones and allowing to use the full capacity of the tank. In models equipped with heat exchange coil, the stored water is heated from the lowest zone of the tank, therefore hot water can be stored in the complete tank volume.

EFFECTIVE SAVING:

Rigid, mould-injected PU thermal insulation maintains the DHW storage temperature over long periods of time, therefore reducing heat losses. Tanks adapted to requirements of ErP Directive.

EXAMPLES OF INSTALLATION "GEISER INOX"

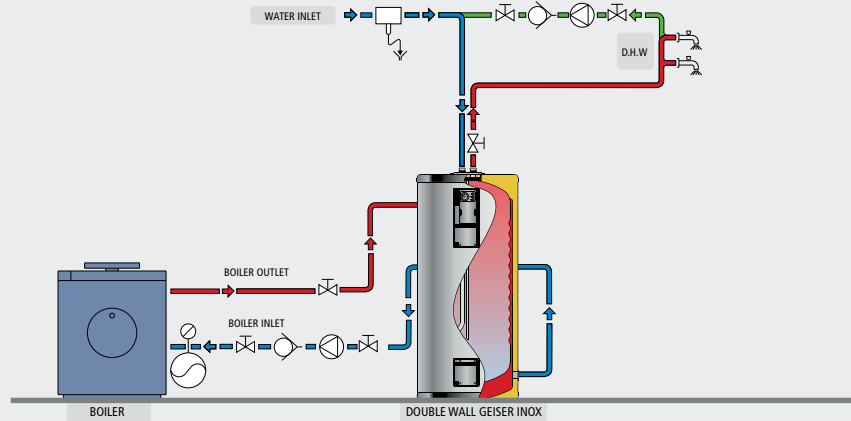

EXAMPLE OF INSTALLATION: DOUBLE WALL GEISER INOX

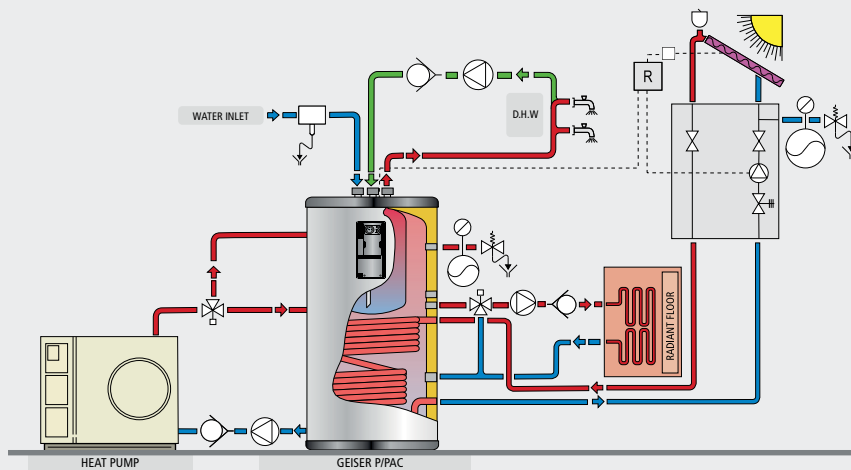

EXAMPLE OF INSTALLATION: GEISER INOX P/PAC

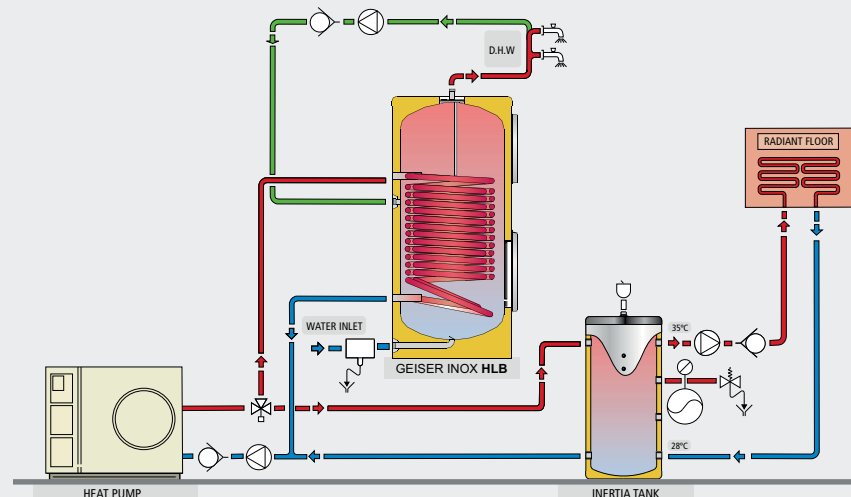

EXAMPLE OF INSTALLATION: GEISER INOX HL/HLB

LEGEND

- Sanitary safety group
- Non-return valve
- Circulator
- Deaerator
- Drain
- Three-way valve
- Expansion vessel
- Safety valve

PRIMARY INPUT TEMPERATURE °C		55 °C		70 °C		80 °C		90 °C			
tank model	primary pump flow (m³/h)	KW	DHW (l/h)	KW	DHW (l/h)	KW	DHW (l/h)	KW	DHW (l/h)		
GEISER INOX - DOUBLE WALL [Continuous flow DHW production (liters/hour) 10°C - 45°C]	GX6 S/D/DEC 90	2	5	123	11	271	14	344	18	443	
		3	6	148	12	295	15	369	20	492	
		5	7	172	13	320	17	418	22	541	
	GX6 S/D/DEC 130	2	9	221	19	468	25	615	32	787	
		3	10	246	20	492	27	664	34	837	
		5	11	271	22	541	30	738	37	910	
	GX6 S/D/DEC 190	2	8	197	18	443	25	615	32	787	
		3	9	221	20	492	27	664	35	861	
		5	11	271	22	541	30	738	39	960	
	GX6 S/D/DEC 260	2	11	271	25	615	33	812	44	1083	
		3	12	295	27	664	36	886	48	1181	
		5	13	320	29	714	41	1009	53	1304	
	GX6 S/D/DEC 400	2	17	418	33	812	45	1107	55	1353	
		4	19	468	38	935	53	1304	66	1624	
		6	20	492	41	1009	57	1403	72	1772	
	GX6 S/D/DEC 600	2	20	492	39	960	52	1280	66	1624	
		4	22	541	45	1107	60	1476	78	1919	
		6	24	591	48	1181	65	1599	85	2092	
	GX6 TS180	2	9	221	17	418	23	566	29	714	
		3	10	246	18	443	25	615	32	787	
		5	11	271	19	468	27	664	35	861	
	GX6 TS240	2	10	246	21	517	28	689	36	886	
		3	11	271	22	541	31	763	39	960	
		5	13	320	24	591	34	837	42	1033	
	GEISER INOX - COIL [Continuous flow DHW production (liters/hour) 10°C - 45°C]	GX-150-M1	2	11	271	21	517	28	689	34	837
			3	12	295	23	566	31	763	38	935
			5	13	320	26	640	35	861	43	1058
GX-200-M1		2	15	369	28	689	37	910	47	1157	
		3	16	394	32	787	43	1058	53	1304	
		5	18	443	36	886	49	1206	61	1501	
GX-300-M1/M2* *lower coil		2	15	369	33	812	45	1107	56	1378	
		4	18	443	42	1033	56	1378	69	1698	
		6	19	468	47	1157	62	1526	77	1895	
GX-500-M1/M2* * lower coil		2	20	492	40	984	53	1304	66	1624	
		4	23	566	51	1255	67	1649	83	2042	
		6	25	615	58	1427	76	1870	93	2288	
GX-800-M1/M2* * lower coil		3	33	812	62	1526	79	1944	98	2411	
		5	39	960	72	1772	94	2313	116	2854	
		8	44	1083	82	2018	108	2658	132	3248	
GX-1000-M1/M2* * lower coil		3	40	984	77	1895	101	2485	127	3125	
		5	47	1157	94	2313	124	3051	155	3814	
		8	54	1329	110	2707	145	3568	181	4454	
GX-300-M2** ** upper coil		2	15	369	27	664	36	886	45	1107	
		4	17	418	33	812	44	1083	55	1353	
		6	18	443	37	910	49	1206	61	1501	
GX-500-M2** ** upper coil		2	15	369	31	763	41	1009	50	1230	
		4	18	443	38	935	50	1230	61	1501	
		6	20	492	42	1033	56	1378	68	1673	
GX-800-M2** ** upper coil		2	15	369	31	763	41	1009	50	1230	
		4	18	443	38	935	50	1230	61	1501	
		6	20	492	42	1033	56	1378	68	1673	
GX-1000-M2** ** upper coil		2	15	369	31	763	41	1009	50	1230	
		4	18	443	38	935	50	1230	61	1501	
		6	20	492	42	1033	56	1378	68	1673	
GX-150-TSM	2	9	221	19	468	25	615	32	787		
	4	10	246	22	541	30	738	37	910		
	6	11	271	24	591	32	787	41	1009		
GX-200-TSM	2	11	271	24	591	31	763	39	960		
	4	14	344	30	738	38	935	47	1157		
	6	15	369	33	812	42	1033	52	1280		

NOTE: for further information, consult our technical product catalog.

PRIMARY INPUT TEMPERATURE °C		70 °C		80 °C		90 °C		
tank model	primary pump flow (m³/h)	KW	DHW (l/h)	KW	DHW (l/h)	KW	DHW (l/h)	
GEISER INOX - DOUBLE WALL [Continuous flow DHW production (liters/hour) 10°C - 60°C]	GX6 S/D/DEC 90	2	7	121	11	189	16	276
		3	8	138	12	207	17	293
		5	9	155	13	224	18	310
	GX6 S/D/DEC 130	2	13	224	20	344	27	465
		3	14	241	21	362	29	500
		5	16	276	23	396	32	551
	GX6 S/D/DEC 190	2	13	224	20	344	27	465
		3	15	258	22	379	29	500
		5	16	276	24	413	32	551
GX6 S/D/DEC 260	2	18	310	27	465	35	603	
	3	20	344	29	500	39	672	
	5	22	379	32	551	43	741	
GX6 S/D/DEC 400	2	23	396	36	620	47	810	
	4	27	465	42	723	55	947	
	6	29	500	46	792	60	1033	
GX6 S/D/DEC 600	2	27	465	42	723	57	982	
	4	32	551	48	827	66	1137	
	6	34	586	52	896	72	1240	
GX6 TS180	2	12	207	18	310	25	431	
	3	13	224	20	344	27	465	
	5	14	241	21	362	29	500	
GX6 TS240	2	15	258	23	396	31	534	
	3	16	276	25	431	33	568	
	5	17	293	27	465	35	603	
GEISER INOX - COIL [Continuous flow DHW production (liters/hour) 10°C - 60°C]	GX-150-M1	2	15	258	23	396	29	500
		3	17	293	25	431	32	551
		5	18	310	28	482	36	620
	GX-200-M1	2	21	362	31	534	40	689
		3	24	413	35	603	45	775
		5	28	482	40	689	52	896
	GX-300-M1/M2* * lower coil	2	24	413	36	620	47	810
		4	30	517	44	758	58	999
		6	33	568	49	844	65	1120
	GX-500-M1/M2* * lower coil	2	30	517	44	758	57	982
		4	37	637	55	947	70	1206
		6	40	689	61	1051	78	1344
	GX-800-M1/M2* * lower coil	3	44	758	63	1085	83	1430
		5	51	878	74	1275	98	1688
		8	58	999	83	1430	112	1929
	GX-1000-M1/M2* * lower coil	3	57	982	83	1430	109	1878
		5	68	1171	99	1705	132	2274
		8	78	1344	115	1981	153	2635
	GX-300-M2** ** upper coil	2	18	310	30	517	38	655
		4	22	379	36	620	46	792
		6	24	413	40	689	51	878
	GX-500-M2** ** upper coil	2	21	362	34	586	44	758
		4	26	448	41	706	53	913
		6	29	500	45	775	59	1016
	GX-800-M2** ** upper coil	2	21	362	34	586	44	758
		4	26	448	41	706	53	913
		6	29	500	45	775	59	1016
GX-1000-M2** ** upper coil	2	21	362	34	586	44	758	
	4	26	448	41	706	53	913	
	6	29	500	45	775	59	1016	
GX-150-TSM	2	13	224	20	344	27	465	
	4	16	276	24	413	32	551	
	6	17	293	26	448	34	586	
GX-200-TSM	2	17	293	25	431	33	568	
	4	21	362	30	517	40	689	
	6	24	413	34	586	44	758	

PRIMARY INPUT TEMPERATURE °C		55 °C		70 °C		80 °C		90 °C	
tank model	primary pump flow (m³/h)	KW	DHW (l/h)	KW	DHW (l/h)	KW	DHW (l/h)	KW	DHW (l/h)
GX6 DE 140	2	8	205	18	450	24	625	32	790
	4	10	250	21	500	28	700	36	880
	6	12	300	23	555	31	750	39	950
GX6 DE 180	2	9	210	19	460	25	630	33	795
	4	11	255	21	510	29	710	36	890
	6	13	305	23	560	31	750	40	960
GX6 DE 215	2	11	300	26	620	34	820	45	1105
	4	13	320	30	720	41	995	53	1300
	6	15	350	32	795	44	1090	56	1390
GX6 DE 260	3	16	400	31	790	44	1070	54	1305
	5	18	420	35	870	49	1180	59	1405
	8	19	440	38	925	51	1270	65	1600
GX6 DE 400	3	19	450	36	900	50	1210	61	1510
	5	20	495	41	1010	55	1350	66	1670
	8	21	510	44	1050	60	1505	75	1860
GX6 DE 600	3	21	550	41	1005	56	1370	71	1800
	5	22	580	45	1120	61	1510	81	2000
	8	24	600	50	1210	68	1660	90	2200
GX6 DE 1000	2	25	625	45	1100	65	1600	95	2330
	4	37	900	58	1400	85	2075	118	2900
	6	40	1000	65	1600	93	2300	132	3250
GX6 PAC/P 300	2	8	200	16	400	24	600	30	740
	4	10	245	19	455	26	650	35	860
	6	11	265	21	500	30	725	37	915
GX6 PAC/P 400	2	8	200	17	425	25	610	33	805
	4	10	245	20	485	27	690	35	860
	6	11	265	22	545	32	775	40	980
GX6 PAC/P 600	2	9	240	22	545	29	735	40	985
	4	11	275	26	645	34	850	46	1150
	6	13	320	28	700	36	915	49	1210
GX-200-HL	2	25	614	47	1145	61	1511	78	1909
	4	32	776	60	1484	81	1987	100	2473
	6	35	872	69	1688	92	2272	114	2810
GX-300-HL	2	30	749	58	1432	75	1850	95	2348
	4	40	986	76	1861	98	2416	126	3095
	6	46	1127	86	2118	112	2755	144	3543
GX-500-HL	2	39	969	73	1786	94	2317	115	2829
	4	53	1314	93	2293	124	3040	154	3795
	6	62	1519	105	2595	141	3470	178	4371
GX-800-HLB	3	56	1383	101	2479	125	3080	152	3728
	5	67	1660	125	3076	154	3791	182	4478
	8	78	1919	148	3635	181	4457	211	5181
GX-1000-HLB	3	58	1428	106	2603	131	3212	158	3891
	5	69	1704	129	3187	159	3924	192	4722
	8	80	1961	152	3732	187	4590	224	5501

GEISER INOX - DOUBLE WALL
 [Continuous flow DHW production (liters/hour) 10°C - 45°C]

GGEISER INOX - COIL
 [Continuous flow DHW production (l/h) 10°C - 45°C]



PRIMARY INPUT TEMPERATURE °C		70 °C		80 °C		90 °C	
tank model	primary pump flow (m³/h)	KW	DHW (l/h)	KW	DHW (l/h)	KW	DHW (l/h)
GX6 DE 140	2	12	205	20	345	26	455
	4	15	255	22	375	31	525
	6	16	275	24	405	32	555
GX6 DE 180	2	13	225	21	355	26	460
	4	16	260	22	390	31	530
	6	17	275	24	415	33	555
GX6 DE 215	2	19	315	30	520	37	645
	4	22	385	34	585	44	755
	6	24	410	36	605	47	810
GX6 DE 260	3	22	345	34	600	45	760
	5	25	430	37	650	50	855
	8	26	455	40	700	55	950
GX6 DE 400	3	25	440	40	695	51	890
	5	28	490	44	750	57	1000
	8	30	505	47	805	61	1055
GX6 DE 600	3	29	500	45	780	61	1070
	5	32	550	50	860	70	1200
	8	35	600	55	910	76	1300
GX6 DE 1000	2	32	580	55	950	82	1400
	4	41	700	68	1180	105	1740
	6	46	800	75	1300	112	1910
GX6 PAC/P 300	2	11	200	18	310	25	425
	4	14	225	21	360	30	515
	6	15	250	23	385	32	550
GX6 PAC/P 400	2	13	230	21	360	26	460
	4	15	255	24	395	31	525
	6	18	305	25	425	34	560
GX6 PAC/P 600	2	14	250	24	400	31	530
	4	18	310	28	480	37	635
	6	19	320	30	520	40	690
GX-200-HL	2	34	585	50	864	67	1155
	4	43	745	81	1265	86	1478
	6	49	842	74	1279	97	1671
GX-300-HL	2	43	747	62	1072	83	1434
	4	55	945	80	1377	108	1858
	6	62	1065	90	1556	123	2114
GX-500-HL	2	55	946	80	1373	101	1748
	4	68	1175	101	1747	133	2296
	6	76	1312	114	1972	152	2625
GX-800-HLB	3	76	1303	105	1801	133	2292
	5	92	1586	126	2175	157	2707
	8	107	1844	147	2532	180	3100
GX-1000-HLB	3	80	1385	109	1882	139	2392
	5	95	1644	131	2260	166	2855
	8	110	1896	151	2609	191	3297

GEISER INOX - DOUBLE WALL
 [Continuous flow DHW production (liters/hour) 10°C - 60°C]

GGEISER INOX - COIL
 [Continuous flow DHW production (l/h) 10°C - 60°C]

GEISER INOX - models **DOUBLE WALL - S/D/DE/DEC/P/PAC** - (DHW production - **peak flow** -)

		GX6 S/D/DEC 90	GX6 S/D/DEC 130	GX6 S/D/DEC 190	GX6 S/D/DEC 260	GX6 S/D/DEC 400	GX6 S/D/DEC 600
Peak flow 40°C	L/10'	120	203	315	380	575	900
Peak flow 45°C	L/10'	102	175	270	325	490	770
Peak flow 60°C	L/10'	72	122	190	225	344	539
Peak flow 40°C	L/60'	590	1000	1132	1545	2135	2755
Peak flow 45°C	L/60'	495	840	954	1290	1790	2310
Peak flow 60°C	L/60'	295	515	590	755	1075	1400
Continuous flow 40°C	Ltrs/h	565	960	980	1400	1875	2225
Continuous flow 45°C	Ltrs/h	470	800	820	1160	1560	1850
Continuous flow 60°C	Ltrs/h	265	470	480	635	875	1040
Heating time (from 10 to 75°C)	Min	28	31	45	47	50	56
Primary flow	m³/h	5	5	5	6	6	6

Primary input temperature 85°C

		GX6 DE140	GX6 DE180	GX6 DE215	GX6 DE260	GX6 DE400	GX6 DE600
Peak flow 40°C	L/10'	203	315	475	530	575	900
Peak flow 45°C	L/10'	175	270	415	440	490	770
Peak flow 60°C	L/10'	122	190	250	265	344	539
Peak flow 40°C	L/60'	935	1190	1675	1875	2175	2790
Peak flow 45°C	L/60'	785	1000	1415	1565	1820	2345
Peak flow 60°C	L/60'	465	605	795	925	1100	1435
Continuous flow 40°C	Ltrs/h	880	1050	1440	1620	1920	2270
Continuous flow 45°C	Ltrs/h	735	880	1200	1350	1600	1890
Continuous flow 60°C	Ltrs/h	415	500	653	790	905	1075
Heating time (from 10 to 75°C)	Min	31	41	37	37	50	56
Primary flow	m³/h	2,6	3,5	4,2	5,5	6,4	7,2

Primary input temperature 85°C

		GX6 P300	GX6 P400	GX6 P600	GX6 P800	GX6 P1000
Peak flow 40°C	L/10'	251	320	465	433	540
Peak flow 45°C	L/10'	215	275	400	370	465
Peak flow 60°C	L/10'	150	190	280	260	325
Peak flow 40°C	L/60'	965	1080	1360	1495	1875
Peak flow 45°C	L/60'	815	910	1150	1250	1570
Peak flow 60°C	L/60'	500	555	710	785	970
Continuous flow 40°C	Ltrs/h	860	915	1075	1275	1600
Continuous flow 45°C	Ltrs/h	720	760	900	1060	1325
Continuous flow 60°C	Ltrs/h	420	440	520	630	775
Heating time (from 10 to 75°C)	Min	40	48	55	47	48
Primary flow	m³/h	3	3	3	5	5

Primary input temperature 85°C

		GX6 PAC300	GX6 PAC400	GX6 PAC600	GX6 PAC800	GX6 PAC1000
Peak flow 40°C	L/10'	250	315	600	433	540
Peak flow 45°C	L/10'	215	270	515	370	465
Peak flow 60°C	L/10'	150	190	360	260	325
Peak flow 40°C	L/60'	1050	1165	1650	1495	1875
Peak flow 45°C	L/60'	880	975	1390	1250	1570
Peak flow 60°C	L/60'	525	585	870	785	970
Continuous flow 40°C	Ltrs/h	960	1020	1260	1275	1600
Continuous flow 45°C	Ltrs/h	800	850	1050	1060	1325
Continuous flow 60°C	Ltrs/h	450	475	610	630	775
Heating time (from 10 to 75°C)	Min	40	48	54	47	48
Primary flow	m³/h	5	5	5	5	5

Primary input temperature 85°C

GEISER INOX, DHW production - peak flow -		DOUBLE WALL TS models		COIL TSM models	
		GX6 TS180	GX6 TS240	GX-150-TSM	GX-200-TSM
Peak flow 40°C	L/10'	238	303	320	410
Peak flow 45°C	L/10'	204	260	275	350
Peak flow 60°C	L/10'	143	182	195	245
Peak flow 40°C	L/60'	994	1238	1185	1510
Peak flow 45°C	L/60'	834	1039	995	1270
Peak flow 60°C	L/60'	505	629	610	775
Continuous flow 40°C	Ltrs/h	908	1122	1040	1325
Continuous flow 45°C	Ltrs/h	757	935	865	1105
Continuous flow 60°C	Ltrs/h	435	537	500	635
Heating time (from 10 to 75°C)	Min	44	46	37	42
Primary flow	m³/h	5	6	5	6

Primary input temperature 85°C

GEISER INOX - models with **COIL - M1/M2/HL** - (DHW production - **peak flow** -)

		GX-150 M1	GX-200 M1	GX-300 M1	GX-400 M1	GX-500 M1	GX-800 M1	GX-1000 M1	GX-800 M1B	GX-1000 M1B
Peak flow 40°C	L/10'	315	425	600	823	1007	1690	1995	1692	1995
Peak flow 45°C	L/10'	270	364	515	705	863	1450	1710	1450	1710
Peak flow 60°C	L/10'	190	255	360	494	604	1015	1195	1015	1197
Peak flow 40°C	L/60'	1265	1840	2310	2865	3050	4610	5950	4610	5950
Peak flow 45°C	L/60'	1060	1530	1910	2410	2570	3860	5000	3860	5000
Peak flow 60°C	L/60'	645	930	1170	1475	1580	2370	3110	2370	3110
Continuous flow 40°C	Ltrs/h	1140	1700	2050	2450	2450	3500	4750	3500	4750
Continuous flow 45°C	Ltrs/h	950	1400	1675	2050	2050	2900	3950	2900	3950
Continuous flow 60°C	Ltrs/h	550	810	975	1175	1175	1625	2300	1625	2300
Heating time (from 10 to 75°C)	Min	35	37	45	40	50	52	58	52	58
Primary flow	m³/h	5	6	6	6	6	8	8	8	8

Primary input temperature 85°C

LOWER COIL		GX-300 M2	GX-400 M2	GX-500 M2	GX-800 M2	GX-1000 M2	GX-800 M2B	GX-1000 M2B
Peak flow 40°C	L/10'	600	823	1007	1692	1995	1692	1995
Peak flow 45°C	L/10'	515	705	863	1450	1710	1450	1710
Peak flow 60°C	L/10'	360	494	604	1015	1197	1015	1197
Peak flow 40°C	L/60'	2310	2865	3050	4610	5950	4610	5950
Peak flow 45°C	L/60'	1910	2410	2570	3860	5000	3860	5000
Peak flow 60°C	L/60'	1170	1475	1580	2370	3110	2370	3110
Continuous flow 40°C	Ltrs/h	2050	2450	2450	3500	4750	3500	4750
Continuous flow 45°C	Ltrs/h	1675	2050	2050	2900	3950	2900	3950
Continuous flow 60°C	Ltrs/h	975	1175	1175	1625	2300	1625	2300
Heating time (from 10 to 75°C)	Min	45	40	50	52	58	52	58
Primary flow	m³/h	6	6	6	8	8	8	8

Primary input temperature 85°C

		GX-200 HL	GX-300 HL	GX-500 HL	GX-800 HLB	GX-1000 HLB
Peak flow 40°C	L/10'	580	800	1200	1770	2115
Peak flow 45°C	L/10'	490	675	1015	1505	1800
Peak flow 60°C	L/10'	320	455	690	1035	1245
Peak flow 40°C	L/60'	3285	4135	5310	6780	7315
Peak flow 45°C	L/60'	2695	3395	4375	5590	6040
Peak flow 60°C	L/60'	1625	2079	2690	3455	3760
Continuous flow 40°C	Ltrs/h	3115	3850	4790	5890	6170
Continuous flow 45°C	Ltrs/h	2540	3150	3920	4820	5045
Continuous flow 60°C	Ltrs/h	1475	1840	2300	2820	2955
Heating time (from 10 to 75°C)	Min	26	32	39	45	54
Primary flow	m³/h	6	6	6	8	8

Primary input temperature 85°C

GEISER INOX "DOUBLE WALL" (models D/DEC)

AISI 321 flanged electric heating elements, specific for primary heating circuit

electric element model	KW	V	installed as standard on tank models	optional application to tank models
RC-15/15-D	1,5	230	GX6 DEC90	GX6 D/DEC-90/130
RC-15/15-I	1,5	230		GX6 D/DEC-90/130
RC-16/22-D	2,2	230	GX6 DEC130	GX6 D/DEC-90/130
RC-16/22-I	2,2	230		GX6 D/DEC-90/130
RC-17/22-D	2,2	230	GX6 DEC190	GX6 D/DEC-190/600
RC-17/22-I	2,2	230		GX6 D/DEC-190/600
RC-18/25-D	2,5	230	GX6 DEC260/400	GX6 D/DEC-190/600
RC-18/25-I	2,5	230		GX6 D/DEC-190/600
RC-08/45-D	4,5	230	GX6 DEC600	GX6 D/DEC-600
RC-50D	5,0	400		GX6 D/DEC-600
RC-75D	7,5	400		GX6 D/DEC-600

GEISER INOX "DOUBLE WALL" (models DE/P/PAC)

Threaded immersion electric heating elements, specific for primary heating circuit.

electric element model	KW	V	length L*	optional application to tank models
RI 4/2-22	2,2	3-230 / 3-400	260	GX6 DE-140/1000, GX6 P/PAC-300/1000
RI 4/2-54	5,4	3-230 / 3-400	345	GX6 DE-140/1000, GX6 P/PAC-300/1000
RI 4/2-72	7,2	3-230 / 3-400	445	GX6 DE-215/1000, GX6 P/PAC-400/1000
RI 4/2-90	9,0	3-230 / 3-400	505	GX6 DE-400/1000, GX6 P/PAC-400/1000
RI 4/2-120	12,0	3-230 / 3-400	680	GX6 DE 600/1000, GX6 P/PAC-600/1000

GEISER INOX "SINGLE WALL" (STORAGE and COIL tank models)

Backup heating, Incoloy immersion electric heating elements.

electric element model*	KW	V	length L*	optional application to tank models
RB-25	2,5	230/400	310	GX-200...1000-R/M1/M2
RB-50	5	230/400	310	GX-200...1000-R - GX-400...1000-M1/M2
RB-75	7,5	230/400	440	GX-500...1000-R - GX-800...1000-M1/M2
RB-100	10,0	230/400	580	GX-800...1000-R

(*) In GEISER models with Correx-up cathodic protection, please consult options to install electric kit "RB-25/50/75/100" in lateral inspection opening

Ceramic electric heating elements, sheathed in stainless steel plate. Stainless steel plate set + ceramic electric element, for side hole mounting.

electric element model	KW	V	length L*	optional application to tank models
RCER-12	1,2	230/400	300	GX-...-R/M1/M2
RCER-15	1,5	230/400	300	GX-...-R/M1/M2
RCER-20	2,0	230/400	400	GX-...-R/M1/M2
RCER-24	2,4	230/400	400	GX-...-R/M1/M2

Backup heating, Incoloy immersion electric heating elements.

electric element model	KW	V	IP	thread	length L*	optional application to tank models
RA2/2-15	1,5	230	40	1" M	650	GX6 PAC**
RA3/2-25	2,5	230	40	1 1/2" M	540	GX-200...1000-M1/M2
RA3/2-25T(*)	2,5	230	65	1 1/2" M	350	GX-200...1000-M1/M2
RA3/2-50	5,0	230/400	40	1 1/2" M	690	GX-400...1000-M1/M2

(*) Model RA 3/2-25T, incorporates regulation and safety thermostat in an IP65 head.

(**) For PAC models, on special upper plate.

GEISER INOX "SINGLE WALL" (800 and 1000 litres STORAGE models "RB", with side manhole ND400)

Incoloy threaded immersion electric heating elements for ND400 side manhole on models GX-800/1000-RB. ND400 stainless steel plate set with 2" F bushings + selected type and number of electric elements. Number of electric elements per plate on side manhole ND400: 3, 4, 5, 6, 7 or 8 units.

electric element model	KW	V	IP	thread	length L*	optional application to tank models
RA4/2-60	6,0	230/400	40	2"	797	GX-800/1000-RB
RA4/2-120D	12,0	230/400	40	2"	680	GX-800/1000-RB

Ceramic electric heating elements sheathed in stainless steel plate for ND400 side manhole on models GX-800/1000-RB. Stainless steel plate set with sleeves for ceramic electric elements + selected number of electric elements. Number of electric elements per plate on side manhole ND400: 3, 4, 5, 6, 7 or 8 units.

electric element model	KW	V	length L*	optional application to tank models
RCER-45	4,5	230/400	800	GX-800/1000-RB



"RC" HEATING ELEMENT: Flanged heating element for GEISER INOX "DOUBLE WALL". Models D/DEC.

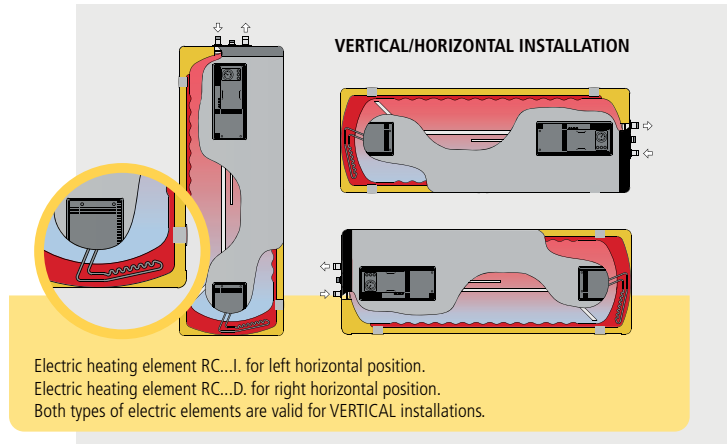

"RI" HEATING ELEMENTS: Threaded immersion heating elements for primary heating circuit, for GEISER INOX "DOUBLE WALL". Models P/DE/PAC.

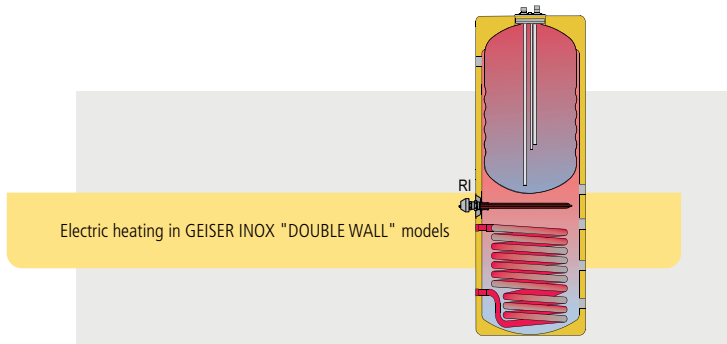

"RB" HEATING ELEMENT: Flanged heating element for GEISER INOX "SINGLE WALL", STORAGE AND COIL models.

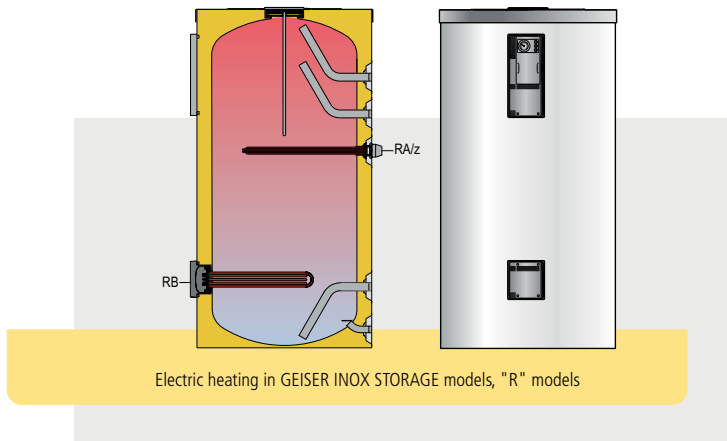

"RCER" HEATING ELEMENT: Flanged, sheathed ceramic heating element for GEISER INOX "SINGLE WALL", STORAGE AND COIL models.



"RA" HEATING ELEMENT: Threaded heating elements for backup heating in GEISER INOX "SINGLE WALL", STORAGE and COIL models

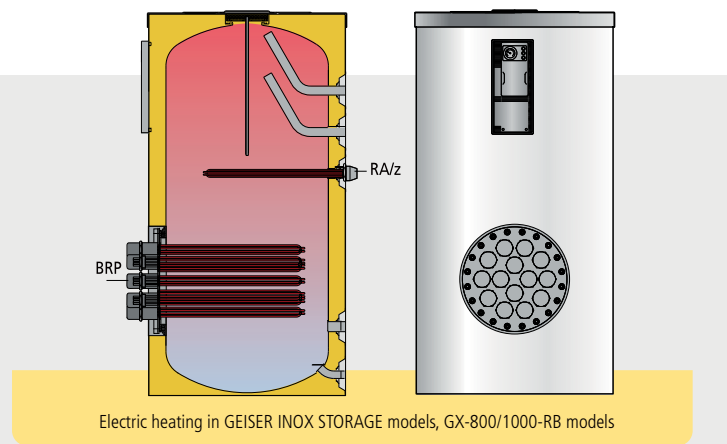



"lapesa" control panels are integrated into the different types of tanks in the **"GEISER INOX"** series.

They are supplied fully wired and mounted on the tank.

The panels include all the necessary components to control the temperature of the DHW stored in the tank and for the thermostatic control of the installation's heating equipment.

Any of the standard control panels fitted in tanks can be replaced by another type of control panel, if the installation so requires.

CONTROL PANEL COMPONENTS:

- [Te°] Thermometer: 0 - 120°C
- [TL°] Control thermostat: 0 - 75°C
- [TL°] Safety thermostat: 90°C
- ❄️/☀️ Switch: winter - summer
- Power on LED: green
- Primary pump LED: amber
- Electric heating element LED: red
- [P] Analog time switch: electric heating element.

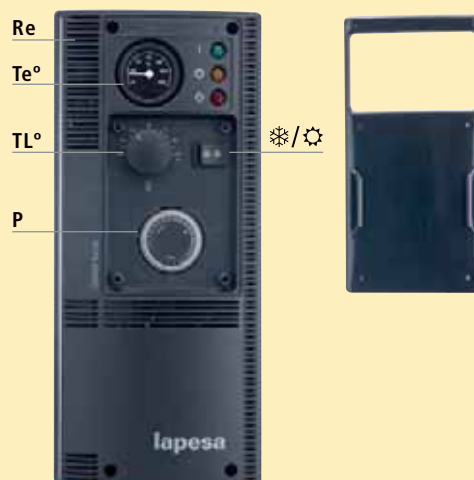

COMPONENTS ON CONTROL PANELS

CONTROL PANEL	INCORPORATED COMPONENTS								
Denomination	Thermometer	Regulation thermostat	Safety thermostat	Switch ON/OFF	SWITCH SUMMER/WINTER	LEDS	Analog time switch	Regulation	Standard installed on tank models "GEISER INOX"
"S" PANEL	YES								GX6 S/P/PAC GX-...-R/RB/HL/HLB
"ST" PANEL	YES	YES						hydraulic primary circuit	GX-...-M1/M2
"K" PANEL	YES	YES	YES	YES	YES	YES		hydraulic primary circuit / electric heating element	GX6 D/DE/DEC
"KP1" PANEL	YES	YES	YES	YES	YES	YES	YES	hydraulic primary circuit / electric heating element with time programming	-



The "GEISER INOX" series are thermally insulated at the factory by direct mould-injection with CFC and HCFC-free PU material. This system guarantees a perfectly regular insulation thickness with optimum material density. The thicknesses indicated in the table refer to the circular tank body, but the insulation is much thicker on the top part (up to four times greater). Because the top part of the tank has better thermal protection, heat losses are much lower than those specified by the most stringent regulations, such as the DIN 4753/8 standard.



Rigid, mould-injected PU insulating material

- *Minimal heat loss!*
- *For hot and cold water!*
- *No condensation on tank body!*
- *Compact block, no joints!*

TABLE OF THERMAL INSULATION: GEISER INOX SERIES

Minimum thickness of equivalent insulation with other insulating materials (mm)

Serie	Type	Model	Thermal insulation k= 0,025 W/m °K	Insulation thickness PU (mm.)	Static heat losses EN 12897 (W)	ErP (EU 812/2013)	Minimum thickness of equivalent insulation with other insulating materials (mm)		
							Flexible polyurethane foam* k= 0,040 W/m °K	Rockwool* k= 0,034 - 0,042 W/m °K	Fiberglass* k= 0,035 - 0,046 W/m °K
GEISER INOX	DOUBLE WALL	GX6-S/D/DEC 90	PU	40	45	B	65	55 - 70	55 - 75
GEISER INOX		GX6-S/D/DEC 130	PU	40	50	B	65	55 - 70	55 - 75
GEISER INOX		GX6-S/D/DEC 190	PU	40	58	B	65	55 - 70	55 - 75
GEISER INOX		GX6-S/D/DEC 260	PU	40	63	B	65	55 - 70	55 - 75
GEISER INOX		GX6-S/D/DEC 400	PU	40	99	C	65	55 - 70	55 - 75
GEISER INOX		GX6-S/D/DEC 600	PU	40	103	C	65	55 - 70	55 - 75
GEISER INOX		GX6-DE 140	PU	55	49	B	65	55 - 70	55 - 75
GEISER INOX		GX6-DE 180	PU	55	53	B	65	55 - 70	55 - 75
GEISER INOX		GX6-DE 215	PU	55	56	B	65	55 - 70	55 - 75
GEISER INOX		GX6-DE 260	PU	55	61	B	65	55 - 70	55 - 75
GEISER INOX		GX6-DE 400	PU	40	99	C	65	55 - 70	55 - 75
GEISER INOX		GX6-DE 600	PU	40	103	C	65	55 - 70	55 - 75
GEISER INOX		GX6-TS 180	PU	45/160	52	B	75/260	65/220 - 80/280	65/220-85/300
GEISER INOX		GX6-TS 240	PU	45/160	57	B	75/260	65/220 - 80/280	65/220-85/300
GEISER INOX		GX6-P/PAC 300	PU	40	62	B	65	55 - 70	55 - 75
GEISER INOX		GX6-P/PAC 400	PU	40	99	C	65	55 - 70	55 - 75
GEISER INOX		GX6-P/PAC 600	PU	40	103	C	65	55 - 70	55 - 75
GEISER INOX		GX6-P/PAC 800	PU	80	87	B	130	110 - 140	115 - 160
GEISER INOX		GX6-P/PAC/DE 1000	PU	80	113	C	130	110 - 140	115 - 160
GEISER INOX		COIL - STORAGE	GX-150-M1	PU	55	41	B	100	85 - 105
GEISER INOX	GX-200-R/M1/M2/HL		PU	60	44	B	100	85 - 105	85 - 120
GEISER INOX	GX-300-R/M1/M2/HL		PU	60	62	B	100	85 - 105	85 - 120
GEISER INOX	GX-400-R/M1/M2		PU	60	75	B	100	85 - 105	85 - 120
GEISER INOX	GX-500-R/M1/M2/HL		PU	60	81	B	100	85 - 105	85 - 120
GEISER INOX	GX-800-R/M1/M2		PU	80	87	B	130	110 - 140	115 - 160
GEISER INOX	GX-800-RB/M1B/M2B/HLB		PU	80	95	B	130	110 - 140	115 - 160
GEISER INOX	GX-1000-R/M1/M2/HL		PU	80	113	C	130	110 - 140	115 - 160
GEISER INOX	GX-1000-RB/M1B/M2B/HLB		PU	80	123	C	130	110 - 140	115 - 160
GEISER INOX	GX-150-TSM		PU	45/160	55	B	75/260	65/220 - 80/280	65/220-85/300
GEISER INOX	GX-200-TSM		PU	45/160	59	B	75/260	65/220 - 80/280	65/220-85/300

(*) Detachable systems can lose up to 25% of the insulating capacity overall, so that in that case the insulation thickness will increased proportionally



The "GEISER INOX" series do not require cathodic protection in normal conditions of use with drinking water (European Directive 98/83/CE). However, depending on the installation site, drinking water conditions may differ greatly from the potability requirements established by current regulations. In this case, and taking as a reference a chloride content limit of 150 mg/l, we recommend incorporating a permanent, maintenance-free "lapesa correx-up" cathodic protection system in the storage tank.

"lapesa correx-up"
permanent cathodic
protection system.

Totally automatic!
Maintenance free!



"lapesa correx-up" permanent cathodic protection system: Maintenance-free permanent cathodic protection unit. These anodes do not wear out and they emit the necessary electric current automatically, providing the tank with cathodic protection via an individual potentiostat for each anode, connected to the mains electricity.



ACCESSORIES - GEISER INOX

EXTERNAL LININGS

External linings for "GEISER INOX" tanks.
Standard external lining: WHITE / RAL 9016.



WHITE: RAL 9016



GREY: RAL 7045



BLUE: RAL 5015

ALUNOX EXTERNAL LINING

External aluminium sheet lining. ALUNOX external lining is supplied ready-mounted on the tank, over the PU insulation.



ACCESSORIES - GEISER INOX



SAFETY GROUP.

- Safety group set at 7 bar and 3/4" connection.
- Set of safety valve, non-return valve, stopcock and connection from trap to drain.

ELECTRIC HEATING ELEMENT. DOUBLE-WALL MODELS.

Electric heating element in AISI 321, specifically for "GEISER INOX" DOUBLE-WALL tanks, "D" and "DEC" models.
Characteristics and power range: page: 38 -ELECTRIC HEATING-



THREADED ELECTRIC HEATING ELEMENT, STORAGE AND COIL MODELS.

Low charge density, threaded immersion electric element in Incoloy for "GEISER INOX" STORAGE and COIL tanks, "R", "RB", "M1" and "M2" models.
Characteristics and power range: page: 38 -ELECTRIC HEATING-

FLANGED ELECTRIC HEATING ELEMENT, STORAGE AND COIL MODELS.

Low charge density, flanged immersion electric element, in Incoloy, for "GEISER INOX" STORAGE and COIL tanks, "R", "M1" and "M2" models.

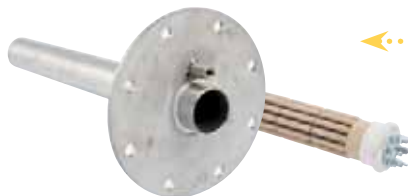
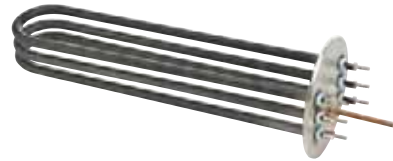

CERAMIC ELECTRIC HEATING ELEMENT, STORAGE AND COIL MODELS.

Sheathed ceramic electric element for "GEISER INOX" STORAGE and COIL tanks, "R", "M1" and "M2" models.
Characteristics and power range: page: 38 -ELECTRIC HEATING-

THREADED ELECTRIC HEATING ELEMENT, DOUBLE WALL MODELS.

Electric element in AISI 321 specifically for "GEISER INOX" DOUBLE-WALL tanks, "DE", "P" and "PAC" models.
Characteristics and power ratings: page: 38 -ELECTRIC HEATING-



"LAPESA CORREX-UP" CATHODIC PROTECTION SYSTEM.

"lapesa correx-up" permanent cathodic protection unit for "GEISER INOX" tanks in installations with aggressive water.

REGULATION AND CONTROL PANELS.

Regulation and control panels for "GEISER INOX" tanks.
Characteristics / applications: page: 40 -REGULATION AND CONTROL-





MASTER INOX - STAINLESS STEEL

STORAGE models, energy savings!

Designed to provide extraordinary storage capacity that translates directly into real savings. Their overdimensioned rigid, mould-injected PU thermal insulation maintains DHW storage temperature for long periods, providing users with continued savings throughout the life of the storage tank.

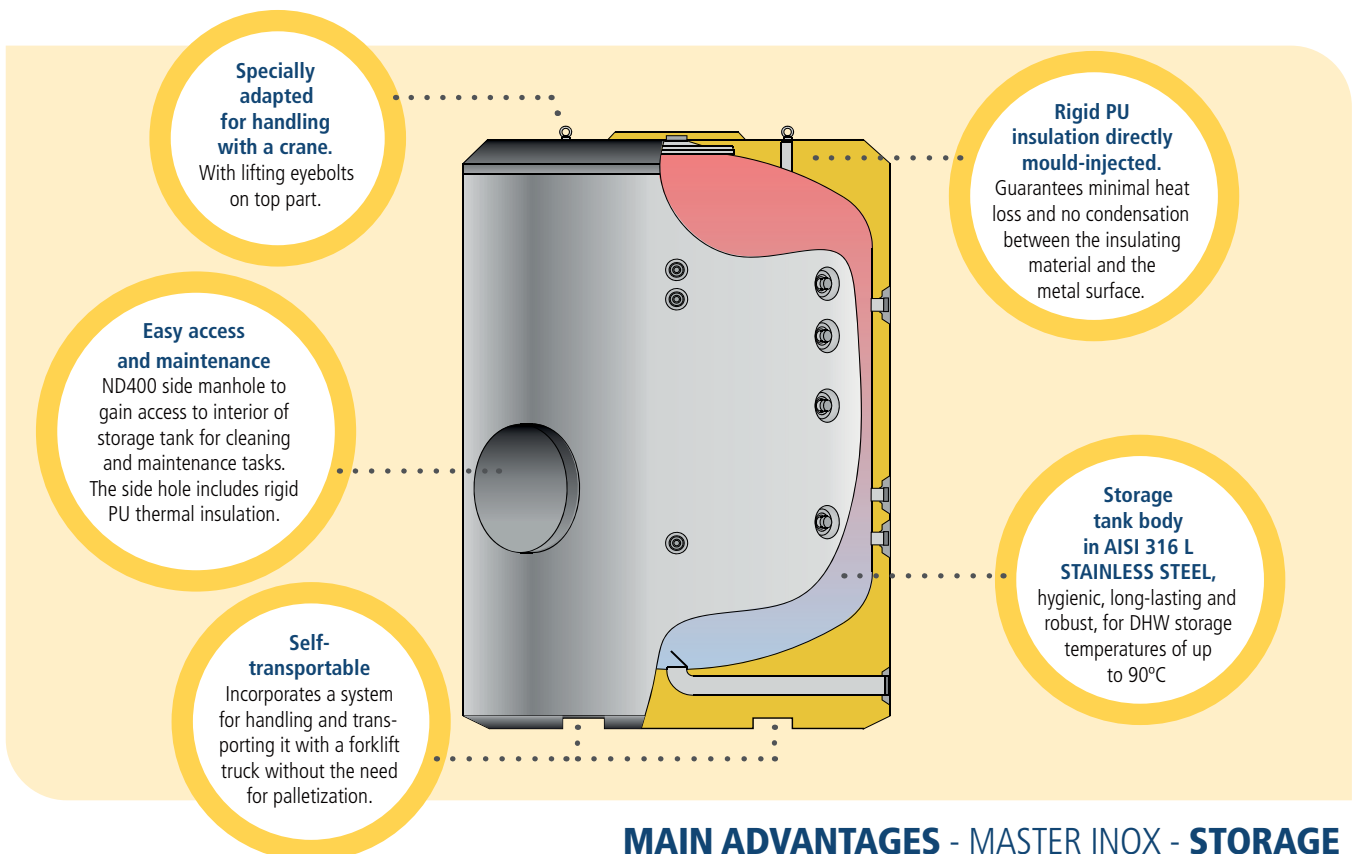

MAIN ADVANTAGES - MASTER INOX - STORAGE

DHW PRODUCTION/STORAGE TANKS MASTER INOX - STORAGE

lapesa

LARGE CAPACITY STORAGE TANKS: Designed to provide an extraordinary storage capacity that translates directly into real savings.

- CAPACITIES from 1500 to 6000 litres -

Storage tanks ready for installation with plate heat exchanger and/or electric heating elements as the heating source.

MAXIMUM STORAGE CAPACITY: Extra thick, rigid PU insulation that minimizes heat losses of stored DHW (see HEAT INSULATION chapter, page: 60)

LONG-LASTING PRODUCT: Nickel-chromium-molybdenum STAINLESS STEEL DHW storage tank, highly resistant to pitting caused by halogen elements such as chlorine in drinking water. This is the material used to manufacture all of the models in our "MASTER INOX" series.

ELECTRIC HEATING: Ready to be fitted with Incoloy, low charge density electric immersion elements or with sheathed ceramic heating elements (see ELECTRIC HEATING chapter, page: 58)

EASY TO MAINTAIN: With access to tank interior through ND400 side manhole, for inspection and cleaning.



EASY TO HANDLE AND TRANSPORT: Our "MASTER" storage tanks are designed for easy handling and transport to the place of installation.

They have an integrated system for handling and transporting by forklift truck, which facilitates handling operations enormously as there is no need to palletize the product which, given its weight and size, would make handling difficult.

The tanks are also equipped with lifting eyebolts on the top part so that if they have to be placed in a high area they can be lifted with an overhead hoist.



TRANSPORT SYSTEM: Openings/ducts under the tank for easier handling with pallet trucks (from 1500 litres or more).



FEATURES COMMON TO ALL "MASTER INOX" STORAGE MODELS:

- DHW storage tanks in **AISI 316 L stainless steel**
- Capacities: **1500, 2000, 2500, 3000, 3500, 4000, 5000 and 6000 litres**
- Maximum working pressure of DHW storage tank: **8 bar** (optional: 10 and 12 bar)
- Maximum working temperature of DHW storage tank: **90 °C**
- Thermal insulation: **Rigid, mould-injected PU** (CFC/HCFC-free, 0.025 W/m²K)
- Tanks for VERTICAL installation on floor. (OPTIONAL, HORIZONTAL position - please consult us-)

lapesa storage tanks have minimal heat losses and for this reason are considered to be one of the products with the greatest storage capacity on the market.

CE

lapesa
Solutions



MASTER INOX "RB"

DWH STORAGE tanks, from **1500 to 6000** litre capacity.

DHW production is by an external heat exchange system (plate heat exchanger)

They can be fitted with immersion electric elements or ceramic electric elements as the main and/or backup heating system.

With ND400 side manhole for access to interior of tank for inspection, cleaning treatments and maintenance.

Thermally insulated with rigid, mould-injected, 80 mm-thick, PU polyurethane foam, with insulating piece in same material on the ND400 side manhole

As an option, PVC padded external lining and set of trims, or ALUNOX aluminium sheet lining can be supplied (see ACCESSORIES chapter, page: 61)

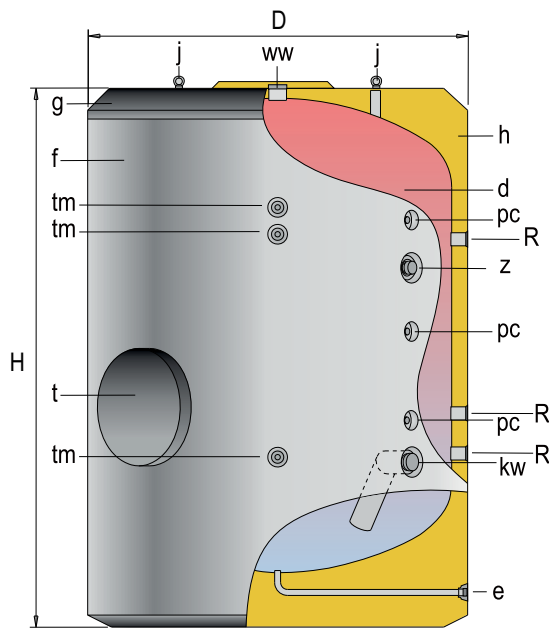

t - Manhole ND400
 d - DHW tank
 f - External lining
 g - Top cover
 h - Thermal insulation
 j - Lifting eyes

GENERAL CHARACTERISTICS		MXV-1500-RB	MXV-2000-RB	MXV-2500-RB	MXV-3000-RB	MXV-3500-RB	MXV-4000-RB	MXV-5000-RB	MXV-6000-RB
DHW capacity	l.	1500	2000	2500	3000	3500	4000	5000	6000
D: external diameter	mm.	1360	1360	1660	1660	1660	1910	1910	1910
H: overall height	mm.	1830	2280	2015	2305	2580	2310	2710	3210
Diagonal	mm.	2281	2655	2611	2841	3068	2998	3316	3735
kw: cold water inlet	" GAS/M	2	2	2	2	3	3	3	3
ww: DHW outlet	" GAS/M	2	2	3	3	3	3	3	3
z: recirculation	" GAS/M	1 1/2	1 1/2	2	2	2	2	2	2
e: drain	" GAS/M	1	1	1	1	1	1	1	2
R: side connection	" GAS/F	2	2	2	2	2	2	2	2
pc: "lapesa correx up" connection	" GAS/F	3/4	3/4	3/4	3/4	3/4	3/4	3/4	3/4
tm: probe tube connection for sensors	" GAS/F	1/2	1/2	1/2	1/2	1/2	1/2	1/2	1/2
Empty weight (approx.)	Kg	265	305	450	485	520	600	670	730

Note: The 6000 litre model includes support legs



MASTER INOX - STAINLESS STEEL

Models with COILS production and efficiency!

Designed to provide great energy storage capacity with an exclusive, high-efficiency DHW production system. Modular heat exchange unit, comprising a set of detachable collectors and coils for DHW production via an external energy source.

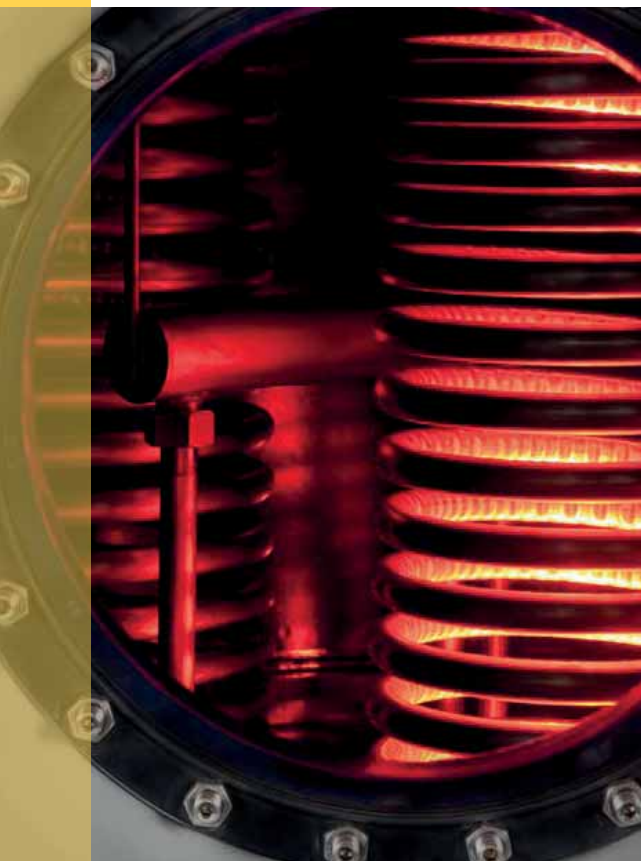

LARGE CAPACITY TANKS FOR DHW PRODUCTION AND STORAGE: Designed for extraordinary energy storage capacity that directly translates into real savings, with an exclusive high-efficiency DHW production system.

- CAPACITIES from 1500 to 6000 litres -

The overdimensioned, rigid, mould-injected PU thermal insulation maintains the DHW storage temperature over long periods of time without requiring additional energy input. This means less start-ups and adjustments of external energy sources, which in turn translates into less energy consumption.

Storage tanks that incorporate a heat exchange system comprising a set of collectors and coils that are detachable from the inside of the storage tank, for DHW production via an external energy source (see DHW PRODUCTION chapter, page: 54)

LONG-LASTING PRODUCT: Nickel-chromium-molybdenum STAINLESS STEEL DHW storage tank, highly resistant to pitting caused by halogen elements such as chlorine in drinking water. This is the material used to manufacture all of the models in our **"MASTER INOX"** series.

DHW PRODUCTION/STORAGE TANKS MASTER INOX - COILS

lapesa

ANTI-LEGIONELLA DESIGN: The design of the complete range of "MASTER INOX" tanks adheres to all of the "Treatment and Prevention of Legionellosis" criteria specified in current UNE standards and EC Directives and, in particular, in the R.D. 865/2003 and the RITE (Regulations on Thermal Installations in Buildings).

The anti-legionella design applies to the storage tank unit and its internal DHW production system.

LARGE DHW PRODUCTION CAPACITY: A set of separate collectors and coils, made of STAINLESS STEEL, are mounted inside the storage tank, allowing the heat exchange surface to be dimensioned in accordance with the power required (up to 10 m² in the 5000 litre model), adapted to traditional energy sources or to the use of renewable energies.

This exclusive **lapesa** DHW production system for large capacity tanks saves on installation space and allows total or partial maintenance of the unit, guaranteeing the continuous service of the installation.

EASY TO MAINTAIN: With access to tank interior through a ND400 side manhole for inspection and cleaning of the storage tank and/or coil system.

MAXIMUM STORAGE CAPACITY: Extra thick, rigid, PU mould-injected insulation that minimizes heat losses of stored DHW (see HEAT INSULATION chapter, page: 60).

ELECTRIC HEATING: Ready to be fitted with Incoloy, low charge density electric immersion elements or with sheathed ceramic heating elements, as backup electric heating (see ELECTRIC HEATING chapter, page: 58).

EASY TO HANDLE AND TRANSPORT: Our "MASTER" storage tanks are designed for easy handling and transport to the place of installation.

They have an integrated system for handling and transporting by forklift truck, which facilitates handling operations enormously, as there is no need to palletize the product which, given its weight and size, would make handling difficult.

The tanks are also equipped with lifting eyebolts on the top part so that if they have to be placed in a high area they can be lifted with an overhead hoist.



TRANSPORT SYSTEM: Openings/ducts under the tank for easier handling with pallet trucks (from 1500 litres or more).



FEATURES COMMON TO ALL "MASTER INOX" COILS MODELS:

- DHW storage tanks in **AISI 316 L stainless steel**
- Capacities: **1500, 2000, 2500, 3000, 3500, 4000, 5000 and 6000 litres**
- Maximum working pressure of DHW storage tank: **8 bar** (optional: 10 and 12 bar)
- Maximum working temperature of DHW storage tank: **90 °C**
- Maximum pressure of set of coils: **25 bar**
- Maximum temperature of set of coils: **110 °C** (up to 200 °C with special high temperature seals)
- Thermal insulation: **Rigid, mould-injected PU** (CFC/HCFC-free, 0.025 W/m²K)
- Tanks for VERTICAL installation on floor. (OPTIONAL, HORIZONTAL position - please consult us-)

MAIN ADVANTAGES - MASTER INOX - COILS

Specially adapted for handling with a crane.
With lifting eyebolts on top part.

Easy access and maintenance
ND400 side manhole to access interior of storage tank for cleaning and maintenance tasks. The side hole includes rigid PU thermal insulation.

Self-transportable
With an integrated system for handling and transporting by forklift truck, which facilitates handling without requiring palletization.

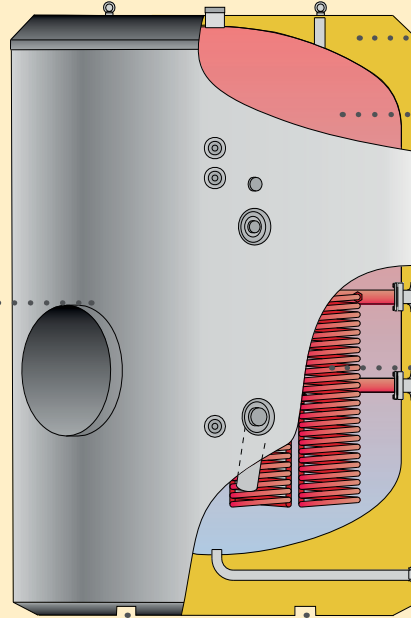

Rigid PU insulation directly mould-injected.
Guarantees minimal heat loss and no condensation between the insulating material and the metal surface.

Storage tank body in AISI 316 L STAINLESS STEEL,
hygienic, long-lasting and robust, for DHW storage temperatures of up to 90°C

Modular, detachable stainless steel coils
Designed to heat from the lowest zone in the tank, they guarantee the greatest DHW production capacity, taking maximum advantage of the tank capacity and acting as a perfect anti-legionella system.

lapesa's exclusive modular coils system for LARGE CAPACITY tanks allows the unit to be adapted to the thermal power required, also enabling separate intervention from the storage tank.

lapesa

Solutions

DHW PRODUCTION/STORAGE TANKS

MASTER INOX - COILS

MASTER INOX "SB"

DWH PRODUCTION/STORAGE tanks, from **1500** to **6000** litre capacity.

With **detachable coils system** for DHW production via an external energy source.

They can be fitted with immersion electric elements or ceramic electric elements on the top part of the tank, as backup heating.

With ND400 side manhole for access to interior of tank for inspection, cleaning treatments and maintenance tasks.

Thermally insulated with rigid, mould-injected, 80 mm-thick, PU polyurethane foam, with insulating piece in same material on the ND400 side manhole

As an option PVC padded external lining and set of trims, special outdoor lining or ALUNOX aluminium sheet lining can be supplied. (page: 61)

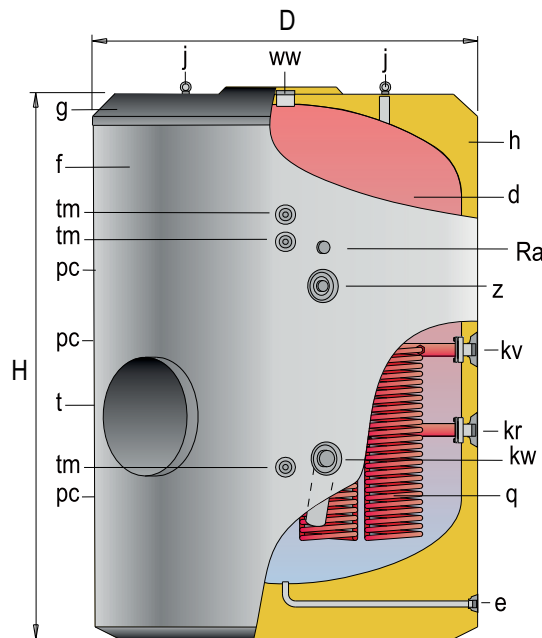

- t - Manhole ND400
- d - DHW tank
- f - External lining
- g - Top cover
- h - Thermal insulation
- j - Lifting eyes
- q - Detachable coils system



GENERAL CHARACTERISTICS		MXV-1500-SB	MXV-2000-SB	MXV-2500-SB	MXV-3000-SB	MXV-3500-SB	MXV-4000-SB	MXV-5000-SB	MXV-6000-SB
DHW capacity	l.	1500	2000	2500	3000	3500	4000	5000	6000
D: external diameter	mm.	1360	1360	1660	1660	1660	1910	1910	1910
H: overall height	mm.	1830	2280	2015	2305	2580	2310	2710	3210
Diagonal	mm.	2281	2655	2611	2841	3068	2998	3316	3735
kw: cold water inlet	" GAS/M	2	2	2	2	3	3	3	3
ww: DHW outlet	" GAS/M	2	2	3	3	3	3	3	3
z: recirculation	" GAS/M	1 1/2	1 1/2	2	2	2	2	2	2
e: drain	" GAS/M	1	1	1	1	1	1	1	2
R: side connection	" GAS/F	2	2	2	2	2	2	2	2
pc: "lapesa correx up" connection	" GAS/F	3/4	3/4	3/4	3/4	3/4	3/4	3/4	3/4
tm: probe tube connection for sensors	" GAS/F	1/2	1/2	1/2	1/2	1/2	1/2	1/2	1/2
kv: primary input	" GAS/M	2	2	2	2	2	2	2	2
kr: primary return	" GAS/M	2	2	2	2	2	2	2	2
Coils set heating surface	m ²	2,8	3,4	4,8	5	6,7	6,7	8,4	8,4
Empty weight (approx.)	Kg	305	345	485	535	575	650	720	805

Note: The 6000 litre model includes support legs

MASTER INOX "SSB"

DHW PRODUCTION/STORAGE tanks, from **1500** to **6000** litre capacity.

Set of OVERDIMENSIONED coils for DHW production, specifically designed for the application of RENEWABLE ENERGIES, in particular, **SOLAR ENERGY**.

Heat exchange surfaces in the whole range comply with RITE requirements for SOLAR installations.

They can be fitted with immersion electric elements or ceramic electric elements on the top part of the tank, as backup heating.

With ND400 side manhole for access to interior of tank for inspection, cleaning treatments and maintenance.

Thermally insulated with rigid, mould-injected, 80 mm-thick, PU polyurethane foam, with insulating piece in same material on the ND400 side manhole.

Optional supply of PVC padded external lining and set of trims, special lining for exterior or ALUNOX aluminium sheet lining (page: 61)

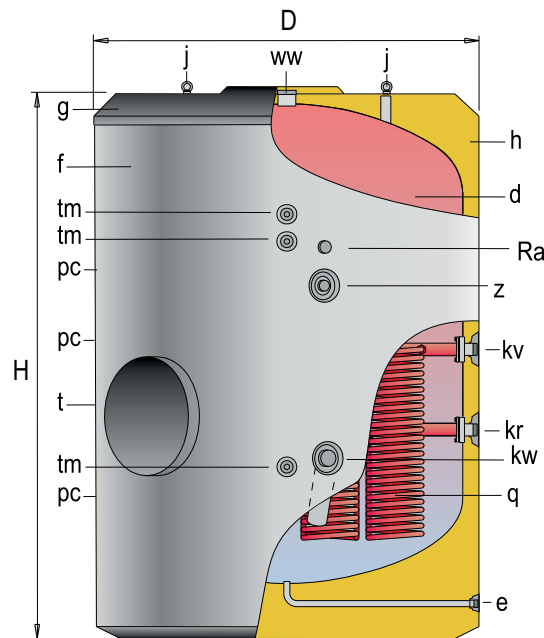

- t - Manhole ND400
- d - DHW tank
- f - External lining
- g - Top cover
- h - Thermal insulation
- j - Lifting eyes
- q - Detachable coils system

GENERAL CHARACTERISTICS		MXV-1500-SSB	MXV-2000-SSB	MXV-2500-SSB	MXV-3000-SSB	MXV-3500-SSB	MXV-4000-SSB	MXV-5000-SSB	MXV-6000-SSB
DHW capacity	l.	1500	2000	2500	3000	3500	4000	5000	6000
D: external diameter	mm.	1360	1360	1660	1660	1660	1910	1910	1910
H: overall height	mm.	1830	2280	2015	2305	2580	2310	2710	3210
Diagonal	mm.	2281	2655	2611	2841	3068	2998	3316	3735
kw: cold water inlet	" GAS/M	2	2	2	2	3	3	3	3
ww: DHW outlet	" GAS/M	2	2	3	3	3	3	3	3
z: recirculation	" GAS/M	1 1/2	1 1/2	2	2	2	2	2	2
e: drain	" GAS/M	1	1	1	1	1	1	1	2
R: side connection	" GAS/F	2	2	2	2	2	2	2	2
pc: "lapesa correx up" connection	" GAS/F	3/4	3/4	3/4	3/4	3/4	3/4	3/4	3/4
tm: probe tube connection for sensors	" GAS/F	1/2	1/2	1/2	1/2	1/2	1/2	1/2	1/2
kv: primary input	" GAS/M	2	2	2	2	2	2	2	2
kr: primary return	" GAS/M	2	2	2	2	2	2	2	2
Coils set heating surface	m ²	4,2	5,0	6,1	8,4	8,4	8,4	10,0	10,0
Empty weight (approx.)	Kg	315	365	500	565	590	665	745	817

Note: The 6000 litre model includes support legs

DHW PRODUCTION/STORAGE TANKS MASTER INOX - COILS

MASTER INOX "S2B / SS2B"

DHW PRODUCTION/STORAGE tanks, **2000, 3500, 5000** and **6000** litre capacity.

"SB" and "SSB" base models with **TWO detachable coil systems** for DHW production via two combined external energy sources.

With ND400 side manhole for access to interior of tank for inspection, cleaning treatments and maintenance.

Thermally insulated with rigid, mould-injected, 80 mm-thick, PU polyurethane foam, with insulating piece in same material on the ND400 side manhole.

Optional supply of PVC padded external lining and set of trims or ALUNOX aluminium sheet lining (page: 61)

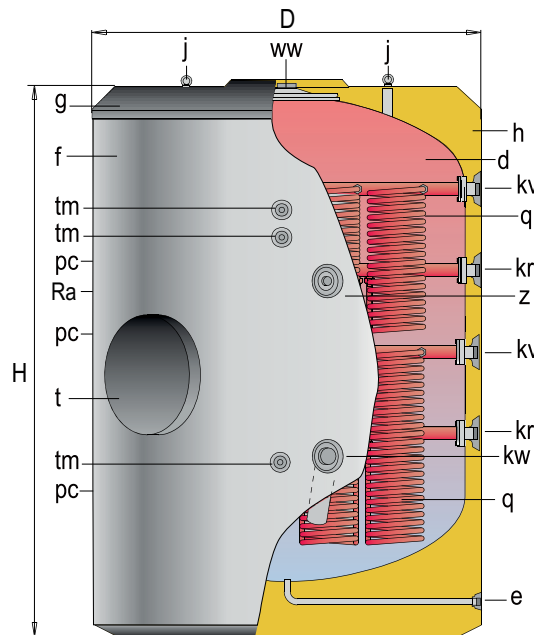

- t - Manhole ND400
- d - DHW tank
- f - External lining
- g - Top cover
- h - Thermal insulation
- j - Lifting eyes
- q - Detachable coils system



GENERAL CHARACTERISTICS		MXV-2000 S2B / SS2B	MXV-3500 S2B / SS2B	MXV-5000 S2B / SS2B	MXV-6000 S2B / SS2B
DHW capacity	l.	2000	3500	5000	6000
D: external diameter	mm.	1360	1660	1910	1910
H: overall height	mm.	2280	2580	2710	3210
Diagonal	mm.	2655	3068	3316	3735
kw: cold water inlet	" GAS/M	2	3	3	3
ww: DHW outlet	" GAS/M	2	3	3	3
z: recirculation	" GAS/M	1 1/2	2	2	2
e: drain	" GAS/M	1	1	1	2
pc: "lapesa correx up" connection	" GAS/F	3/4	3/4	3/4	3/4
Ra: side connection	" GAS/F	2	2	2	2
tm: probe tube connection for sensors	" GAS/F	1/2	1/2	1/2	1/2
kv: primary input	" GAS/M	2	2	2	2
kr: primary return	" GAS/M	2	2	2	2
Lower coils set heating surface "S2B"	m ²	3,4	6,7	8,4	8,4
Lower coils set heating surface "SS2B"	m ²	5,0	8,4	10,0	10,0
Upper coils set heating surface "S2B" / "SS2B"	m ²	1,7/3,1	3,2/4,0	4,0/4,8	4,0/4,8
Empty weight (approx.) "S2B" / "SS2B"	Kg	374 / 394	615 / 630	765 / 790	862 / 874

Note: The 6000 litre model includes support legs

MASTER INOX - COILS - SB [Continuous flow DHW production (liters/hour) 10°C - 45°C]

PRIMARY INPUT TEMPERATURE °C		55 °C		70 °C		80 °C		90 °C	
tank model	primary pump flow (m³/h)	KW	DHW (l/h)	KW	DHW (l/h)	KW	DHW (l/h)	KW	DHW (l/h)
MXV-1500-SB	3	39	960	72	1772	98	2411	119	2928
	5	46	1132	85	2092	118	2904	143	3519
	8	52	1280	98	2411	137	3371	166	4085
MXV-2000-SB	3	44	1083	86	2116	109	2682	136	3347
	5	51	1255	104	2559	133	3273	165	4060
	8	58	1427	121	2977	154	3789	191	4700
MXV-2500-SB	3	53	1304	92	2264	119	2928	146	3593
	5	63	1550	113	2781	147	3617	180	4429
	8	72	1772	132	3248	172	4232	211	5192
MXV-3000-SB	3	61	1501	107	2633	141	3470	174	4282
	5	74	1821	134	3297	178	4380	220	5414
	8	86	2116	158	3888	212	5217	262	6447
MXV-3500-SB	3	71	1747	132	3248	181	4454	224	5512
	5	87	2141	165	4060	228	5610	284	6988
	8	102	2510	196	4823	270	6644	340	8366
MXV-4000-SB	3	71	1747	132	3248	181	4454	224	5512
	5	87	2141	165	4060	228	5610	284	6988
	8	102	2510	196	4823	270	6644	340	8366
MXV-5000-SB	3	83	2042	156	3839	211	5192	263	6472
	5	102	2510	197	4848	268	6595	337	8293
	8	120	2953	234	5758	321	7899	406	9990
MXV-6000-SB	3	83	2042	156	3839	211	5192	263	6472
	5	102	2510	197	4848	268	6595	337	8293
	8	120	2953	234	5758	321	7899	406	9990

MASTER INOX - COILS - SSB [Continuous flow DHW production (liters/hour) 10°C - 45°C]

PRIMARY INPUT TEMPERATURE °C		55 °C		70 °C		80 °C		90 °C	
tank model	primary pump flow (m³/h)	KW	DHW (l/h)	KW	DHW (l/h)	KW	DHW (l/h)	KW	DHW (l/h)
MXV-1500-SSB	3	53	1304	92	2264	119	2928	146	3593
	5	63	1550	113	2781	147	3617	180	4429
	8	72	1772	132	3248	172	4232	211	5192
MXV-2000-SSB	3	61	1501	107	2633	141	3470	174	4282
	5	74	1821	134	3297	178	4380	220	5414
	8	86	2116	158	3888	212	5217	262	6447
MXV-2500-SSB	3	64	1575	119	2928	161	3962	199	4897
	5	78	1919	149	3666	204	5020	251	6176
	8	90	2215	177	4355	243	5979	299	7357
MXV-3000-SSB	3	83	2042	156	3839	211	5192	263	6472
	5	102	2510	197	4848	268	6595	337	8293
	8	120	2953	234	5758	321	7899	406	9990
MXV-3500-SSB	3	83	2042	156	3839	211	5192	263	6472
	5	102	2510	197	4848	268	6595	337	8293
	8	120	2953	234	5758	321	7899	406	9990
MXV-4000-SSB	3	83	2042	156	3839	211	5192	263	6472
	5	102	2510	197	4848	268	6595	337	8293
	8	120	2953	234	5758	321	7899	406	9990
MXV-5000-SSB	3	100	2461	177	4364	243	5973	301	7401
	5	125	3076	226	5569	314	7715	392	9657
	8	148	3642	271	6677	379	9319	477	11732
MXV-6000-SSB	3	100	2461	177	4364	243	5973	301	7401
	5	125	3076	226	5569	314	7715	392	9657
	8	148	3642	271	6677	379	9319	477	11732

MASTER INOX - COILS - SB [Continuous flow DHW production (liters/hour) 10°C - 60°C]

PRIMARY INPUT TEMPERATURE °C		70 °C		80 °C		90 °C	
tank model	primary pump flow (m³/h)	KW	DHW (l/h)	KW	DHW (l/h)	KW	DHW (l/h)
MXV-1500-SB	3	46	792	73	1257	94	1619
	5	55	947	89	1533	114	1964
	8	64	1102	103	1774	132	2274
MXV-2000-SB	3	55	947	80	1378	107	1843
	5	67	1154	98	1688	131	2256
	8	78	1344	114	1964	152	2618
MXV-2500-SB	3	59	1016	87	1499	115	1981
	5	72	1240	108	1860	143	2463
	8	85	1464	128	2205	168	2894
MXV-3000-SB	3	68	1171	104	1791	137	2360
	5	86	1481	131	2256	174	2997
	8	102	1757	157	2704	209	3600
MXV-3500-SB	3	85	1464	133	2291	177	3049
	5	106	1826	168	2894	226	3893
	8	126	2170	200	3445	270	4651
MXV-4000-SB	3	85	1464	133	2291	177	3049
	5	106	1826	168	2894	226	3893
	8	126	2170	200	3445	270	4651
MXV-5000-SB	3	100	1722	155	2670	208	3583
	5	127	2188	198	3411	268	4616
	8	151	2601	238	4100	323	5564
MXV-6000-SB	3	100	1722	155	2670	208	3583
	5	127	2188	198	3411	268	4616
	8	151	2601	238	4100	323	5564

MASTER INOX - COILS - SSB [Continuous flow DHW production (liters/hour) 10°C - 60°C]

PRIMARY INPUT TEMPERATURE °C		70 °C		80 °C		90 °C	
tank model	primary pump flow (m³/h)	KW	DHW (l/h)	KW	DHW (l/h)	KW	DHW (l/h)
MXV-1500-SSB	3	59	1016	87	1499	115	1981
	5	72	1240	108	1860	143	2463
	8	85	1464	128	2205	168	2894
MXV-2000-SSB	3	68	1171	104	1791	137	2360
	5	86	1481	131	2256	174	2997
	8	102	1757	157	2704	209	3600
MXV-2500-SSB	3	76	1312	118	2040	157	2697
	5	96	1654	151	2595	199	3429
	8	114	1969	180	3107	238	4103
MXV-3000-SSB	3	100	1722	155	2670	208	3583
	5	127	2188	198	3411	268	4616
	8	151	2601	238	4100	323	5564
MXV-3500-SSB	3	100	1722	155	2670	208	3583
	5	127	2188	198	3411	268	4616
	8	151	2601	238	4100	323	5564
MXV-4000-SSB	3	100	1722	155	2670	208	3583
	5	127	2188	198	3411	268	4616
	8	151	2601	238	4100	323	5564
MXV-5000-SSB	3	113	1948	179	3077	238	4094
	5	144	2477	232	3992	312	5368
	8	172	2964	281	4833	380	6540
MXV-6000-SSB	3	113	1948	179	3077	238	4094
	5	144	2477	232	3992	312	5368
	8	172	2964	281	4833	380	6540

MASTER INOX - UPPER COIL⁽¹⁾ - S2B / SS2B [Continuous flow DHW production (liters/hour) 10°C - 45°C]

PRIMARY INPUT TEMPERATURE °C		55 °C		70 °C		80 °C		90 °C	
tank model	primary pump flow (m ³ /h)	KW	DHW (l/h)	KW	DHW (l/h)	KW	DHW (l/h)	KW	DHW (l/h)
MXV-2000-S2B/SS2B	3	36	886	70	1722	92	2264	115	2830
	5	42	1033	83	2042	110	2707	136	3347
	8	48	1181	95	2338	127	3125	155	3814
MXV-3500-S2B/SS2B	3	50	1230	92	2264	119	2928	147	3617
	5	60	1476	112	2756	145	3568	179	4405
	8	69	1698	131	3224	169	4159	208	5118
MXV-5000-S2B/SS2B	3	58	1427	103	2535	136	3347	168	4134
	5	71	1747	129	3174	170	4183	210	5167
	8	82	2018	152	3740	202	4971	250	6152
MXV-6000-S2B/SS2B	3	58	1427	103	2535	136	3347	168	4134
	5	71	1747	129	3174	170	4183	210	5167
	8	82	2018	152	3740	202	4971	250	6152

(1) DHW productions for the lower coils of S2B models correspond to the productions of the SB models, see page 54.

MASTER INOX - SERPENTÍN⁽²⁾ SUPERIOR - S2B / SS2B [Continuous flow DHW production (liters/hour) 10°C - 60°C]

PRIMARY INPUT TEMPERATURE °C		70 °C		80 °C		90 °C	
tank model	primary pump flow (m ³ /h)	KW	DHW (l/h)	KW	DHW (l/h)	KW	DHW (l/h)
MXV-2000-S2B/SS2B	3	43	741	67	1154	88	1516
	5	53	913	82	1412	108	1860
	8	62	1068	96	1654	126	2170
MXV-3500-S2B/SS2B	3	58	999	86	1481	114	1964
	5	72	1240	106	1826	141	2429
	8	84	1447	125	2153	165	2842
MXV-5000-S2B/SS2B	3	66	1137	100	1722	132	2274
	5	83	1430	125	2153	167	2877
	8	98	1688	150	2584	199	3428
MXV-6000-S2B/SS2B	3	66	1137	100	1722	132	2274
	5	83	1430	125	2153	167	2877
	8	98	1688	150	2584	199	3428

(2) DHW productions for the lower coils of SS2B models correspond to the productions of the SSB models, see page 55.



MASTER INOX - COILS models - SB - (DHW production - peak flow -)

		MXV1500 SB	MXV2000 SB	MXV2500 SB	MXV3000 SB	MXV3500 SB	MXV4000 SB	MXV5000 SB	MXV6000 SB
Peak flow 40°C	L/10'	2925	3900	4875	5850	6825	7800	9750	11800
Peak flow 45°C	L/10'	2500	3325	4175	5000	5850	6675	8350	10050
Peak flow 60°C	L/10'	1750	2325	2925	3500	4075	4675	5850	7075
Peak flow 40°C	L/60'	6675	8150	9625	11675	14240	15200	18500	20550
Peak flow 45°C	L/60'	5600	6850	8125	9825	12055	12875	15625	17340
Peak flow 60°C	L/60'	3400	4225	5050	6125	7450	8000	9750	10990
Continuous flow 40°C	Ltrs/h	4500	5100	5700	7000	8900	8900	10500	10500
Continuous flow 45°C	Ltrs/h	3725	4250	4750	5800	7450	7450	8750	8750
Continuous flow 60°C	Ltrs/h	2000	2300	2550	3150	4000	4000	4700	4700
Heating time (from 10 to 75°C)	Min	77	88	100	97	100	102	109	117
Primary flow	m ³ /h	8	8	8	8	8	8	8	8

Primary input temperature 85°C

MASTER INOX - COILS models - SSB - (DHW production - peak flow -)

		MXV1500 SSB	MXV2000 SSB	MXV2500 SSB	MXV3000 SSB	MXV3500 SSB	MXV4000 SSB	MXV5000 SSB	MXV6000 SSB
Peak flow 40°C	L/10'	2925	3900	4875	5850	6825	7800	10840	12790
Peak flow 45°C	L/10'	2500	3325	4175	5000	5850	6675	9235	10910
Peak flow 60°C	L/10'	1750	2325	2925	3500	4075	4675	6325	7500
Peak flow 40°C	L/60'	7675	9725	11550	14600	15575	16550	21740	23690
Peak flow 45°C	L/60'	6450	8150	9735	12275	13125	13950	18010	19680
Peak flow 60°C	L/60'	3875	4950	5930	7400	7975	8575	11065	12240
Continuous flow 40°C	Ltrs/h	5700	7000	8010	10500	10500	10500	13080	13080
Continuous flow 45°C	Ltrs/h	4750	5800	6675	8750	8750	8750	10530	10530
Continuous flow 60°C	Ltrs/h	2550	3150	3605	4700	4700	4700	5690	5690
Heating time (from 10 to 75°C)	Min	60	65	65	65	76	87	102	110
Primary flow	m ³ /h	8	8	8	8	8	8	8	8

Primary input temperature 85°C

MASTER INOX - COILS models - S2B / SS2B - (DHW production - peak flow -)

UPPER COIL		MXV2000 S2B	MXV3500 S2B	MXV5000 S2B	MXV6000 S2B	MXV2000 SS2B	MXV3500 SS2B	MXV5000 SS2B	MXV6000 SS2B
Peak flow 40°C	L/10'	3900	6825	9750	11800	3900	6825	10840	12790
Peak flow 45°C	L/10'	3325	5850	8350	10050	3325	5850	9235	10910
Peak flow 60°C	L/10'	2325	4075	5850	7075	2325	4075	6325	7500
Peak flow 40°C	L/60'	8150	14240	18500	20550	9725	15575	21740	23690
Peak flow 45°C	L/60'	6850	12055	15625	17340	8150	13125	18010	19680
Peak flow 60°C	L/60'	4225	7405	9750	10990	4950	7975	11065	12240
Continuous flow 40°C	Ltrs/h	5100	8900	10500	10500	7000	10500	13080	13080
Continuous flow 45°C	Ltrs/h	4250	7450	8750	8750	5800	8750	10530	10530
Continuous flow 60°C	Ltrs/h	2300	4000	4700	4700	3150	4700	5690	5690
Heating time (from 10 to 75°C)	Min	88	98	109	117	65	76	102	110
Primary flow	m ³ /h	8	8	8	8	8	8	8	8

Primary input temperature 85°C

The MASTER INOX models can be fitted with electric heating elements:

- "RB/EB" STORAGE models":
MAIN ELECTRIC HEATING and/or
BACKUP ELECTRIC HEATING
- Models "SB/SSB" with COILS:
BACKUP ELECTRIC HEATING

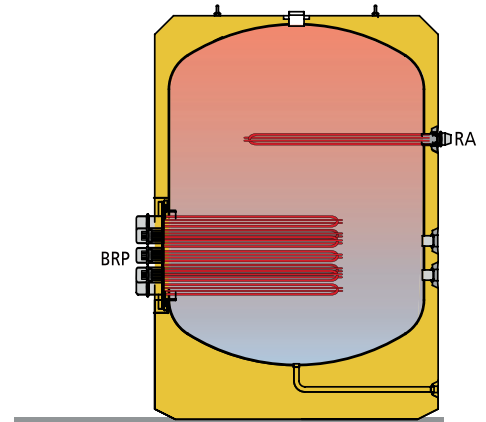

MASTER INOX threaded immersion heating elements , in INCOLOY, for electric heating:

Electric heating element model	KW	V	Thread	Integrated control	IP	length L*	MAIN HEATING and/or BACKUP HEATING	BACKUPHEATING
RA4/2-60H	6,0	230/400	2" M	-	40	797	MXV1500-...6000-RB/EB	MXV1500-...6000-SB/SSB
RA4/2-90H	9,0	230/400	2" M	-	40	1115	MXV1500-...6000-RB/EB	MXV1500-...6000-SB/SSB
RA4/2-120DH	12,0	230/400	2" M	-	40	680	MXV1500-...6000-RB/EB	MXV1500-...6000-SB/SSB
RA4/2-120DHT	12,0	230/401	2" M	Regulation and safety thermostat*	65	680	MXV1500-...6000-RB/EB	MXV1500-...6000-SB/SSB
RA4/2-125DHT	12,5	230/400	2" M	Regulation and safety thermostat*	65	680	MXV1500-...6000-RB/EB	MXV1500-...6000-SB/SSB
RA4/2-150DH	15,0	230/400	2" M	-	40	820	MXV1500-...6000-RB/EB	MXV1500-...6000-SB/SSB
RA4/2-150DHT	15,0	230/400	2" M	Regulation and safety thermostat*	65	820	MXV1500-...6000-RB/EB	MXV1500-...6000-SB/SSB
RA4/2-250DH	25,0	230/400	2" M	-	40	1200	MXV1500-...6000-RB/EB	MXV1500-...6000-SB/SSB
RA4/2-250DHT	25,0	230/400	2" M	Regulation and safety thermostat*	65	1200	MXV1500-...6000-RB/EB	MXV1500-...6000-SB/SSB

(*) Regulation thermostat: o - 75°C (adjusted to 60 °C) / Safety thermostat: 90 °C



HIGH ELECTRIC POWERS:

If high electric power storage tanks have to be installed, the electric heating elements can be grouped together in the ND400 manhole. The "RB" models can be fitted with up to 8 immersion elements in the ND400 side manhole, to obtain a maximum power of 200 KW. For the 2000, 3500, 5000 and 6000 litre models an optional second ND400 manhole can be included to group together up to 16 electric heating elements, for a maximum power of 400 KW.

SPECIAL MANUFACTURE:

The "SB" and "SSB" models can only incorporate electric heating elements in the ND400 manhole if it is moved to the top part of the storage tank, above the set of coils. In this case the electric heating would act as backup heating. As an option, the 2000, 3500, 5000 and 6000 litre models can also include a second ND400 manhole.

In all of the cases the system is supplied with a protective box for the set of heating elements in stainless steel, with a lid.

MXV "RB" Models with threaded immersion heating elements, in ND400 manhole

Tank models MXV "RB"	Number of heating elements on MH ND400	Number of heating elements on 2nd MH ND400 (OPTIONAL)
MXV1500RB	3, 4, 5, 6, 7 u 8	-
MXV2000RB	3, 4, 5, 6, 7 u 8	3, 4, 5, 6, 7 u 8
MXV2500RB	3, 4, 5, 6, 7 u 8	-
MXV3000RB	3, 4, 5, 6, 7 u 8	-
MXV3500RB	3, 4, 5, 6, 7 u 8	3, 4, 5, 6, 7 u 8
MXV4000RB	3, 4, 5, 6, 7 u 8	-
MXV5000RB	3, 4, 5, 6, 7 u 8	3, 4, 5, 6, 7 u 8
MXV6000RB	3, 4, 5, 6, 7 u 8	3, 4, 5, 6, 7 u 8



MXV "SB/SSB" models with threaded immersion heating elements, in ND400 (SPECIAL MANUFACTURE)

(ONLY BACKUP HEATING)

(OPTION 1) Manhole moved to top of tank.

(OPTION 2) Second manhole on top part of tank

Tank models MXV "SB/SSB"	Number of heating elements on MH ND400 (OPTION 1)	Number of heating elements on 2nd MH ND400 (OPTION 2)
MXV1500SB/SSB	3, 4, 5, 6, 7 u 8	-
MXV2000SB/SSB	3, 4, 5, 6, 7 u 8	3, 4, 5, 6, 7 u 8
MXV2500SB/SSB	3, 4, 5, 6, 7 u 8	-
MXV3000SB/SSB	3, 4, 5, 6, 7 u 8	-
MXV3500SB/SSB	3, 4, 5, 6, 7 u 8	3, 4, 5, 6, 7 u 8
MXV4000SB/SSB	3, 4, 5, 6, 7 u 8	-
MXV5000SB/SSB	3, 4, 5, 6, 7 u 8	3, 4, 5, 6, 7 u 8
MXV6000SB/SSB	3, 4, 5, 6, 7 u 8	3, 4, 5, 6, 7 u 8

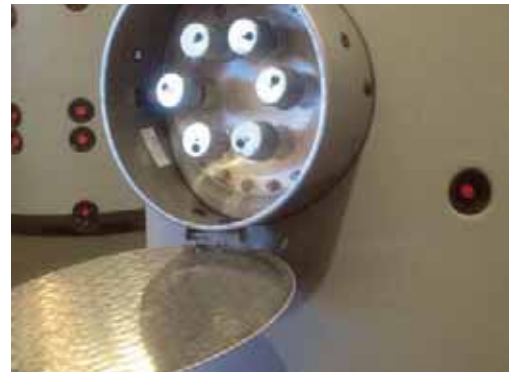

MASTER INOX" sheathed CERAMIC HEATING ELEMENTS on stainless steel plate for ND400

ND400 stainless steel plate with sheaths for ceramic heating elements + no. of heating elements selected. NUMBER OF HEATING ELEMENTS per plate in ND400: 3, 4, 5, 6, 7 or 8

Heating element model	KW	V	length L*	optional application on models MXV	
				MAIN and/or BACKUP HEATING	BACKUP HEATING
RCER-45	4,5	230/400	800	MXV-1500-...6000-RB	MXV-2000/3500/5000/6000-SB/SSB
RCER-60	6,0	230/400	1000		



ELECTRIC HEATING WITH CERAMIC HEATING ELEMENTS. "DRY" SYSTEM

The "dry" system with ceramic electric heating elements means that there is no need to drain the storage tank when fitting/removing or replacing the heating elements.

This system consists of a ND400 stainless steel plate with blind sheaths in the same material that house the ceramic heating elements. With a maximum of 8 units per ND400 plate, this system provides a maximum of 48 KW of electric power.

SPECIAL MANUFACTURE: As an option, the storage tank can be equipped with a second ND400 manhole. In this case, maximum installable power would be 96 KW (only valid for 2000, 3500, 5000 and 6000 litre "RB" models).

In all of the cases the system is supplied with a protective box for the set of heating elements in stainless steel, with a lid.

MXV "RB" models with ceramic ELECTRIC HEATING ELEMENTS, in ND400 manhole

Tank models MXV "RB"	Number of heating elements on MH ND400	Number of heating elements on 2nd MH ND400 (OPTIONAL)
MXV1500RB	3, 4, 5, 6, 7 u 8	-
MXV2000RB	3, 4, 5, 6, 7 u 8	3, 4, 5, 6, 7 u 8
MXV2500RB	3, 4, 5, 6, 7 u 8	-
MXV3000RB	3, 4, 5, 6, 7 u 8	-
MXV3500RB	3, 4, 5, 6, 7 u 8	3, 4, 5, 6, 7 u 8
MXV4000RB	3, 4, 5, 6, 7 u 8	-
MXV5000RB	3, 4, 5, 6, 7 u 8	3, 4, 5, 6, 7 u 8
MXV6000RB	3, 4, 5, 6, 7 u 8	3, 4, 5, 6, 7 u 8



MXV "SB/SSB" models with ceramic ELECTRIC HEATING ELEMENTS, in ND400 manhole

(ONLY BACKUP HEATING)

(OPTION 1) Manhole moved to top of tank.

(OPTION 2) Second manhole on top part of tank

Tank models MXV "SB/SSB"	Number of heating elements on MH ND400 (OPTION 1)	Number of heating elements on 2nd MH ND400 (OPTION 2)
MXV1500SB/SSB	3, 4, 5, 6, 7 u 8	-
MXV2000SB/SSB	3, 4, 5, 6, 7 u 8	3, 4, 5, 6, 7 u 8
MXV2500SB/SSB	3, 4, 5, 6, 7 u 8	-
MXV3000SB/SSB	3, 4, 5, 6, 7 u 8	-
MXV3500SB/SSB	3, 4, 5, 6, 7 u 8	3, 4, 5, 6, 7 u 8
MXV4000SB/SSB	3, 4, 5, 6, 7 u 8	-
MXV5000SB/SSB	3, 4, 5, 6, 7 u 8	3, 4, 5, 6, 7 u 8
MXV6000SB/SSB	3, 4, 5, 6, 7 u 8	3, 4, 5, 6, 7 u 8





The "MASTER INOX" series of tanks are thermally insulated at the factory by direct mould-injection with CFC and HCFC-free PU material.

This system guarantees a perfectly regular insulation thickness with optimum material density. The thicknesses indicated in the table refer to the circular tank body, but the insulation is much thicker on the top part (up to four times greater). Because the top part of the tank has better thermal protection, heat losses are much lower than those specified by the most stringent regulations, such as the DIN 4753/8 standard.



Rigid, mould-injected PU insulating material.

- *Minimal heat loss!*
- *For hot and cold water!*
- *No condensation on tank body!*
- *Compact block, no joints!*

TABLE OF THERMAL INSULATION: MASTER INOX SERIES

Serie	Type	Model	Thermal insulation k= 0.025 W/m °K	Insulation thickness PU (mm.)	Static heat losses EN 12897 (W)	ErP  (EU 812/2013)	Minimum thickness of equivalent insulation with other insulating materials (mm)		
							Flexible polyurethane foam* k= 0,040 W/m °K	Rockwool* k= 0,034 - 0,042 W/m °K	Fiberglass* k= 0,035 - 0,046 W/m °K
MASTER INOX	COIL / STORAGE	MVV-1500-RB/SB/SSB	PU	80	154	C	130	110 - 140	115 - 155
MASTER INOX		MVV-2000-RB/SB/SSB/S2B/SS2B	PU	80	174	C	130	110 - 140	115 - 155
MASTER INOX		MVV-2500-RB/SB/SSB	PU	80	194	C	130	110 - 140	115 - 155
MASTER INOX		MVV-3000-RB/SB/SSB	PU	80	215	C	130	110 - 140	115 - 155
MASTER INOX		MVV-3500-RB/SB/SSB/S2B/SS2B	PU	80	232	C	130	110 - 140	115 - 155
MASTER INOX		MVV-4000-RB/SB/SSB	PU	80	245	C	130	110 - 140	115 - 155
MASTER INOX		MVV-5000-RB/SB/SSB/S2B/SS2B	PU	80	266	C	130	110 - 140	115 - 155
MASTER INOX		MVV-6000-RB/SB/SSB/S2B/SS2B	PU	80	280	C	130	110 - 140	115 - 155

(*) Detachable systems can lose up to 25% of the insulating capacity overall, so that in that case the insulation thickness will increased proportionally



The "MASTER INOX" series do not require cathodic protection in normal conditions of use with drinking water (European Directive 98/83/CE). However, depending on the installation site, drinking water conditions may differ greatly from the drinking water requirements established by current regulations. In this case, and taking as the reference a 150 mg/l chloride content limit, we recommend fitting a permanent, maintenance-free "lapesa correx-up" cathodic protection system in the storage tank.

"lapesa correx-up"
permanent cathodic
protection system:

Totally automatic!

Maintenance free!

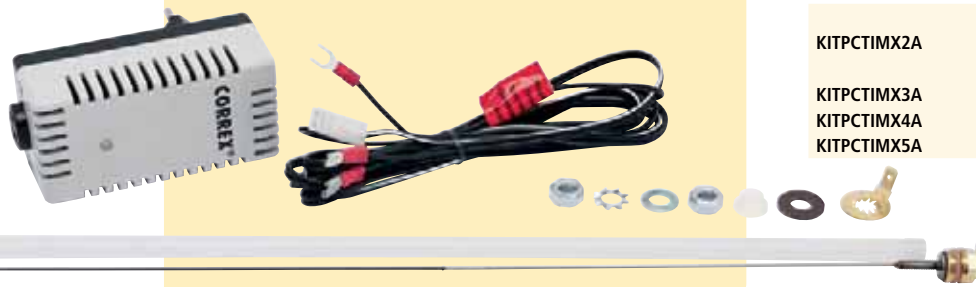

KIT C.P. lapesa correx-up	Applicable to MASTER INOX tanks models:
KITPCTIMX2A	MXV1500RB...3000RB
	MXV1500SB/SSB/EB MXV3000RB...5000RB
KITPCTIMX3A	MXV2000SB/SSB/EB...2500SB/SSB/EB
KITPCTIMX4A	MXV3000SB/SSB/EB...4000SB/SSB/EB
KITPCTIMX5A	MXV5000SB/SSB/EB

"lapesa correx-up" permanent cathodic protection system: Maintenance-free permanent cathodic protection unit. These anodes do not wear out and they emit the necessary electric current automatically, providing the tank with cathodic protection via an individual potentiostat for each anode, connected to the mains electricity.



ACCESSORIES - MASTER INOX



EXTERNAL LINING

External lining for "MASTER INOX" tanks with top cover, ND400 side manhole cover and trims for hydraulic connections. Standard external lining: GREY / RAL 7042.

Capacity (l)	Standard (KIT reference)	Fireproof (KIT reference)	Weatherproof (KIT reference)
1500	FME1500	FME1500	FME1500/EX
2000	FME2000	FME2000	FME2000/EX
2500	FME2500	FME2500	FME2500/EX
3000	FME3000	FME3000	FME3000/EX
3500	FME3500	FME3500	FME3500/EX
4000	FME4000	FME4000	FME4000/EX
5000	FME5000	FME5000	FME5000/EX
6000	FME6000	FME6000	FME6000/EX

ALUNOX EXTERNAL LINING

External aluminium sheet lining. ALUNOX external lining is supplied ready-mounted on the tank, over the PU insulation.

Capacity (l)	Aluminium lining ALUNOX - Ref.
1500	FME1500/ALUNOX-B
2000	FME2000/ALUNOX-B
2500	FME2500/ALUNOX-B
3000	FME3000/ALUNOX-B
3500	FME3500/ALUNOX-B
4000	FME4000/ALUNOX-B
5000	FME5000/ALUNOX-B





2" M THREADED ELECTRIC HEATING ELEMENT.

Low charge density, threaded, immersion electric element in Incoloy for "MASTER INOX" STORAGE and COIL tanks.

Characteristics and power range: page: 54 -ELECTRIC HEATING-

Electric element model	KW	V	Thread	Integrated control
RA4/2-60	6,0	230/400	2" M	-
RA4/2-90	9,0	230/400	2" M	-
RA4/2-120D	12,0	230/400	2" M	-
RA4/2-120DT	12,0	230/401	2" M	Regulation and safety thermostat
RA4/2-125DT	12,5	230/400	2" M	Regulation and safety thermostat
RA4/2-150D	15,0	230/400	2" M	-
RA4/2-150DT	15,0	230/400	2" M	Regulation and safety thermostat
RA4/2-250D	25,0	230/400	2" M	-
RA4/2-250DT	25,0	230/400	2" M	Regulation and safety thermostat

(*) Regulation thermostat 0 -75 °C (adjusted to 60 °C) / Safety thermostat 90 °C

CERAMIC ELECTRIC HEATING ELEMENT, STORAGE AND COIL MODELS.

Sheathed ceramic electric heating element for "MASTER INOX" STORAGE AND COIL tanks, "RB" models in ND400
Characteristics and power range: page: 54 -ELECTRIC HEATING-

Heating element	KW	V
RCER-45	4,5	230/400
RCER-60	6,0	230/400



ND 400 PLATES FOR INSTALLATION OF ELECTRIC HEATING ELEMENTS ON ND400 SIDE MANHOLE.

ND 400 plate and protective hood in stainless steel, with 2" threaded connections to install immersion electric heating elements in ND400 side manhole.

ND400 plate set

TBH2CONEX
TBH4CONEX
TBH5CONEX
TBH6CONEX
TBH7CONEX
TBH8CONEX

(*) Heating elements not included



ND 400 PLATES FOR INSTALLATION OF CERAMIC ELECTRIC HEATING ELEMENTS IN ND400 SIDE MANHOLE.

ND 400 plate and protective hood in stainless steel, for the installation of sheathed ceramic electrical heating elements ("dry" system) in ND400 side manhole.

ND400 plate set

TBH2VAINAS
TBH4VAINAS
TBH5VAINAS
TBH6VAINAS
TBH7VAINAS
TBH8VAINAS

(*) Heating elements not included

DUAL CONTROL AND SAFETY THERMOSTAT

Dual control 0-75° (set at 60°C) and safety 95°C thermostat KIT, with 1/2" x 100 mm threaded sheath and 3/4" -1/2" reduction.

KIT

KIT MASTER double thermostat



0-120°C THERMOMETER

KIT comprising 0-120°C thermometer with 1/2" x 100 mm threaded sheath and 3/4" -1/2" reduction

KIT

KIT MASTER thermometer



0-16 BAR PRESSURE GAUGE

KIT comprising 0-16 bar pressure gauge with 3/4" -1/2" reduction and 1/2" -1/4" reduction

KIT

KIT pressure gauge



P & T PRESSURE AND TEMPERATURE SAFETY VALVE

P & T pressure and temperature safety valve, 8 bar, 92°C

KIT

3/4" P&T valve KIT
1 1/4" P&T valve KIT

PLATE EXCHANGERS

COMPACT PLATE EXCHANGERS		Ref.	Number of plates	Flow rate at 50°C (l/h)	Power (kW) ⁽³⁾	Pressure drop (meters H ₂ O)	A x B x F mm	E mm	C mm	D mm	Connections
Max. working temperature	135 / 155°C ⁽¹⁾	LPIC-01	20	1.000	45	< 3	73 x 192 x 42,32	20,1	40	154	3/4"
Max working pressure	16 / 25 bar ⁽²⁾	LPIC-02	20	2.000	90	< 6	73 x 315 x 42,32	20,1	40	278	3/4"
Applications	Fluid/Fluid	LPIC-03	20	3.000	140	< 6	119 x 289 x 48,8	45	72	243	1"
Chassis	AISI 316	LPIC-04	30	4.000	185	< 6	119 x 289 x 71,2	45	72	243	1"
Plates	AISI 316	LPIC-05	40	5.000	235	< 6	119 x 289 x 93,6	45	72	243	1"
Connections	AISI 316	LPIC-07	40	7.000	325	< 8	119 x 376 x 93,6	45	63	320	1-1/4"
Additional features	Thermal Insulation	LPIC-10	60	10.000	465	< 8	119 x 376 x 136,4	45	63	320	1-1/4"
		LPIC-12	70	12.000	560	< 8	119 x 376 x 160,8	45	63	320	1-1/4"

(1) Maximum working temperature for LPIC-01 and LPIC-02 models 135°C, for rest of models 155°C

(2) Maximum working pressure for LPIC-01 and LPIC-02 models 16 bar, for rest of models 25 bar

(3) Power defined according to: Primary 90/60°C and secondary 10/50°C

Optional: Other pressures, temperatures or fluids

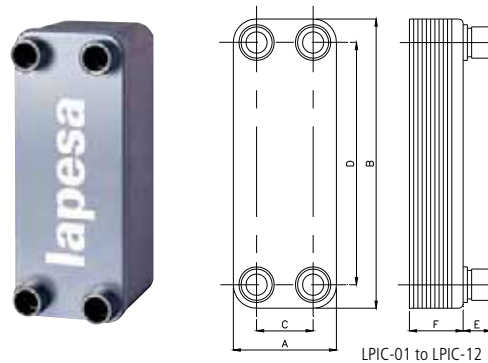

LPIC-01 to LPIC-12

DETTACHABLE PLATE EXCHANGERS		Ref.	Number of plates	Flow rate at 50°C (l/h)	Power (kW) ⁽³⁾	Pressure drop (meters H ₂ O)	A x C x F mm	E(max) mm	B mm	D mm	H mm	G mm
Max. working temperature	110°C	LPID-00	5	1.000	48	< 3	204 x 490 x 13,25	290	86	381	-	1-1/4"
Max. working pressure	10 bar	LPID-01	7	1.300	60	< 3	204 x 490 x 18,55	290	86	381	-	1-1/4"
Applications	Fluid/Fluid	LPID-02	11	2.600	120	< 3	204 x 490 x 29,15	290	86	381	-	1-1/4"
Chassis	Carbon steel	LPID-03	13	3.200	148	< 3	204 x 490 x 34,45	290	86	381	-	1-1/4"
Plates	AISI 316	LPID-04	17	4.200	195	< 3	204 x 490 x 45,05	290	86	381	-	1-1/4"
Connections	AISI 316	LPID-05	21	5.200	240	< 3	204 x 490 x 55,65	290	86	381	-	1-1/4"
Gaskets	EPDM	LPID-07	27	6.600	305	< 3	204 x 490 x 71,55	290	86	381	-	1-1/4"
Additional features	Thermal Insulation Support leg ⁽⁴⁾	LPID-10	37	8.600	400	< 3	204 x 490 x 98,05	290	86	381	-	1-1/4"
		LPID-12	45	10.000	465	< 3	204 x 490 x 119,25	290	86	381	-	1-1/4"
		LPID-21	23	15.700	725	< 3	312 x 963 x 80,5	960	140	690	185	2"
		LPID-22	29	20.500	950	< 3	312 x 963 x 101,5	960	140	690	185	2"
		LPID-23	35	25.000	1155	< 3	312 x 963 x 122,5	960	140	690	185	2"

(3) Power defined according to: Primary 90/60°C and secondary 10/50°C

(4) For models LPID-00 to LPID-12

Optional: Other pressures, temperatures or fluids

Chassis and plates in AISI-304, AISI-316 or Titanium

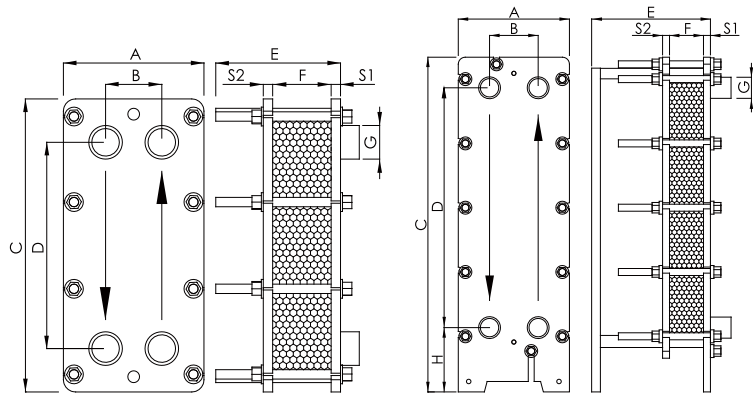

LPID-00 to LPID-12

LPID-21 to LPID-23

DATA REQUIRED TO PROVIDE A QUOTE FOR A CUSTOM PLATE EXCHANGER

To provide a specific offer of the most suitable plate heat exchanger for each particular case, the following details on the primary and secondary circuits are required:

- Primary and secondary circuit flows
- Input/output temperatures of the primary and secondary circuits
- Physical properties of the liquids (if they are neither water nor steam), density and specific heat.
- Required working pressure
- Pressure drop



CORAL VITRO - MASTER VITRO

Excellent surface protection!

VITREOUS ENAMELLING (protective surface treatment of steel): Vitreous enamelling for domestic hot water storage tanks is by far the most suitable lining of all those that exist on the market for this type of product made of carbon steel that requires special protection of the metal surfaces in contact with water.

MAXIMUM BONDING-MOLECULAR INTERACTION:

Applying a sophisticated "surface treatment" to the metal surface together with an automated process for the application of the enamel, results in much more than just a good mechanical adherence of the lining. During the curing process a **molecular interaction** occurs between the steel surface and the enamel coat applied.

This **maximum bonding** of the enamel coat to the steel surface and the high degree of **impermeability of the vitreous enamelling**, guarantee the **durability of the product** and prevents the kind of deterioration that can occur with other types of coatings, such as the detachment or blistering of the protective coat.

FOOD GRADE: Vitreous enamelling is a food-quality, impermeable lining with a porcelain look that protects the metal surface of the storage tank in contact with water.

All internal linings in DHW tanks must, by law, be "food grade" (Royal Decree 891/2006 and EC Regulation 1935/2004).

Our vitreous enamelling, in addition to food grade certification at the test temperature specified in current regulations (22°C), has **food grade certification at 120°C**, which guarantees its maximum quality at extreme working temperatures.

MAXIMUM WORKING TEMPERATURE: It withstands the maximum DHW storage temperatures that these types of installation (95°) handle, without any deterioration or detachment thanks to its capacity of molecular interaction with the steel surface.

This treatment is carried out by applying an enamel (inorganic chemical product) by either a "dry" or "wet" method (depending on the type of tank and its internal geometry), and then carrying out curing in an oven at 850°C.

DESIGN AND INTERNAL GEOMETRY: The design of our "CORAL VITRO" and "MASTER VITRO" storage tanks is based on the DIN/4753 T3 standard along with the company's own input based on **lapesa's** extensive experience in this type of product.

SPECIFIC DESIGN: Design mainly focused on guaranteeing the optimum end quality of the vitreous enamelling treatment applied to the internal metal surface in contact with DHW to prevent any cause of defects in the lining.

THREADED CONNECTIONS: Threaded connections to the tank in our vitreous enamelled tanks are external or male thread connections in order to totally protect the inner surface of the hydraulic connections in contact with DHW. A threaded bush with an internal or female thread could not be enamelled on its inner face as this is the thread face and part of the surface may be left unprotected and thus exposed to the effects of corrosion.

ANTI-LEGIONELLA DESIGN: Our "CORAL VITRO" and "MASTER VITRO" series of storage tanks with incorporated heat exchange systems are designed to prevent cold zones inside the storage tank and thus the possible proliferation of bacteria such as Legionella.



"CORAL VITRO" coil.



APPLICABLE DIRECTIVES AND STANDARDS:

Directive 2014/68/UE: European Pressure Equipment Directive.

Royal Decree 865/2003 that establishes hygiene-health criteria for the prevention and control of Legionnaires' disease.

Regulation on thermal installations in buildings (RITE) and its accompanying technical instructions.

UNE 100030:2005 IN STANDARD: Guide for the prevention and control of the proliferation and dissemination of legionella in installations.

UNE 112076:2004 IN STANDARD: Prevention of corrosion in water circuits.

APPLICATIONS

CORAL VITRO (80 TO 1500 LITRES):

- Individual installations for the production/storage of DHW
- Single-family homes
- Gymnasiums and sports centres
- Clinics and hospitals
- Laboratories
- Restaurants, cafeterias, bars
- Laundries
- Schools and universities
- Solar and other renewable energy installations
- DHW centralized systems (battery installation)

MASTER VITRO (1500 TO 6000 LITRES):

- Individual installations for production/storage with large DHW consumptions
- Collective housing
- Gymnasiums and sports centres
- Clinics and hospitals
- Laboratories
- Restaurants, cafeterias, bars
- Hotels
- Laundries
- Schools and universities
- Solar and other renewable energy installations
- Industrial installations (individual or battery installation)
- Large DHW consumptions (individual or battery installation)
- Centralized DHW systems in buildings (individual or battery installation)





CORAL VITRO - VITREOUS ENAMELLED STEEL

STORAGE models, energy savings!

Designed to provide maximum energy storage capacity, with overdimensioned rigid, mould-injected PU thermal insulation, these models maintain the DHW storage temperature for a long time without the need for any additional energy input, affording users continued savings throughout the life of the storage tank.

STORAGE TANKS: Designed to provide an extraordinary storage capacity that translates directly into real savings.

The overdimensioned, rigid, mould-injected PU thermal insulation maintains the DHW storage temperature over long periods of time without requiring additional energy input. This means less start-ups and adjustments of external energy sources, which in turn translates to less energy consumption.

Storage tanks without their own heat exchange system, ready for the installation of plate heat exchangers and/or electric immersion elements as the heating source.



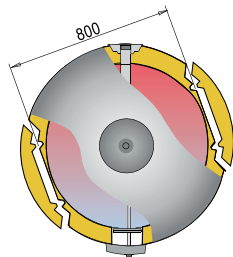
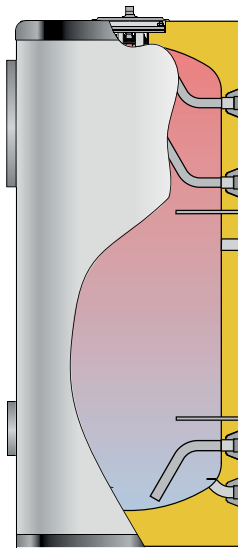

Detail of pre-cut insulation on 800 and 1000 litre tanks for access through 800 mm wide doors.

LONG-LASTING PRODUCT: VITREOUS ENAMELLED STEEL storage tank according to DIN 4753 T3: **Food grade impermeable** lining with a porcelain look that protects the metal surface of the storage tank in contact with water

EASY TO MAINTAIN: With access to tank interior through side and top holes, for inspection and cleaning. Models RB have a ND400 manhole on the side of the tank.

EASY TO INSTALL: Their dimensions facilitate access to enclosed spaces, even the models with capacities of 800 and 1000 litres, with a removable system for the insulation on the two opposite sides of the tank, allowing them access through 800 mm wide entrances.

CATHODIC PROTECTION: All of the CORAL VITRO models include cathodic protection which consists of magnesium anodes and an anode charge meter for control and maintenance purposes.

As an option these tanks can be fitted with "lapesa correx-up" permanent cathodic protection.

ELECTRIC HEATING: Ready to be fitted with Incoloy, low charge density electric immersion elements or with ceramic heating elements (see ELECTRIC HEATING chapter, page: 86)

MAXIMUM STORAGE CAPACITY: Extra thick, rigid, PU mould-injected insulation that minimizes heat losses of stored DHW (see HEAT INSULATION chapter, page: 89)

lapesa storage tanks have minimal heat losses and for this reason are considered to be one of the products with the greatest storage capacity on the market.



FEATURES COMMON TO ALL "CORAL VITRO" STORAGE MODELS:

- **VITREOUS ENAMELLED STEEL** DHW storage tanks according to **DIN 4753 T3**
- Capacities: **200, 300, 500, 800, 1000 and 1500 litres**
- Maximum working pressure of DHW storage tank: **8 bar** (10 bar optional)
- Maximum working temperature of DHW storage tank: **90 °C**
- Thermal insulation: **Rigid, mould-injected PU** (CFC/HCFC-free, 0.025 W/m²K)
- External lining: RAL 9016 WHITE padded PVC external lining with zip fastener, RAL 7045 GREY cover
- Cathodic protection: **Magnesium anodes** with anode **charge meter** on cover
- Tanks for VERTICAL installation on floor.

CORAL VITRO "R"

Tanks for DHW STORAGE. DHW production is by an external heat exchange system (plate heat exchanger) They can be fitted with immersion electric elements or ceramic electric elements. Tanks of 800 litre and 1000 litre capacities include an insulation system that allows access through 800 mm wide doors. Cathodic protection with magnesium anodes and anode charge meter.

Finish: RAL 9016 white padded external lining and RAL 7035 grey cover (1500 litre model - black cover)

EQUIPMENT: Control panel "T" with thermometer (except model CV1500R).

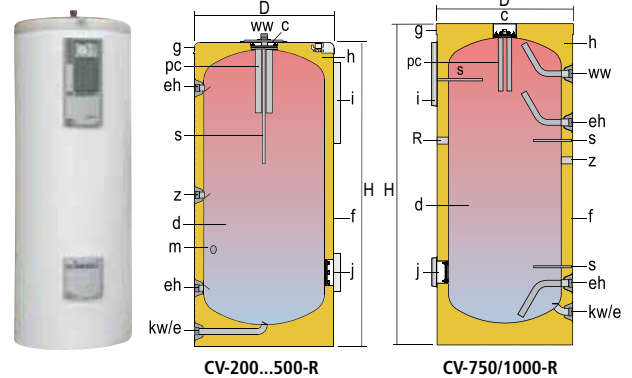

GENERAL CHARACTERISTICS		CV-200-R	CV-300-R	CV-500-R	CV-800-R	CV-1000-R	CV-1500-R
DHW capacity	l.	200	300	500	800	1000	1500
D: external diameter	mm.	620	620	770	950	950	1160
H: overall height	mm.	1205	1685	1690	1840	2250	2320
kw/e: cold water inlet / drain	" GAS/M	1	1	1	1 1/4	1 1/4	1 1/2
ww: DHW outlet	" GAS/M	1	1	1	1 1/2	1 1/2	1 1/2
z: recirculation	" GAS	1 1/4 M	1 1/4 M	1 1/4 M	1 1/2 H	1 1/2 H	1 1/2 M
m: Probe tube connection for sensors	" GAS/M	3/4	3/4	3/4	-	-	3/4
eh: plate exchanger connection	" GAS/M	1 1/4	1 1/4	1 1/4	1 1/2	1 1/2	2
R: side connection	" GAS	-	-	-	1 1/2 H	1 1/2 H	2M
Empty weight (approx.)	Kg	70	90	130	170	200	343

c - Top inspection hole
d - DHW tank
f - Outer lining
g - Cover
h - Thermal insulation
i - Control panel
j - Inspection hole
s - Probe tube for sensors
pc - Cathodic protection anode
e - Drain

CORAL VITRO "RB"

Tanks for DHW STORAGE. DHW production is by an external heat exchange system (plate heat exchanger) The "RB" models include a **ND 400 side manhole**. They can be fitted with immersion electric elements or ceramic electric elements. Tanks with a capacity of 800 and 1000 litres include an insulation system that allows access through 800 mm wide doors.

Cathodic protection with magnesium anodes and anode charge meter.

Finish: RAL 9016 white padded external lining and RAL 7035 grey cover (1500 litre model - black cover)

EQUIPMENT:

Control panel "T" with thermometer (except model CV1500RB).

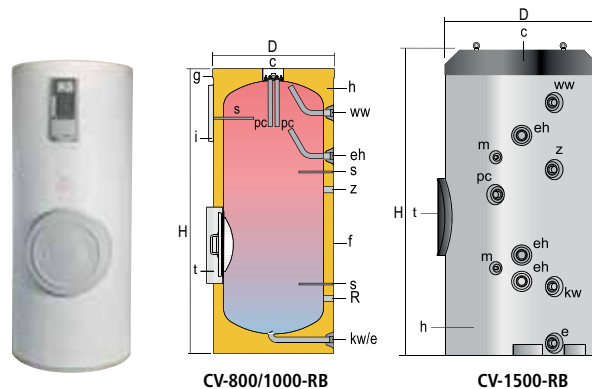

c - Top inspection hole
d - DHW tank
f - Outer lining
g - Cover
h - Thermal insulation
i - Control panel
j - Side hole ND400
s - Probe tube for sensors
pc - Cathodic protection anode
e - Drain

GENERAL CHARACTERISTICS		CV-800-RB	CV-1000-RB	CV-1500-RB
DHW capacity	l.	800	1000	1500
D: external diameter	mm.	950	950	1160
H: overall height	mm.	1840	2250	2320
kw/e: cold water inlet / drain	" GAS/M	1 1/4	1 1/4	1 1/2
ww: DHW outlet	" GAS/M	1 1/2	1 1/2	1 1/2
z: recirculation	" GAS	1 1/2 F	1 1/2 F	1 1/2 M
m: Probe tube connection for sensors	" GAS/M	-	-	3/4
eh: plate exchanger connection	" GAS/M	1 1/2	1 1/2	2
R: side connection	" GAS/F	1 1/2	1 1/2	-
Side manhole	ND mm.	ND400	ND400	ND400
Empty weight (approx.)	Kg	170	230	373

CORAL VITRO

*Service, comfort and savings,
with the best quality-price ratio.*



lapesa
Solutions



CORAL VITRO - VITREOUS ENAMELLED STEEL

Models with COIL, production and efficiency!

Tanks with high-efficiency, internal heat exchange coils for high DHW production demands at peak flow. Their overdimensioned, rigid, mould-injected PU thermal insulation maintains DHW storage temperature for long periods without the need for any additional energy input, providing users with continued savings throughout the life of the storage tank.



STORAGE TANKS WITH COIL: Tanks with high-efficiency, internal heat exchange coils for high DHW production demands at peak flow.

Models with one or two coils for the production of DHW using one or two energy sources, with the option of adding backup electric heating elements. Overdimensioned, rigid, mould-injected PU thermal insulation maintains the DHW storage temperature over long periods of time without requiring additional energy input. This means less start-ups and adjustments of external energy sources, which translates to energy savings.

LONG-LASTING PRODUCT: VITREOUS ENAMELLED STEEL storage tank according to **DIN 4753 T3** Food grade impermeable lining with a porcelain look that protects the metal surface of the storage tank in contact with water

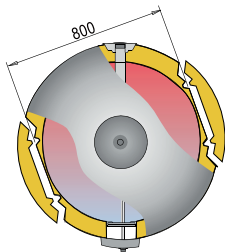
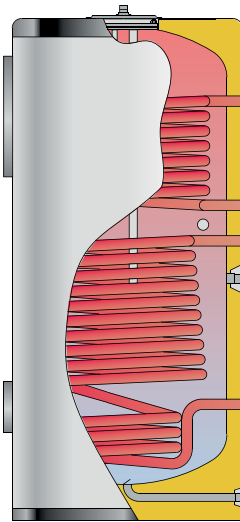

Detail of pre-cut insulation on 800 and 1000 litre tanks for access through 800 mm wide doors.

ANTI-LEGIONELLA DESIGN: High-efficiency coils designed to heat from the lowest zone in the storage tank preventing cold storage zones inside the tank and thus the possibility of the proliferation of bacteria such as Legionella.

EASY TO MAINTAIN: With access to tank interior through side and top ports, for inspection and cleaning. In models M1B/M2B there is a ND400 manhole on the side of the tank.

EASY TO INSTALL: Their dimensions facilitate access to enclosed spaces, even the models with capacities of 800 and 1000 litres, with a detachable system for the insulation on the two opposite sides of the tank, allowing access through 800 mm wide entrances.

ELECTRIC HEATING: Ready to be fitted with Incoloy, low charge density electric immersion elements or with ceramic heating elements, with integrated control and regulation units. (See ELECTRIC HEATING chapter, page: 86).

MAXIMUM STORAGE CAPACITY: Extra thick, rigid, PU mould-injected insulation that minimizes heat losses of stored DHW (see HEAT INSULATION chapter, page: 89).

lapesa storage tanks have minimal heat losses and for this reason are considered to be one of the products with the greatest storage capacity on the market.



FEATURES COMMON TO ALL "CORAL VITRO" COIL MODELS:

- **VITREOUS ENAMELLED STEEL** DHW storage tank according to **DIN 4753 T3**
- Capacities: **200, 300, 500, 800, 1000 and 1500 litres**
- Maximum working pressure of DHW storage tank: **8 bar** (10 bar optional)
- Maximum working pressure of coil/s: **25 bar**
- Maximum working temperature of DHW storage tank: **90 °C**
- Maximum working temperature of coil/s: **200 °C**
- Thermal insulation: **Rigid, mould-injected PU** (CFC/HCFC-free, 0.025 W/m²K)
- External lining: RAL 9016 WHITE padded PVC external lining with zip fastener, RAL 7035 GREY cover
- Cathodic protection: **Magnesium anodes** with anode charge meter on cover
- Tanks for VERTICAL installation on floor.

CORAL VITRO "M1S"

Storage tanks with **"ONE COIL"** for the production of DHW using an external energy source.
 Specially designed for **DISTRIBUTED SOLAR ENERGY** installations.
 With sheath incorporated for backup ceramic electric heating element.
 Cathodic protection with magnesium anode and anode charge meter.
 Finish: RAL 9016 padded external lining and RAL 7035 grey cover.
 Designed for wall mounting for models up to 150 litres capacity.

OPTIONAL EQUIPMENT:

KIT: ceramic heating element with dual control and safety thermostat for backup electric heating.
 Brackets for wall mounting, up to model CV-150-M1S.

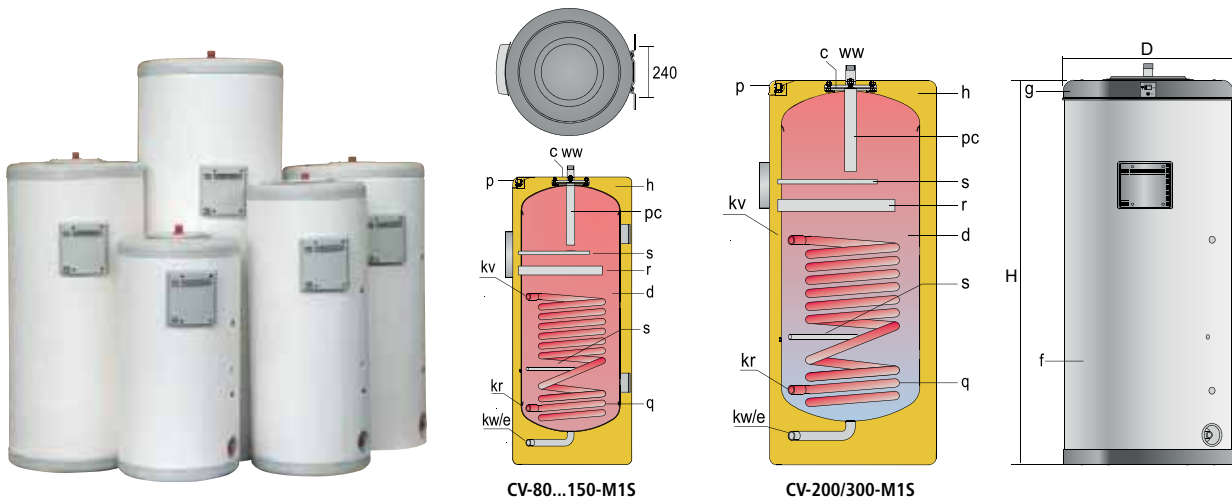

GENERAL CHARACTERISTICS		CV-80-M1S	CV-110-M1S	CV-150-M1S	CV-200-M1S	CV-300-M1S
DHW capacity	l.	80	110	150	200	300
D: external diameter	mm.	480	480	560	620	620
H: overall height	mm.	935	1155	1265	1205	1685
kw/e: cold water inlet / drain	" GAS/M	3/4	3/4	3/4	1	1
ww: DHW outlet	" GAS/M	3/4	3/4	3/4	1	1
kv: primary input	" GAS/F	1/2	1/2	1/2	1/2	1/2
kr: primary return	" GAS/F	1/2	1/2	1/2	1/2	1/2
Heating coil surface	m ²	0,3	0,5	0,6	0,8	1,3
Empty weight (approx.)	Kg	43	51	65	72	91

c - Top inspection hole
 d - DHW tank
 f - Outer lining
 g - Cover
 q - Heating coil
 h - Thermal insulation
 s - Probe tube for sensors
 r - Electric element sheath
 p - Anode meter
 pc- Cathodic protection anode

CORAL VITRO "M1M" **NEW**

Storage tanks with **ONE COIL** for the production of DHW using an external energy source, such as a boiler or solar panels. **ONLY WALL MOUNTING INSTALLATION**, with connections on the lower part. Cathodic protection with magnesium anode and anode charge meter. Finish: RAL 9016 padded external lining and RAL 7035 grey cover.

EQUIPAMIENTO OPCIONAL:

Immersion electric heating element, 1500 W, with dual control and safety thermostat for backup electric heating.

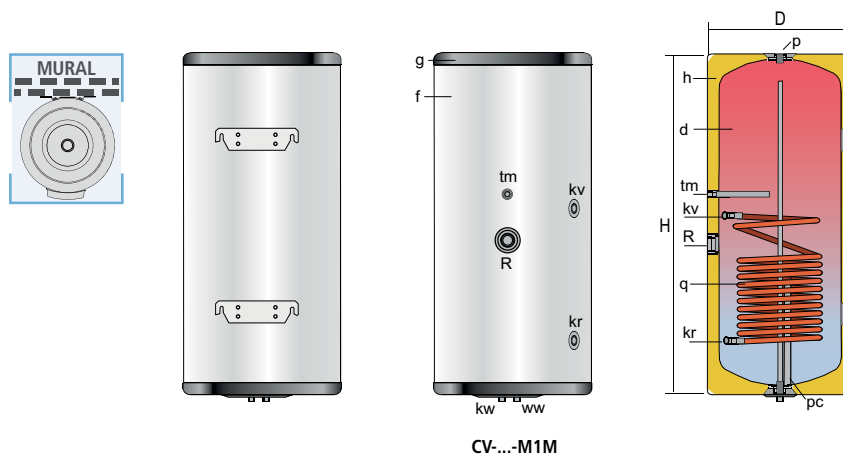

CV...-M1M

CARACTERÍSTICAS GENERALES		CV-90-M1M	CV-120-M1M	CV-160-M1M
DHW capacity	l.	90	110	150
D: external diameter	mm.	480	480	560
H: overall height	mm.	850	1155	1095
kw: cold water inlet / drain	" GAS/M	3/4	3/4	3/4
ww: DHW outlet	" GAS/M	3/4	3/4	3/4
kv: primary input	" GAS/H	1/2	1/2	1/2
kr: primary return	" GAS/H	1/2	1/2	1/2
R: connexion for electric heating element	" GAS/H	1-1/2	1-1/2	1-1/2
Heating coil surface	m ²	0,3	0,6	0,8
Empty weight (approx.)	Kg	43	51	65

- c - Top inspection hole
- d - DHW tank
- f - Outer lining
- g - Cover
- h - Thermal insulation
- p - Drain connexion
- pc - Cathodic protection anode
- q - Coil
- R - Electric element connexion
- tm - Probe tube for sensors

CORAL VITRO "M1"

Storage tanks with **"ONE COIL"** for the production of DHW using an external energy source (boiler, solar panels, heat pump, etc.).

They can be fitted with immersion electric elements or ceramic electric elements.

800 and 1000 litre capacity tanks include an insulation system that allows them to pass through 800 mm wide doors.

"M1B" models with ND400 side manhole.

Vertical WALL installation up to the 150 liter model.

Cathodic protection with magnesium anodes and anode tester (CV-110 ... 500-M1), or with direct contact magnesium anodes (CV-800 ... 1500-M1 / M1B).

Finishing consisting of a white RAL 9016 jacket and a gray RAL 7035 top cover fitted at the factory (except CV1500M1B model fitted with gray RAL 7042 jacket delivered separately).

Optionally, immersion or ceramic electrical heating elements (see p. 86) regulated by means of a control panel for the capacities below 1,000 liters (see p. 88) or a double thermostat for the CV1500M1B (see p. 74).

EQUIPMENT:

Thermometer in "TS" side panel (except models CV1500M1 and CV1500M1B).

Brackets for wall mounting, up to model CV-150-M1

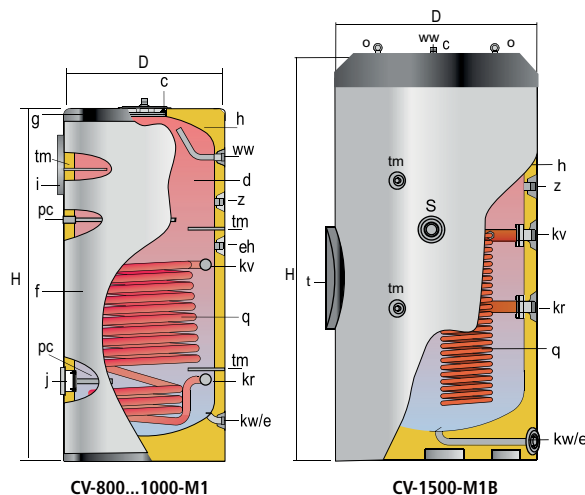

- c - Top inspection hole
- d - DHW tank
- kw/e - Cold water inlet / drain
- eh - Side connection
- f - Outer lining
- g - Cover
- h - Thermal insulation
- i - Control panel
- j - Inspection hole
- o - Lifting eyes
- pc - Cathodic protection anode
- q - Heating coil
- t - Side manhole ND400
- tm - Probe tube connection for sensors

GENERAL CHARACTERISTICS		CV	CV	CV	CV	CV	CV	CV	CV	CV	CV	CV
		110-M1	150-M1	200-M1	300-M1	500-M1	800-M1	1000-M1	1500-M1	800-M1B	1000-M1B	1500-M1B
DHW capacity	l.	110	150	200	300	500	800	1000	1500	800	1000	1500
D: external diameter	mm.	480	560	620	620	770	950	950	1160	950	950	1160
H: overall height	mm.	1155	1265	1205	1685	1690	1840	2250	2320	1840	2250	2320
kw/e: cold water inlet / drain	" GAS/M	3/4	3/4	1	1	1	1 1/4	1 1/4	1 1/2	1 1/4	1 1/4	1 1/2
ww: DHW outlet	" GAS/M	3/4	3/4	1	1	1	1 1/2	1 1/2	1 1/2	1 1/2	1 1/2	1 1/2
z: recirculation	" GAS/M	-	-	1	1	1	1 1/2	1 1/2	1 1/2	1 1/2	1 1/2	1 1/2
eh: side connection	" GAS	-	-	-	2 M	2 M	1 1/2 H	1 1/2 H	2 M	1 1/2 H	1 1/2 H	2 M
kv: primary input	" GAS/F	1/2	1/2	1	1	1	1	1	1	1	1	1
kr: primary return	" GAS/F	1/2	1/2	1	1	1	1	1	1	1	1	1
Heating coil surface	m ²	0,6	0,8	1,4	1,8	2,0	2,7	3,3	4,0	2,7	3,3	4,0
Side manhole	ND mm.	-	-	-	-	-	-	-	-	ND400	ND400	ND400
Empty weight (approx.)	Kg	55	66	85	115	160	195	230	394	225	260	424

CORAL VITRO "M2"

Storage tanks with **"TWO COILS"** for the production of DHW using two combined external energy sources (boiler, solar panels, heat pump, etc.).

They can be fitted with immersion electric elements or ceramic electric elements.

The 800 and 1000 litre capacity tanks include an insulation system that allows them to pass through 800 mm wide doors. "M2B" models with ND400 side manhole.

Cathodic protection with magnesium anodes and anode tester (CV-300 ... 500-M2), or with direct contact magnesium anodes (CV-800 ... 1000-M2 / M2B).

Finishing consisting of a white RAL 9016 jacket and a gray RAL 7035 top cover fitted at the factory.

Optionally, immersion or ceramic electrical heating elements (see p. 86) regulated by means of a control panel for the capacities below 1,000 liters (see p. 88).

EQUIPMENT:

Thermometer in "TS" side panel (except models CV1500M2 and CV1500M2B).

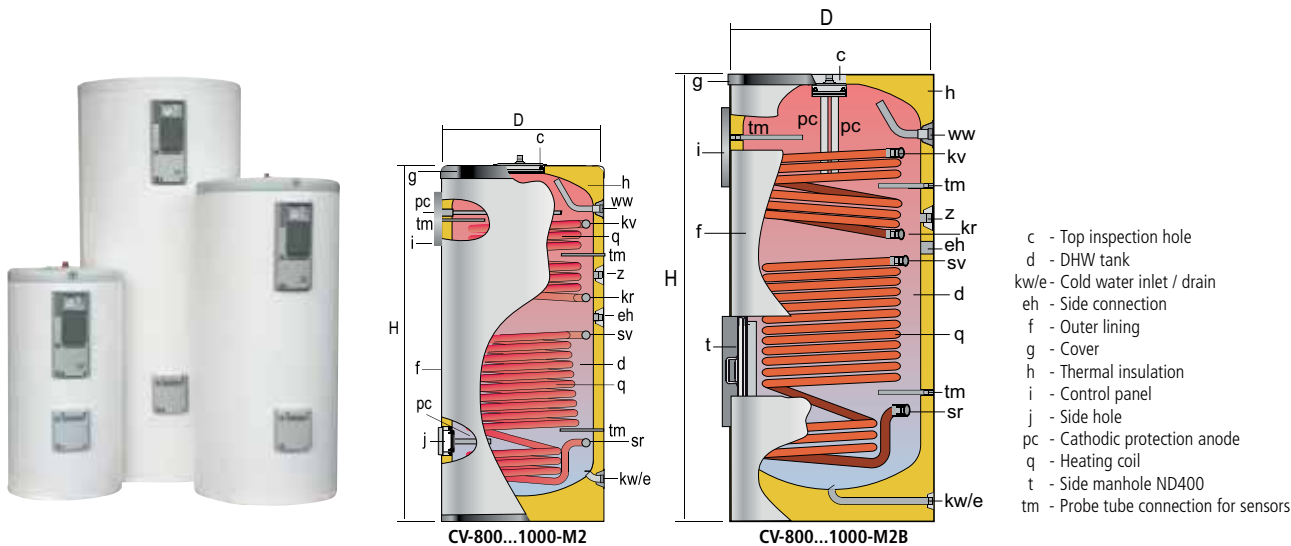

- c - Top inspection hole
- d - DHW tank
- kw/e - Cold water inlet / drain
- eh - Side connection
- f - Outer lining
- g - Cover
- h - Thermal insulation
- i - Control panel
- j - Side hole
- pc - Cathodic protection anode
- q - Heating coil
- t - Side manhole ND400
- tm - Probe tube connection for sensors

GENERAL CHARACTERISTICS		CV-300-M2	CV-400-M2	CV-500-M2	CV-800-M2	CV-1000-M2	CV-1500-M2	CV-800-M2B	CV-1000-M2B	CV-1500-M2B
DHW capacity	l.	300	400	500	800	1000	1500	800	1000	1500
D: external diameter	mm.	620	770	770	950	950	1160	950	950	1160
H: overall height	mm.	1685	1475	1690	1840	2250	2320	1840	2250	2320
kw/e: cold water inlet / drain	" GAS/M	1	1	1	1 1/4	1 1/4	1 1/2	1 1/4	1 1/4	1 1/2
ww: DHW outlet	" GAS/M	1	1	1	1 1/2	1 1/2	1 1/2	1 1/2	1 1/2	2
z: recirculation	" GAS/M	1	1	1	1 1/2	1 1/2	1 1/2	1 1/2	1 1/2	3/4
eh: side connection	" GAS	2 M	2 M	2 M	1 1/2 H	1 1/2 H	2 M	1 1/2 H	1 1/2 H	2M
kv, kr: upper coil connections	" GAS/F	1	1	1	1	1	1	1	1	1
sv, sr: lower coil connections	" GAS/F	1	1	1	1	1	1	1	1	1
Lower coil heating surface	m ²	1,8	1,5	2,0	2,7	3,3	4,0	2,7	3,3	3,4
Upper coil heating surface	m ³	0,7	0,7	1,2	1,3	1,3	1,3	1,3	1,3	1,3
Side manhole	ND mm.	-	-	-	-	-	-	ND400	ND400	ND400
Empty weight (approx.)	Kg	120	150	175	213	249	415	243	279	445

CORAL VITRO "HL"

Storage tanks with **ONE HIGH-PERFORMANCE COIL**, with a large heat exchange surface area for the production of DHW by means of low-temperature energy sources such as heat pumps or solar collectors with low solar radiation.

They can be equipped with flanged immersion electric heating elements in the side hole.

800 and 1000 litre capacity tanks include an insulation system that allows them to pass through 800 mm wide doors.

"HLB" models with ND400 side manhole.

Cathodic protection with magnesium anodes and anode charge meter.

Finish: RAL 9016 white padded external lining and RAL 7035 grey cover.

EQUIPMENT:

Thermometer in "TS" side panel..

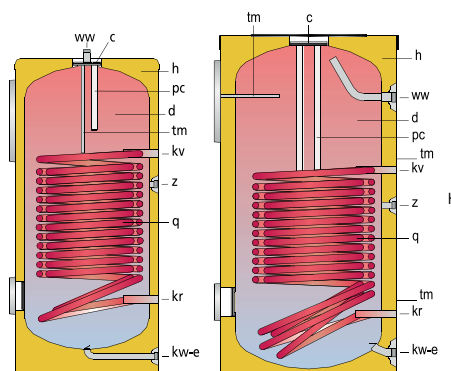

- c - Top inspection hole
- d - DHW tank
- f - Outer lining
- g - Cover
- h - Thermal insulation
- i - Control panel
- j - Side hole
- q - High performance heating coil
- tm- Probe tube connection for sensors
- pc- Cathodic protection anode

GENERAL CHARACTERISTICS		CV-200-HL	CV-300-HL	CV-400-HL	CV-500-HL	CV-750-HL	CV-1000-HL	CV-800-HLB	CV-1000-HLB
DHW capacity	l.	200	300	400	500	750	1000	800	1000
D: external diameter	mm.	620	620	770	770	950	950	950	950
H: overall height	mm.	1205	1685	1475	1690	1840	2250	1840	2250
kw/e: cold water inlet / drain	" GAS/M	1	1	1	1	1 1/4	1 1/4	1 1/4	1 1/4
ww: DHW outlet	" GAS/M	1	1	1	1	1 1/2	1 1/2	1 1/2	1 1/2
z: recirculation	" GAS/M	1	1	1	1	1 1/2	1 1/2	1 1/2	1 1/2
kv: primary input	" GAS/F	1	1	1	1	1	1	1	1
kr: primary return	" GAS/F	1	1	1	1	1	1	1	1
Heating coil surface	m ²	2,4	3,1	4,8	4,8	5,7	6,1	5,7	6,1
Side manhole	ND mm.	-	-	-	-	-	-	ND 400	ND 400
Empty weight (approx.)	Kg	100	130	185	195	270	310	300	345

CORAL VITRO "HL-DUO" **NEW**

Storage tanks with **TWO HIGH PERFORMANCE COILS** for the production of DHW using two combined external low temperature energy sources solar panel and heat pump.

Cathodic protection with magnesium anodes and anode charge meter.

Finish: RAL 9016 white padded external lining and RAL 7035 grey cover.

EQUIPMENT:

They can be equipped with an immersion threaded electrical heating element.

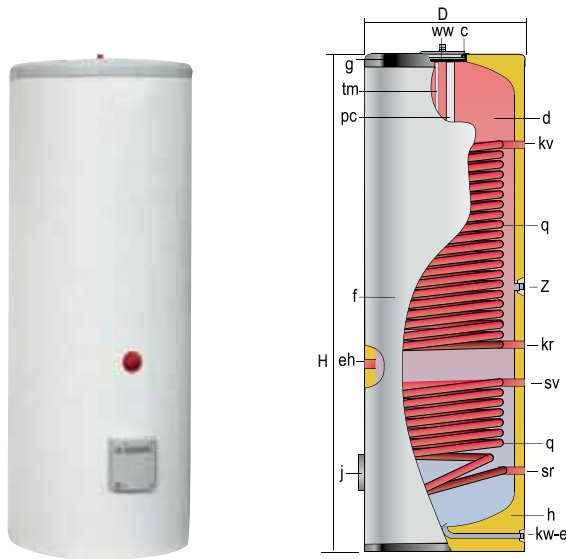

CV-350HL/DUO

- c - Top inspection hole
- d - DHW tank
- f - Outer lining
- g - Cover
- h - Thermal insulation
- j - Side hole
- q - High performance heating coil
- tm- Probe tube connection for sensors
- pc- Cathodic protection anode

GENERAL CHARACTERISTICS		CV-350 HL/DUO
DHW capacity	l.	350
D: external diameter	mm.	620
H: overall height	mm.	1935
kw: cold water inlet / drain	" GAS/M	1
ww: DHW outlet	" GAS/M	1
z: recirculation	" GAS/M	1
eh: side connection	" GAS/F	1 1/2
kv: primary input	" GAS/F	1
kr: primary return	" GAS/F	1
Heating coil surface	m ²	1.3
Upper coil heating surface	m ²	3.5
Empty weight (approx.)	Kg	164



CORAL VITRO - VITREOUS ENAMELLED STEEL

DOUBLE-WALL models, multifunctional storage tanks!

The water contained in the surrounding or primary tank is heated by an external energy source (boiler, heat pump, solar collectors, etc.) that passes through this vessel and transmits its thermal energy to the water contained in the inner tank or DHW storage tank.

DOUBLE-WALL TANKS: The DOUBLE-WALL system basically consists of a combination of two tanks, one inside the other. DHW production takes place by the exchange of heat from the external or primary tank to the internal or secondary tank (DHW), through the tank's entire surface.

The water contained in the surrounding or primary tank is heated by an external energy source (boiler, heat pump, solar collectors, etc.) that passes through this vessel or through the solar coil and transmits its thermal energy to the water contained in the inner tank or DHW storage tank.

LONG-LASTING PRODUCT: VITREOUS ENAMELLED STEEL storage tank according to **DIN 4753 T3**. Food grade impermeable lining with a porcelain look that protects the metal surface of the storage tank in contact with water.

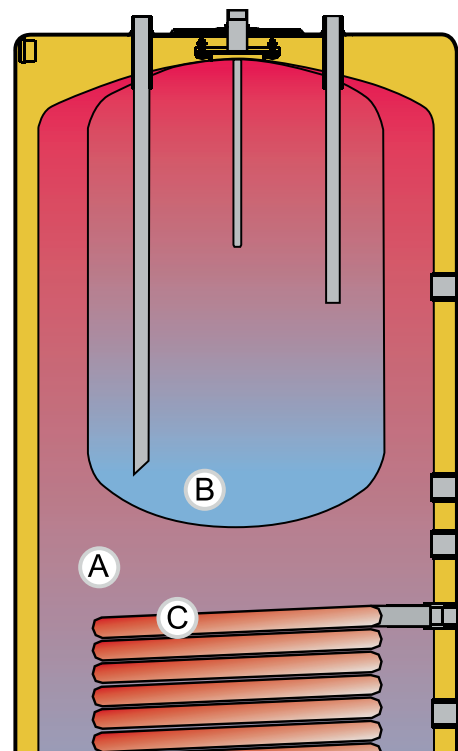

(A) BUFFER TANK. (B) DHW TANK. (C) SOLAR COIL.

DHW PRODUCTION/STORAGE TANKS CORAL VITRO - **DOUBLE WALL**

lapesa

MULTIFUNCTIONAL: Multifunctional design allowing several energy sources to be combined at the same time. Large thermal energy storage capacity in primary heating circuit as an inertia buffer. An electric heating element can be incorporated in the primary circuit (surrounding tank), which is free of limescale or corrosion.

INERTIA BUFFER + DHW STORAGE TANK: The combination of an inertia buffer and DHW double wall production/storage tank in one single product. Ideal for installations with HEAT PUMPS, BIOMASS BOILERS OR SOLAR COLLECTORS, or the combination of several energy sources.

ANTI-LEGIONELLA DESIGN: Totally uniform DHW storage temperature, with no cold zones inside the

storage tank. The surround heating of the DHW produces a uniform water storage temperature throughout the whole of the tank, which in turn allows it to be used to its full capacity.

EASY TO INSTALL: Their dimensions facilitate access to enclosed spaces (even the models with capacities greater than 800 litres), with a detachable system for the insulation on the two opposite sides of the tank, allowing them access through 800 mm wide entrances.

MAXIMUM STORAGE CAPACITY: Extra thick, rigid, PU mould-injected insulation that minimizes heat losses of stored DHW (see HEAT INSULATION chapter, page: 89)



FEATURES COMMON TO ALL "CORAL VITRO" DOUBLE WALL MODELS:

- **VITREOUS ENAMELLED STEEL** DHW storage tank according to **DIN 4753 T3**
- Capacities: **600/150, 800/150 and 1000/200 litres**
- Maximum working pressure of DHW storage tank: **8 bar** (10 bar optional)
- Maximum working temperature of DHW storage tank: **90 °C**
- Maximum working pressure of surrounding tank (primary circuit): **3 bar**
- Maximum working temperature of surrounding tank (primary circuit): **110 °C**
- Thermal insulation: **Rigid, mould-injected PU** (CFC/HCFC-free, 0.025 W/m²K)
- External lining: RAL 9016 WHITE padded PVC external lining with zip fastener, RAL 7045 GREY cover
- Cathodic protection: **Magnesium anodes** with anode charge meter on cover
- Tanks for VERTICAL installation on floor.

CORAL VITRO "P"

"DOUBLE-WALL" tanks termed **"MULTIFUNCTIONAL"** are known as such because several different energy sources can be installed for one single tank.

The production of DHW is carried out by heat exchange between the primary (external) circuit and the DHW (internal) tank via several external energy sources (boiler, solar panels, heat pump, electric heating element, etc.) simultaneously coupled to the tank.

These tanks have a large capacity primary circuit acting as a thermal inertia buffer (for solid fuel or biomass boilers and/or heat pump), which houses a coil with a large heat exchange surface, specially designed for solar energy.

The DHW tank is equipped with cathodic protection with magnesium anodes.

Prepared for the installation of an electric heating element in the primary circuit.

Finish: RAL 9016 padded external lining and RAL 7035 grey covers.

EQUIPMENT:

"TS" panel with DHW thermometer.

OPTIONAL: "TD", "TPA" control panels (see REGULATION AND CONTROL chapter, page: 88).

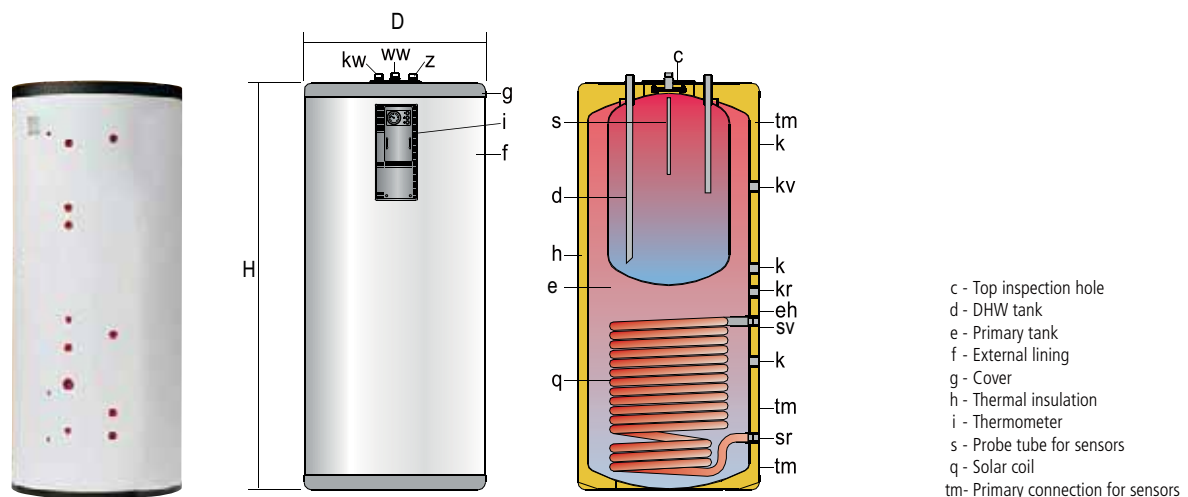

- c - Top inspection hole
- d - DHW tank
- e - Primary tank
- f - External lining
- g - Cover
- h - Thermal insulation
- i - Thermometer
- s - Probe tube for sensors
- q - Solar coil
- tm - Primary connection for sensors

GENERAL CHARACTERISTICS		CV-600-P	CV-800-P	CV-1000-P
Total capacity	l.	580	773	970
DHW capacity	l.	150	150	200
Primary HW capacity	l.	430	623	770
D: external diameter	mm.	770	950	950
H: overall height	mm.	1730	1840	2250
kw: cold water inlet	" GAS/M	1	1	1
ww: DHW outlet	" GAS/M	1	1	1
z: recirculation	" GAS/M	1	1	1
kv: primary input	" GAS/F	1 1/4	1 1/4	1 1/4
kr: primary return	" GAS/F	1 1/4	1 1/4	1 1/4
sv: coil inlet	" GAS/F	1	1	1
sv: coil return	" GAS/F	1	1	1
eh: side connection	" GAS/F	2	2	2
k: side connection	" GAS/F	1 1/4	1 1/4	1 1/4
tm: probe tube connection for sensors	" GAS/F	1/2	1/2	1/2
Coil surface	m ²	2,4	2,7	2,7
Control panel	model	TS	TS	TS
Empty weight (approx.)	Kg	170	260	290

CORAL VITRO "P/DUO" **NEW**

DOUBLE-WALL tanks termed **MULTIFUNCTIONAL** are known as such because several different energy sources can be installed on one single tank.

The production of DHW is carried out by heat exchange between the primary (external) circuit and the DHW (internal) tank via several external energy sources (boiler, solar panels, heat pump, electric heating element, etc.) simultaneously coupled to the tank.

These tanks have a large capacity primary circuit acting as a thermal inertia buffer (for solid fuel or biomass boilers and/or heat pump), which houses a coil with a large heat exchange surface, specially designed for solar energy.

The DHW tank is equipped with cathodic protection with magnesium anodes.

Prepared for the installation of an electric heating element in the primary circuit.

Finish: RAL 9016 padded external lining and RAL 7035 grey covers.

EQUIPMENT:

"T" panel with DHW thermometer.

OPTIONAL: "TD", "TPA", "TBC" control panels (see REGULATION AND CONTROL chapter, page: 88).

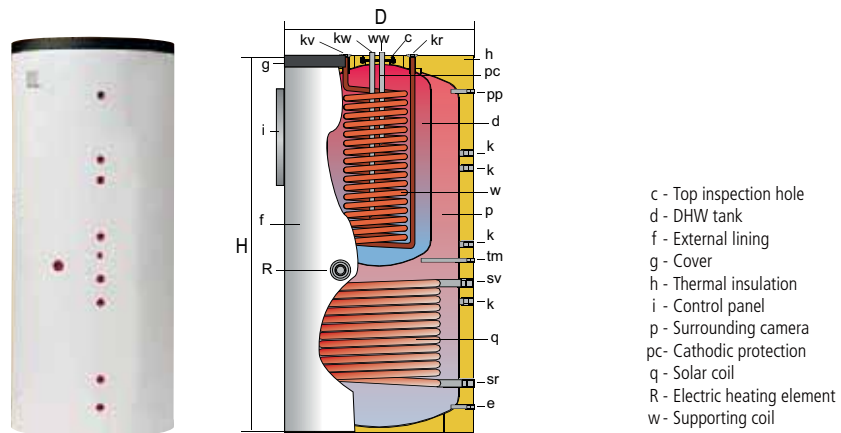

- c - Top inspection hole
- d - DHW tank
- f - External lining
- g - Cover
- h - Thermal insulation
- i - Control panel
- p - Surrounding camera
- pc - Cathodic protection
- q - Solar coil
- R - Electric heating element
- w - Supporting coil

GENERAL CHARACTERISTICS		CV-800-P/DUO	CV-1000-P/DUO
Total capacity	l.	765	991
DHW capacity	l.	176	228
Surrounding tank capacity	l.	589	657
D: external diameter	mm.	950	950
H: overall height	mm.	1840	2250
kw: cold water inlet / drain	" GAS/M	1"	1"
ww: DHW outlet	" GAS/M	1"	1"
kv: primary input	" GAS/F	1"	1"
kr: primary return	" GAS/F	1"	1"
sv: coil inlet	" GAS/F	1"	1"
sr: coil outlet	" GAS/F	1"	1"
R: side connexion	" GAS/F	1-1/2"	1-1/2"
e: drain	" GAS/F	1/2"	1/2"
k: side connection	" GAS/F	1"	1"
pp: purge	" GAS/F	1/2"	1/2"
tm: sensor connexion	mm	Ø int 10 x 285	Ø int 10 x 285
Heating lower coil surface	m ²	2,4	2,4
Heating upper coil surface	m ²	1,3	1,3
Control panel	modelo	T	T
Empty weight (approx.)	Kg	260	290

CORAL VITRO - COIL, models M1 y M2 [Continuous flow DHW production (liters/hour) 10°C - 45°C]

PRIMARY INPUT TEMPERATURE °C		55 °C		70 °C		80 °C		90 °C	
tank model	primary pump flow (m³/h)	KW	DHW (l/h)	KW	DHW (l/h)	KW	DHW (l/h)	KW	DHW (l/h)
CV-110-M1	2	9	221	18	443	27	664	33	812
	3	10	246	21	517	29	714	36	886
	5	11	271	23	566	33	812	40	984
CV-150-M1	2	11	271	22	541	30	738	37	910
	3	12	295	24	591	32	787	40	984
	5	13	320	27	664	36	886	44	1083
CV-200-M1	2	14	344	29	714	39	960	48	1181
	3	15	369	33	812	44	1083	54	1329
	5	17	418	38	935	50	1230	62	1526
CV-300-M1/M2 * * lower coil	2	17	418	34	837	45	1107	57	1403
	4	19	468	43	1058	56	1378	70	1722
	6	21	517	48	1181	63	1550	77	1895
CV-400-M1/M2 * * lower coil	2	16	394	33	812	44	1083	55	1353
	4	19	468	42	1033	55	1353	67	1649
	6	20	492	47	1157	61	1501	75	1846
CV-500-M1/M2 * * lower coil	2	18	443	37	910	48	1181	61	1501
	4	21	517	47	1157	61	1501	75	1846
	6	23	566	52	1280	69	1698	84	2067
CV-800-M1/M2 * * lower coil	3	31	763	55	1353	71	1747	86	2116
	5	36	886	65	1599	83	2042	102	2510
	8	41	1009	73	1796	95	2338	116	2854
CV-1000-M1/M2 * * lower coil	3	35	861	64	1575	81	1993	98	2411
	5	42	1033	74	1821	96	2362	116	2854
	8	48	1181	84	2067	109	2682	133	3273
CV-1500-M1/M2 * lower coil	3	40	984	72	1772	94	2313	116	2854
	5	48	1181	85	2092	112	2756	138	3396
	8	55	1353	97	2387	129	3174	158	3888
CV-300/400-M2 ** * upper coil	2	9	221	19	468	25	615	32	787
	4	11	271	23	566	31	763	39	960
	6	12	295	25	615	34	837	43	1058
CV-500-M2 ** * upper coil	2	13	320	27	664	35	861	45	1107
	4	15	369	32	787	42	1033	54	1329
	6	17	418	36	886	47	1157	60	1476
CV-800/1000-M2 ** * upper coil	2	14	344	29	714	39	960	48	1181
	4	16	394	36	886	47	1157	58	1427
	6	17	418	40	984	52	1280	65	1599
CV-1500-M2 ** * upper coil	2	14	344	29	714	39	960	48	1181
	4	16	394	36	886	47	1157	58	1427
	6	17	418	40	984	52	1280	65	1599

CORAL VITRO - COIL, models M1S [Continuous flow DHW production (liters/hour) 10°C - 45°C]

PRIMARY INPUT TEMPERATURE °C		55 °C		60 °C		70 °C		80 °C	
tank model	primary pump flow (m³/h)	KW	DHW (l/h)	KW	DHW (l/h)	KW	DHW (l/h)	KW	DHW (l/h)
CV-80-M1S	0,2	3	74	4	98	5	123	7	172
	0,6	5	123	6	148	8	197	10	246
	1	6	148	7	172	10	246	12	295
CV-110-M1S	0,2	4	98	5	123	7	172	9	221
	0,6	6	148	8	197	11	271	15	369
	1	7	172	10	246	13	320	18	443
CV-150-M1S	0,2	4	98	6	148	8	197	10	246
	0,6	7	172	9	221	12	295	18	443
	1	8	197	11	271	15	369	21	517
CV-200-M1S	0,4	7	172	9	221	13	320	18	443
	1	10	246	12	295	18	443	25	615
	1,5	11	271	14	344	20	492	28	689
CV-300-M1S	0,4	9	221	12	295	16	394	21	517
	1	13	320	17	418	24	591	31	763
	1,5	15	369	20	492	27	664	36	886

NOTE: for further information, consult our technical product catalog.

CORAL VITRO - COIL, models M1 y M2 [Continuous flow DHW production (liters/hour) 10°C - 60°C]

PRIMARY INPUT TEMPERATURE °C		70 °C		80 °C		90 °C	
tank model	primary pump flow (m³/h)	KW	DHW (l/h)	KW	DHW (l/h)	KW	DHW (l/h)
CV-110-M1	2	13	224	22	379	28	482
	3	15	258	24	413	30	517
	5	16	276	26	448	33	568
CV-150-M1	2	16	276	24	413	31	534
	3	17	293	26	448	34	586
	5	19	327	29	500	37	637
CV-200-M1	2	22	379	32	551	41	706
	3	25	431	36	620	46	792
	5	29	500	41	706	52	896
CV-300-M1/M2 * * lower coil	2	25	431	37	637	48	827
	4	31	534	45	775	59	1016
	6	34	586	49	844	65	1120
CV-400-M1/M2 * * lower coil	2	25	431	36	620	47	810
	4	30	517	43	741	57	982
	6	33	568	48	827	63	1085
CV-500-M1/M2 * * lower coil	2	27	465	39	672	52	896
	4	33	568	49	844	64	1102
	6	37	637	55	947	71	1223
CV-800-M1/M2 * * lower coil	3	35	603	52	896	68	1171
	5	42	723	61	1051	80	1378
	8	47	810	70	1206	92	1585
CV-1000-M1/M2 * * lower coil	3	38	655	56	965	74	1275
	5	45	775	66	1137	88	1516
	8	51	878	76	1309	101	1740
CV-1500-M1/M2 * lower coil	3	53	913	78	1344	100	1722
	5	61	1051	90	1550	118	2033
	8	69	1189	102	1757	132	2274
CV-300/400-M2 ** * upper coil	2	13	224	20	344	27	465
	4	16	276	24	413	33	568
	6	18	310	27	465	36	620
CV-500-M2 ** * upper coil	2	19	327	28	482	38	655
	4	23	396	34	586	45	775
	6	25	431	37	637	50	861
CV-800/1000-M2 ** * upper coil	2	21	362	31	534	41	706
	4	25	431	38	655	49	844
	6	28	482	42	723	54	930
CV-1500-M1/M2 ** * upper coil	2	21	362	31	534	41	706
	4	25	431	38	655	49	844
	6	28	482	42	723	54	930

CORAL VITRO - COIL, models M1S [Continuous flow DHW production (liters/hour) 10°C - 60°C]

PRIMARY INPUT TEMPERATURE °C		70 °C		80 °C		90 °C	
tank model	primary pump flow (m³/h)	KW	DHW (l/h)	KW	DHW (l/h)	KW	DHW (l/h)
CV-80-M1S	0,2	4	69	6	103	-	-
	0,6	6	103	8	138	-	-
	1	7	121	10	172	-	-
CV-110-M1S	0,2	5	86	8	138	-	-
	0,6	8	138	12	207	-	-
	1	10	172	14	241	-	-
CV-150-M1S	0,2	6	103	9	155	-	-
	0,6	9	155	14	241	-	-
	1	11	189	17	293	-	-
CV-200-M1S	0,4	10	172	15	258	-	-
	1	13	224	20	344	-	-
	1,5	15	258	23	396	-	-
CV-300-M1S	0,4	12	206	17	292	-	-
	1	17	292	24	413	-	-
	1,5	19	327	27	465	-	-

CORAL VITRO - COIL, models HL [Continuous flow DHW production (liters/hour) 10°C - 45°C]

PRIMARY INPUT TEMPERATURE °C		55 °C		70 °C		80 °C		90 °C	
tank model	primary pump flow (m³/h)	KW	DHW (l/h)	KW	DHW (l/h)	KW	DHW (l/h)	KW	DHW (l/h)
CV-200-HL	2	24	591	44	1083	57	1403	72	1772
	4	29	714	56	1378	74	1821	92	2264
	6	33	812	63	1550	84	2067	104	2559
CV-300-HL	2	29	714	54	1329	70	1722	88	2165
	4	37	910	70	1722	90	2215	115	2830
	6	42	1033	79	1944	102	2510	131	3224
CV-400-HL	2	37	910	68	1673	88	2165	107	2633
	4	50	1230	87	2141	115	2830	143	3519
	6	58	1427	98	2411	131	3224	164	4036
CV-500-HL	2	37	910	68	1673	88	2165	107	2633
	4	50	1230	87	2141	115	2830	143	3519
	6	58	1427	98	2411	131	3224	164	4036
CV-800-HL	3	53	1304	94	2313	117	2879	141	3470
	5	63	1550	116	2854	143	3519	169	4159
	8	72	1772	136	3347	167	4109	194	4774
CV-1000-HL	3	55	1353	99	2436	122	3002	147	3617
	5	65	1599	120	2953	148	3642	178	4380
	8	74	1821	140	3445	172	4232	206	5069

CORAL VITRO - COIL, models HL [Continuous flow DHW production (liters/hour) 10°C - 60°C]

PRIMARY INPUT TEMPERATURE °C		70 °C		80 °C		90 °C	
tank model	primary pump flow (m³/h)	KW	DHW (l/h)	KW	DHW (l/h)	KW	DHW (l/h)
CV-200-HL	2	32	551	45	775	58	999
	4	42	723	58	999	76	1309
	6	47	817	67	1152	86	1477
CV-300-HL	2	47	810	60	1033	75	1292
	4	59	1016	78	1344	98	1688
	6	68	1171	88	1516	110	1895
CV-400-HL	2	50	861	67	1154	88	1516
	4	65	1120	86	1482	115	1981
	6	74	1275	98	1688	130	2239
CV-500-HL	2	50	861	67	1154	88	1516
	4	65	1120	86	1482	115	1981
	6	74	1275	98	1688	130	2239
CV-800-HL	3	74	1275	94	1619	118	2033
	5	90	1550	116	1998	141	2429
	8	105	1809	135	2325	165	2842
CV-1000-HL	3	75	1292	98	1688	120	2067
	5	94	1619	120	2067	149	2567
	8	110	1895	141	2429	172	2963

CORAL VITRO - COIL models - M1 - (DHW production - peak flow -)

		CV110M1	CV150M1	CV200M1	CV300M1	CV400M1	CV500M1	CV800M1	CV1000M1	CV1500M1
Peak flow 40°C	L/10'	170	230	435	605	835	1085	1625	1950	3140
Peak flow 45°C	L/10'	145	200	370	520	715	930	1395	1670	2695
Peak flow 60°C	L/10'	100	140	260	365	500	650	975	1170	1885
Peak flow 40°C	L/60'	1060	1160	1810	2330	2505	2960	4105	4935	6665
Peak flow 45°C	L/60'	885	975	1515	1960	2105	2490	3460	4160	5630
Peak flow 60°C	L/60'	525	615	930	1185	1295	1555	2140	2440	3565
Continuous flow 40°C	Ltrs/h	1070	1115	1650	2070	2005	2250	2975	3580	4230
Continuous flow 45°C	Ltrs/h	890	930	1375	1725	1670	1875	2480	2985	3525
Continuous flow 60°C	Ltrs/h	510	570	801	985	955	1085	1395	1525	2015
Heating time (from 10 to 75°C)	Min	29	35	43	48	53	56	63	70	81
Primary flow	m³/h	5	5	5	6	6	6	8	8	8

Primary input temperature 85°C

CORAL VITRO - COIL models - M2 / M2B - (DHW production - peak flow -)

LOWER COIL		CV300M2	CV400M2	CV500M2	CV800M2	CV1000M2	CV1500M2	CV800M2B	CV1000M2B	CV1500M2B
Peak flow 40°C	L/10'	605	835	1085	1625	1950	3140	1625	1950	3140
Peak flow 45°C	L/10'	520	715	930	1395	1670	2695	1395	1670	2695
Peak flow 60°C	L/10'	365	500	650	975	1170	1885	975	1170	1885
Peak flow 40°C	L/60'	2330	2505	2960	4105	4935	6665	4105	4935	6665
Peak flow 45°C	L/60'	1960	2105	2490	3460	4160	5630	3460	4160	5630
Peak flow 60°C	L/60'	1185	1295	1555	2140	2440	3565	2140	2440	3565
Continuous flow 40°C	Ltrs/h	2070	2005	2250	2975	3580	4230	2975	3580	4230
Continuous flow 45°C	Ltrs/h	1725	1670	1875	2480	2985	3525	2480	2985	3525
Continuous flow 60°C	Ltrs/h	985	955	1085	1395	1525	2015	1395	1525	2015
Heating time (from 10 to 75°C)	Min	48	53	56	63	70	81	63	70	81
Primary flow	m³/h	6	6	6	8	8	8	8	8	8

Primary input temperature 85°C

CORAL VITRO - COIL models - HL / HLB - (DHW production - peak flow -)

		CV200HL	CV300HL	CV400HL	CV500HL	CV800HL	CV1000HL	CV800HLB	CV1000HLB
Peak flow 40°C	L/10'	435	605	835	1085	1625	1950	1625	1950
Peak flow 45°C	L/10'	370	520	715	930	1395	1670	1395	1670
Peak flow 60°C	L/10'	260	365	500	650	975	1170	975	1170
Peak flow 40°C	L/60'	2750	3470	4455	4705	6065	6605	6065	6605
Peak flow 45°C	L/60'	2295	2910	3730	3945	5095	5550	5095	5550
Peak flow 60°C	L/60'	1355	1785	2140	2290	3080	3415	3080	3415
Continuous flow 40°C	Ltrs/h	2775	3440	4345	4345	5330	5585	5330	5585
Continuous flow 45°C	Ltrs/h	2310	2865	3620	3620	4440	4655	4440	4655
Continuous flow 60°C	Ltrs/h	1314	1705	1965	1965	2525	2696	2525	2696
Heating time (from 10 to 75°C)	Min	26	32	35	39	45	54	45	54
Primary flow	m³/h	6	6	6	6	8	8	8	8

Primary input temperature 85°C

CORAL VITRO - DOUBLE WALL models - P / C - (DHW production - peak flow -)

		CV600P	CV800P	CV1000P	CV600C	CV800C	CV1000C
Peak flow 40°C	L/10'	315	315	420	315	315	420
Peak flow 45°C	L/10'	270	270	360	270	270	360
Peak flow 60°C	L/10'	185	185	255	185	185	255
Peak flow 40°C	L/60'	1160	1160	1490	1160	1160	1490
Peak flow 45°C	L/60'	970	970	1245	970	970	1245
Peak flow 60°C	L/60'	585	585	765	585	585	765
Continuous flow 40°C	Ltrs/h	1015	1015	1285	1015	1015	1285
Continuous flow 45°C	Ltrs/h	840	840	1060	840	840	1060
Continuous flow 60°C	Ltrs/h	480	480	615	480	480	615
Heating time (from 10 to 75°C)	Min	45	45	55	45	45	55
Primary flow	m³/h	5	5	5	5	5	5

Primary input temperature 85°C

CORAL VITRO "DOUBLE WALL" (models P y C)

Threaded immersion electric heating elements, specific for primary heating circuit.

electric element model	KW	V	Ceramic electric heating elements	optional application to tank models
RI 4/2-22	2,2	230 / 400	260	CV-600-...-1000P/C
RI 4/2-54	5,4	400	345	CV-600-...-1000P/C
RI 4/2-72	7,2	400	445	CV-600-...-1000P/C
RI 4/2-90	9,0	400	505	CV-600-...-1000P/C
RI 4/2-120	12,0	400	680	CV-600-...-1000P/C

CORAL VITRO "SINGLE WALL" (STORAGE and COIL tank models)

All CORAL VITRO DHW tanks, can be equipped with flanged electric heaters, whether for main DHW production as for backup heating. Applications of the heating elements with respect to the different tank models are summarized in the following table:

Incoloy, flanged immersion electric heating elements

electric element model	KW	V	length L*	optional application to tank models
RB-25	2,5	230	310	CV-200...1000-R/M1/HL CV-300...1000-M2
RB-50	5	230/400	310	CV-200...1000-R/M1/HL CV-300...1000-M2
RB-75	7,5	230/400	440	CV-200...1000-R CV-800/1000-M1/M2/HL
RB-100	10,0	230/400	580	CV-500...1000-R

Ceramic electric heating elements

electric element model	KW	V	length L*	optional application to tank models
RCER-12	1,2	230/400	300	CV-80...300-M1S
RCER-15	1,5	230/400	300	CV-80...300-M1S

Ceramic electric heating elements, sheathed in enamelled steel plate. Enamelled steel plate set + ceramic electric element, for side hole mounting

electric element model	KW	V	length L*	optional application to tank models
RCER-12	1,2	230/400	300	CV-110...1000-R/M1/M2/HL
RCER-15	1,5	230/400	300	CV-110...1000-R/M1/M2/HL
RCER-20	2,0	230/400	400	CV-200...1000-R CV-400...1000-M1/M2/HL
RCER-24	2,4	230/400	400	CV-200...1000-R CV-400...1000-M1/M2/HL

ceramic electric heating elements	enamelled plate with 2 sheaths - ref.	heating elements amount	KW
RCER-12	PLV2V	2	2,4
RCER-15	PLV2V	2	3,0
RCER-20	PLV2V	2	4,0
RCER-24	PLV2V	2	4,8

Incoloy, threaded immersion electric heating elements

electric element model	KW	V	IP	Thread	length L*	optional application to tank models
RA3/2-25	2,5	230	40	1 1/2" M	540	CV-800...1500-M1/M2/RB
RA3/2-25T(*)	2,5	230	65	1 1/2" M	350	CV-800...1500-M1/M2/RB
RA3/2-50	5,0	230/400	40	1 1/2" M	690	CV-800...1500-M1/M2/RB

(*) Model RA 3/2-25T, incorporates regulation and safety thermostat in an IP65 head.

CORAL VITRO "SINGLE WALL" (models "RB", with side manhole ND400)

Incoloy threaded immersion electric heating elements for ND400 side manhole on models GX-800/1000-RB. ND400 stainless steel plate set with 2" F bushings + selected type and number of electric elements. Number of electric elements per plate on side manhole ND400: 3,4,5,6,7 or 8 units.

electric element model	KW	V	IP	Thread	length L*	optional application to tank models
RA4/2-60	6,0	230/400	40	2"	797	CV-800...1500-RB
RA4/2-120D	12,0	230/400	40	2"	680	CV-800...1500-RB

Ceramic electric heating elements sheathed in stainless steel plate for ND400 side manhole on models GX-800/1000-RB. Stainless steel plate set with sleeves for ceramic electric elements + selected number of electric elements. Number of electric elements per plate on side manhole ND400: 3,4,5,6,7 or 8 units.

electric element model	KW	V	length L*	optional application to tank models
RCER-45	4,5	230/400	800	CV-800...1500-RB



"RI" HEATING ELEMENTS: Threaded immersion heating elements for primary heating circuit, in CORAL VITRO "DOUBLE-WALL" models.



"RB" HEATING ELEMENTS: Flanged heating element for CORAL VITRO "SINGLE-WALL", STORAGE AND COIL models.



SHEATHED "RCER" HEATING ELEMENTS ON FLANGED PLATE: Flanged ceramic heating element for CORAL VITRO "SINGLE WALL", STORAGE AND COIL models.

Sheathed **ceramic** heating elements on vitreous enamelled steel plate for side hole. Vitreous enamelled steel plate + ceramic heating elements for mounting in side hole.



"RA" HEATING ELEMENTS: Threaded heating elements for backup heating in CORAL VITRO "SINGLE-WALL", STORAGE and COIL models

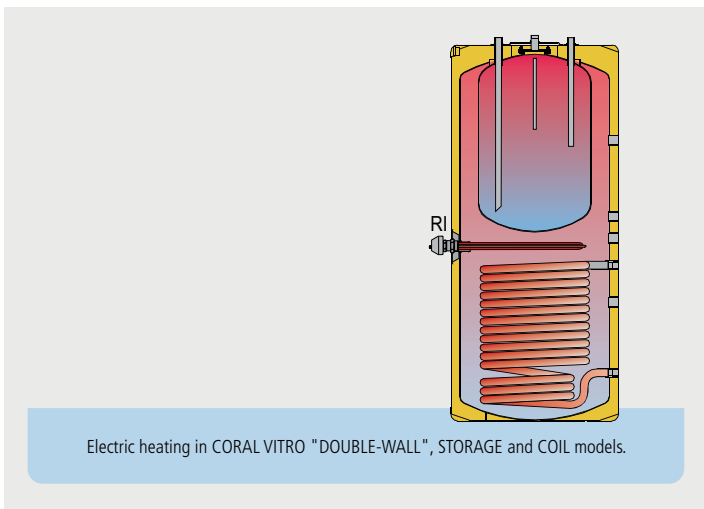

Electric heating in CORAL VITRO "DOUBLE-WALL", STORAGE and COIL models.

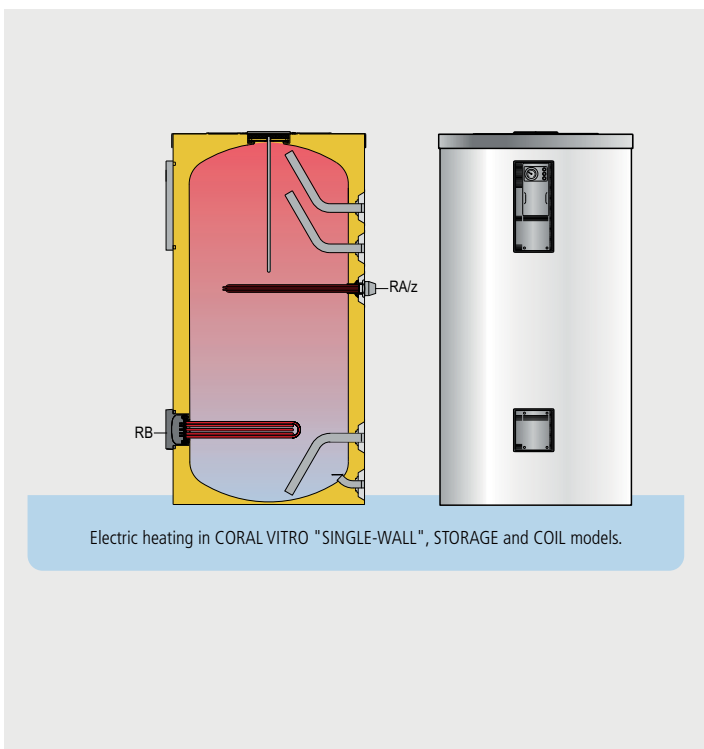

Electric heating in CORAL VITRO "SINGLE-WALL", STORAGE and COIL models.

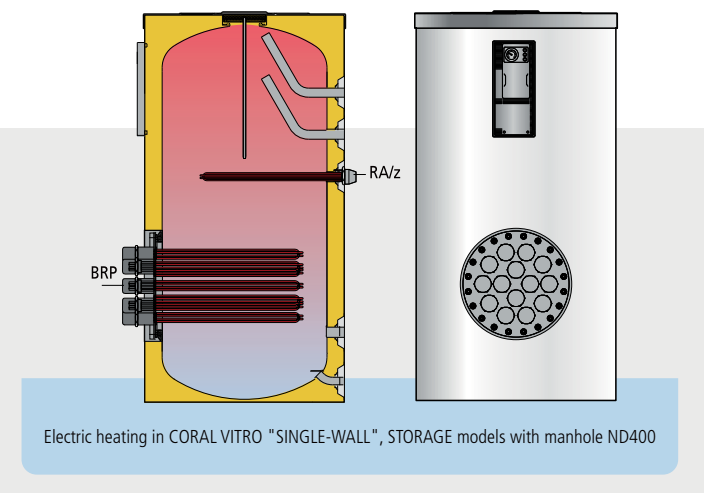

Electric heating in CORAL VITRO "SINGLE-WALL", STORAGE models with manhole ND400



"lapesa" control panels are integrated into the different types of tanks in the "CORAL VITRO" series. They are supplied fully wired and mounted on the tank. The panels include all the necessary components to control the temperature of the DHW stored in the tank and for the thermostatic control of the installation's heating equipment. Any of the standard control panels fitted in tanks can be replaced by another type of control panel, if the installation so requires.

CONTROL PANEL COMPONENTS:

- [Te°] Thermometer: 0 - 120°C
- [TL°] Control thermostat: 0 - 75°C
- [TL°] Safety thermostat: 90°C
- ❄️/⚙️ Switch: winter - summer
- Power on LED: green
- Primary pump LED: amber
- Electric heating element LED: red
- [P] Analog time switch: electric heating element.

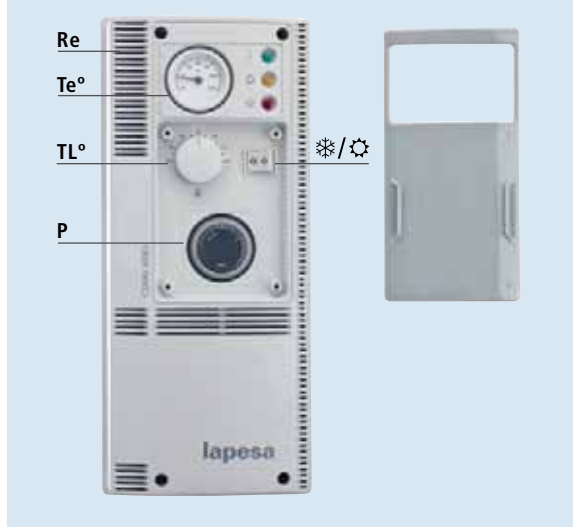

COMPONENTS ON CONTROL PANELS

CONTROL PANEL	INCORPORATED COMPONENTS								
Denomination	Thermometer	Regulation thermostat	Safety thermostat	Switch ON/OFF	SWITCH SUMMER/WINTER	LEDS	Analog time switch	Regulation	Standard installed on tank models "CORAL VITRO"
"T" PANEL	YES								CV-...-R/RB/P/HL
"TS" PANEL	YES	YES						hydraulic primary circuit	CV-...-M1/M2
"TD" PANEL	YES	YES	YES	YES	YES	YES		hydraulic primary circuit / electric heating element	(*)
"TPA" PANEL	YES	YES	YES	YES	YES	YES	YES	hydraulic primary circuit / electric heating element / time programming	(*)

(*) Optional: Any of the standard control panels fitted in tanks can be replaced by another type of control panel, if the installation so requires.



The **"CORAL VITRO"** series are thermally insulated at the factory by direct mould-injection with CFC- and HCFC-free PU material.

This system guarantees a perfectly regular insulation thickness with optimum material density. The thicknesses indicated in the table refer to the circular tank body, but the insulation is much thicker on the top part (up to four times greater). Because the top part of the tank has better thermal protection, heat losses are much lower than those specified by the most stringent regulations, such as the DIN 4753/8 standard.



Rigid, mould-injected PU insulating material

- *Minimal heat loss!*
- *For hot and cold water!*
- *No condensation on tank body!*
- *Compact block, no joints!*

TABLE OF THERMAL INSULATION: SERIE CORAL VITRO

Serie	Model	Thermal insulation k= 0,025 W/m °K	Insulation thickness PU (mm.)	Static heat losses EN 12897 (W)	ErP (EU 812/2013)	Minimum thickness of equivalent insulation with other insulating materials (mm)		
						Flexible polyurethane foam* k= 0,040 W/m °K	Rockwool* k= 0,034 - 0,042 W/m °K	Fiberglass* k= 0,035 - 0,046 W/m °K
CORAL VITRO	CV-80-M1S	PU	45	46	B	75	65 - 80	65 - 90
CORAL VITRO	CV-110-M1/M1S	PU	45	46	B	75	65 - 80	65 - 90
CORAL VITRO	CV-150-M1/M1S/GS	PU	55	44	B	90	75 - 95	75 - 110
CORAL VITRO	CV-200-R/M1/M1S/M2/HL/GS	PU	50	56	B	80	70 - 85	70 - 95
CORAL VITRO	CV-300-R/M1/M1S/M2/HL/GS	PU	50	67	B	80	70 - 85	70 - 95
CORAL VITRO	CV-400-M2/HL	PU	50	88	C	80	70 - 85	70 - 95
CORAL VITRO	CV-500-R/M1/M2/HL/GS	PU	50	93	C	80	70 - 85	70 - 95
CORAL VITRO	CV-600-P/C	PU	50	105	C	80	70 - 85	70 - 95
CORAL VITRO	CV-800-R/M1/M2/HL/P/C	PU	80	89	B	130	110 - 140	115 - 160
CORAL VITRO	CV-800-RB/M1B/M2B/HLB	PU	80	97	B	130	110 - 140	115 - 160
CORAL VITRO	CV-1000-R/M1/M2/HL/P/C	PU	80	115	C	130	110 - 140	115 - 160
CORAL VITRO	CV-1000-RB/M1B/M2B/HLB	PU	80	125	C	130	110 - 140	115 - 160
CORAL VITRO	CV-1500-R/M1/M2	PU	80	156	C	130	110 - 140	115 - 160
CORAL VITRO	CV-1500-RB/M1B/M2B	PU	80	169	C	130	110 - 140	115 - 160

(*) Detachable systems can lose up to 25% of the insulating capacity overall, so that in that case the insulation thickness will increased proportionally



CATHODIC PROTECTION SYSTEM IN "CORAL VITRO" SERIES.

The CORAL VITRO series of tanks include, as a standard feature, a cathodic protection unit comprising magnesium anodes and an anode charge meter. In cathodic protection systems with sacrificial anodes, the anodes must be checked periodically for wear and replaced if necessary. The anode charge meter is a simple, convenient system for users to check the state of the anode. All you have to do is to check if the dial indicator is in the green zone (anode with sufficient charge) or the red zone (anode with insufficient charge = the anode needs to be replaced).

All DHW tanks made of carbon steel with an inner lining should be equipped with the cathodic protection system (DIN 4753)
Cathodic protection units differ in terms of size and number of anodes depending on the model, the geometry and the capacity of the "CORAL VITRO" storage tank.



"LAPESA CORREX-UP" PERMANENT CATHODIC PROTECTION SYSTEM.

Totally automatic! "lapesa correx-up", cathodic protection system comprises special titanium anodes that emit the necessary current for the metal surface to be protected by means of an automatic potentiostat connect to the mains power supply.

Maintenance free! This cathodic protection system is permanent which means that, unlike sacrificial anodes, there is no wear and the anodes do not need to be replaced.



"lapesa correx-up" permanent cathodic protection system: Maintenance-free permanent cathodic protection unit. These anodes do not wear out and they emit the necessary electric current automatically, providing the tank with cathodic protection via an individual potentiostat for each anode, connected to the mains electricity.



ACCESSORIES - CORAL VITRO

EXTERNAL LINING:

External linings for "CORAL VITRO" tanks. Padded PVC lining with zip fastener, B2 class according to DIN 4102-1. Standard external lining: WHITE / RAL. Rest of colours OPTIONAL, according to availability and the quantities of product ordered.



WHITE: RAL 9016



GREY: RAL 7045



BLUE: RAL 5015

ALUNOX EXTERNAL LINING

External aluminium sheet lining. ALUNOX external lining is supplied ready-mounted on the tank, over the PU insulation.



SAFETY GROUP

Safety group set at 7 bar and 3/4" connection.
Set of safety valve, non-return valve, stop-cock and connection from trap to drain.
3/4" valve KIT
1" valve KIT



ELECTRIC HEATING ELEMENT, DOUBLE-WALL MODELS.

Electric element in AISI 321 specifically for "CORAL VITRO" DOUBLE-WALL tanks, "P" and "C" models
Characteristics and power range: page: 86 -ELECTRIC HEATING-

THREADED ELECTRIC HEATING ELEMENT, STORAGE AND COIL MODELS.

Low charge density, threaded immersion electric element in Incoloy for "CORAL VITRO" STORAGE and COIL tanks, "R", "RB", "M1" and "M2" models.
Characteristics and power range: page: 86 -ELECTRIC HEATING-

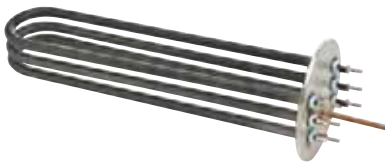

FLANGED ELECTRIC HEATING ELEMENT, STORAGE AND COIL MODELS.

Low charge density, flanged immersion electric element in Incoloy for "CORAL VITRO" STORAGE and COIL tanks, "R", "M1" and "M2" models.

CERAMIC ELECTRIC HEATING ELEMENT, STORAGE AND COIL MODELS.

Sheathed ceramic electric element for "CORAL VITRO" STORAGE and COIL tanks, "R", "M1" and "M2" models.
Characteristics and power range: page: 86 -ELECTRIC HEATING-



"LAPESA CORREX-UP" CATHODIC PROTECTION SYSTEM.

"lapesa correx-up" permanent cathodic protection unit for "CORAL VITRO" tanks

CATHODIC PROTECTION SYSTEM "MAGNESIUM ANODES WITH CHARGE METER"

Cathodic protection by magnesium anodes for "CORAL VITRO" tanks.



REGULATION AND CONTROL PANELS.

"CORAL VITRO" tanks.
Characteristics / applications:
page: 88 -REGULATION AND CONTROL-



MASTER VITRO - VITREOUS ENAMELLED STEEL

STORAGE models, energy savings!

Tanks designed to provide an extraordinary energy storage capacity that directly translates into real savings. - Capacities from 1500 to 6000 litres.

LARGE CAPACITY STORAGE TANKS: Designed to provide an extraordinary storage capacity that translates directly into real savings.

- CAPACITIES from 1500 to 6000 litres -

Storage tanks ready for installation with plate heat exchanger and/or electric immersion heating elements as the heating source.

ELECTRIC HEATING: Ready for installation with Incoloy, low charge density electric immersion elements or with sheathed ceramic heating elements (see ELECTRIC HEATING chapter, page: 106).

LONG-LASTING PRODUCT: VITREOUS ENAMELLED STEEL storage tank according to **DIN 4753 T3**.

Food grade impermeable lining with a porcelain look that protects the metal surface of the storage tank in contact with water.

FOOD GRADE LINING: Food grade lining according to Royal Decree 891/2006 and EC regulation 1935/2004. Lapesa has further certification of the food grade of the lining at 120°C.

MAXIMUM WORKING TEMPERATURE: It withstands maximum continuous working temperatures handled by this type of installation (95°C), without any deterioration or alteration to the lining.

EASY TO HANDLE AND TRANSPORT: Our "Master" storage tanks are designed for easy handling and transport to the place of installation.

They have an integrated system for handling and transporting by forklift truck, which facilitates handling operations enormously, as there is no need to palletize the product which, given its weight and size, would make handling difficult.

The tanks are also equipped with lifting eyebolts on the top part so that if they have to be placed in a high area they can be lifted with an overhead hoist.



TRANSPORT SYSTEM: Openings/ducts under the tank to facilitate handling with pallet trucks (from 1500 litres onward).

EASY TO MAINTAIN: With access to interior via two ND400 manholes, one in the side and the other on the top part, for inspection, cleaning and maintenance tasks.

MAXIMUM STORAGE CAPACITY: Extra thick, rigid, PU mould-injected insulation that minimizes heat losses of stored DHW (see HEAT INSULATION chapter, page: 108).

MAIN ADVANTAGES - MASTER VITRO - STORAGE

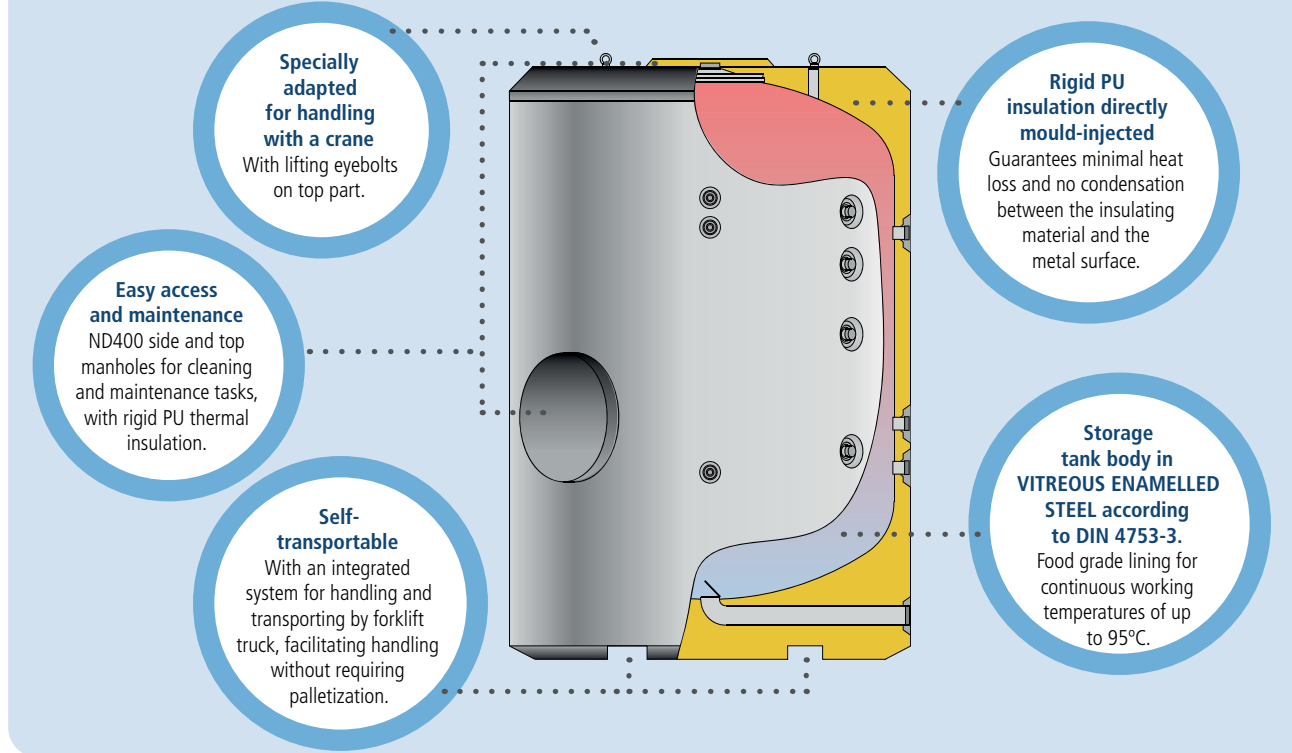

lapesa storage tanks have minimal heat losses and for this reason are considered to be one of the products with the greatest storage capacity on the market.



FEATURES COMMON TO ALL "MASTER VITRO" STORAGE MODELS:

- **Vitreous enamelled steel** DHW storage tanks according to **DIN 4753/3**
- Capacities: **1500, 2000, 2500, 3000, 3500, 4000, 5000 and 6000 litres**
- Maximum working pressure of DHW storage tank: **8 bar** (10 bar optional)
- Maximum working temperature of DHW storage tank: **95 °C**
- Thermal insulation: **Rigid, mould-injected PU** (CFC/HCFC-free, 0.025 W/m²K)
- Tanks for **VERTICAL** installation on floor. (HORIZONTAL position - optional, please consult us)

MASTER VITRO "RB"

DHW "STORAGE" tanks, from **1500** to **6000** litre capacity.

DHW production is by an external heat exchange system (plate heat exchanger).

They can be fitted with immersion electric elements or ceramic electric elements as the main and/or backup heating system. With side and top ND400 manholes to access the interior of the storage tank for inspection, cleaning and maintenance tasks.

Thermally insulated with rigid, mould-injected, 80 mm-thick, PU polyurethane foam, with insulating piece in same material on the ND400 side manhole.

EQUIPMENT:

"lapesa correx-up", permanent cathodic protection unit.

Optional: cathodic protection unit with magnesium anodes and anode charge meter.

Optional supply of PVC padded external lining and set of trims or ALUNOX aluminium sheet lining (page: 109).

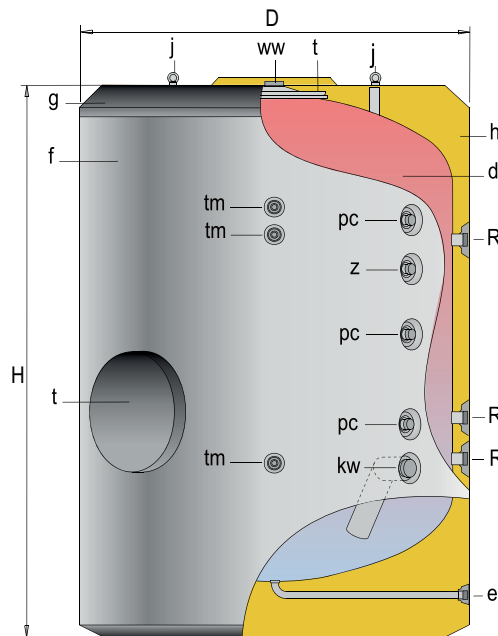

- t - Manhole ND400
- d - DHW tank
- f - Outer lining
- g - Top cover
- h - Thermal insulation
- j - Lifting eyes



GENERAL CHARACTERISTICS		MVV-1500-RB	MVV-2000-RB	MVV-2500-RB	MVV-3000-RB	MVV-3500-RB	MVV-4000-RB	MVV-5000-RB	MVV-6000-RB
DHW capacity	l.	1500	2000	2500	3000	3500	4000	5000	6000
D: external diameter	mm.	1360	1360	1660	1660	1660	1910	1910	1910
H: overall height	mm.	1830	2280	2015	2305	2580	2310	2710	3210
Diagonal	mm.	2281	2655	2611	2841	3068	2998	3316	3735
kw: cold water inlet	" GAS/M	2	2	3	3	3	3	3	3
ww: DHW outlet	" GAS/M	2	2	3	3	3	3	3	3
z: recirculation	" GAS/M	1 1/2	1 1/2	2	2	2	2	2	2
e: drain	" GAS/M	1 1/2	1 1/2	1 1/2	1 1/2	1 1/2	1 1/2	1 1/2	2
R: side connection	" GAS/M	2	2	2	2	2	2	2	2
pc: "lapesa correx up" connection	" GAS/M	1 1/2	1 1/2	1 1/2	1 1/2	1 1/2	1 1/2	1 1/2	1 1/2
tm: probe tube connection for sensors	" GAS/M	3/4	3/4	3/4	3/4	3/4	3/4	3/4	3/4
Empty weight (approx.)	Kg	400	460	635	705	755	915	1030	1134

Note: The 6000 litre model includes support legs

MASTER VITRO

tanks designed to provide an extraordinary energy storage capacity that directly translates into real savings.

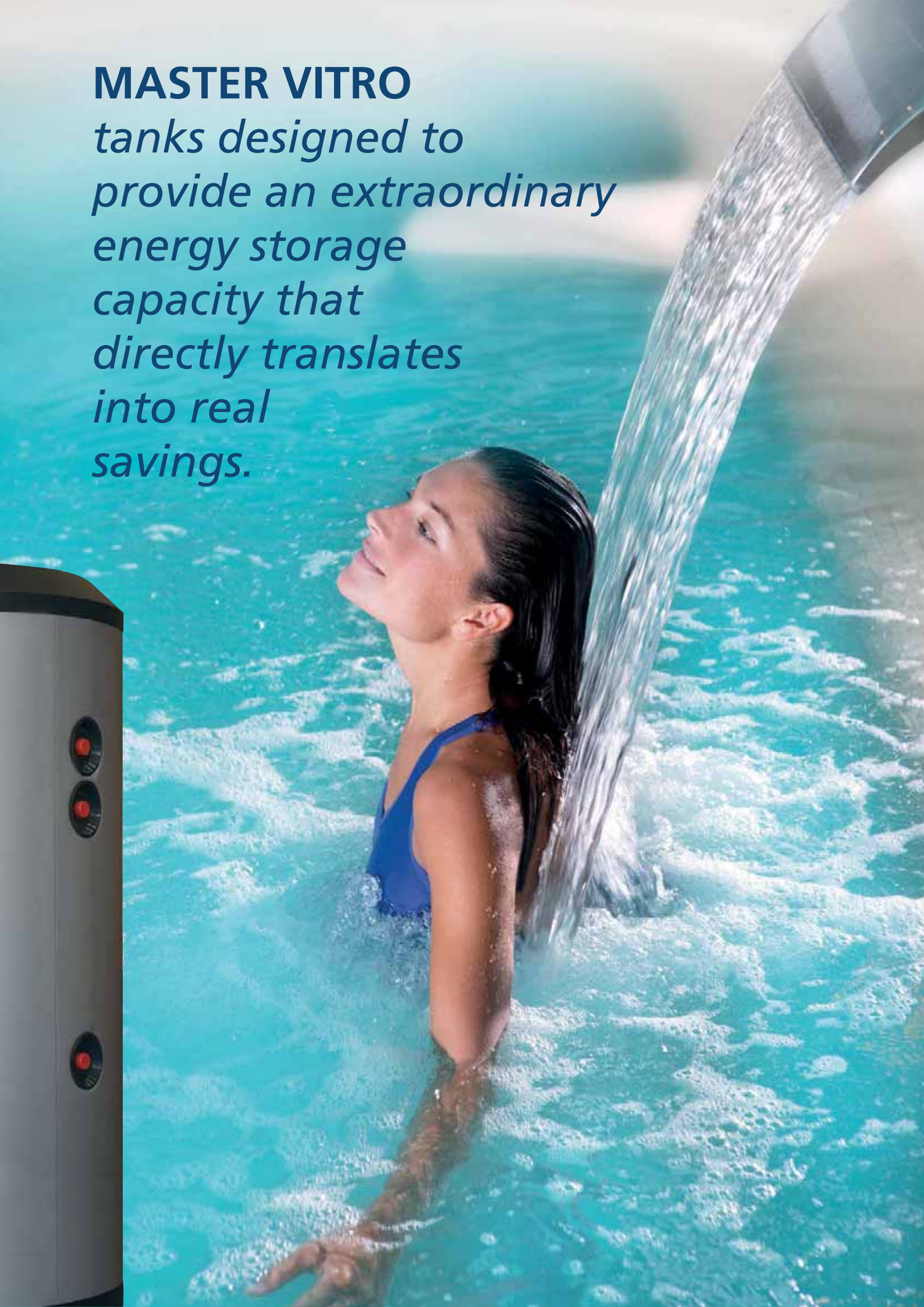



MASTER VITRO - VITREOUS ENAMELLED STEEL

Models with COILS, production and efficiency!

Storage tanks that incorporate an exclusive heat exchange system comprising a set of collectors and coils in stainless steel that are detachable from the inside of the storage tank, for DHW production via an external energy source.

LARGE CAPACITY TANKS FOR DHW PRODUCTION AND STORAGE: Storage tanks with the exclusive, high-efficiency "lapesa" DHW production system.

- CAPACITIES from 1500 to 6000 litres -

The overdimensioned, rigid, mould-injected PU thermal insulation maintains the DHW storage temperature over long periods of time without requiring additional energy input. This means less start-ups and adjustments of external energy sources, which in turn translates to less energy consumption.

Storage tanks that incorporate an exclusive heat exchange system comprising a set of collectors and coils that are detachable from the inside of the storage tank, for DHW production via an external energy source (see DHW PRODUCTION chapter, page: 104).

LONG-LASTING PRODUCT: VITREOUS ENAMELLED STEEL storage tank according to **DIN 4753 T3**

Food grade impermeable lining with a porcelain look that protects the metal surface of the storage tank in contact with water.

FOOD GRADE LINING: Food grade lining according to Royal Decree 891/2006 and EC regulation 1935/2004. Lapesa has additional certification of the food grade of the lining at 120°C.

MAXIMUM WORKING TEMPERATURE: It withstands maximum continuous working temperatures handled by this type of installation (95°C), without any deterioration or alteration to the lining.

ANTI-LEGIONELLA DESIGN: The design of the complete range of "MASTER VITRO" tanks adheres to all of the "Treatment and Prevention of Legionellosis" criteria specified in current UNE standards and EC Directives and, in particular, in the R.D. 865/2003 and the RITE (Regulations on Thermal Installations in Buildings).

The anti-legionella design applies to the storage tank unit and its internal DHW production system.

LARGE DHW PRODUCTION CAPACITY: A set of separate collectors and coils, made of STAINLESS STEEL, are fitted inside the storage tank, allowing the heat exchange surface to be dimensioned in accordance with the power required (up to 10 m² in the 6000 litre model), adapted to traditional energy sources or to the use of renewable energies.

This exclusive lapesa DHW production system for large capacity tanks, saves on installation space and allows total or partial maintenance of the unit, guaranteeing the continuous service of the installation.

MAIN ADVANTAGES - MASTER VITRO - COIL

Specially adapted for handling with a crane.
 With lifting eyebolts on top part.

Easy access and maintenance.
 ND400 side and top manholes for cleaning and maintenance tasks, with rigid PU thermal insulation.

Self-transportable.
 With an integrated system for handling and transport by forklift truck, facilitating handling without requiring palletization.

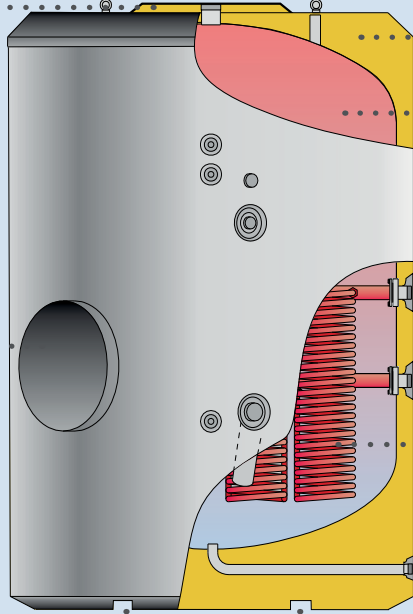

Rigid PU insulation directly mould-injected.
 Guarantees minimal heat loss and no condensation between the insulating material and the metal surface.

Storage tank body in VITREOUS ENAMELLED STEEL according to DIN 4753-3.
 Food grade lining for continuous working temperatures of up to 95°C.

Modular, detachable stainless steel coils.
 Designed to heat from the lowest zone in the tank, they guarantee the greatest DHW production capacity, taking maximum advantage of the tank capacity and acting as a perfect anti-legionella system.

lapesa's exclusive modular stainless steel coils system for LARGE CAPACITY tanks allows the unit to be adapted to the thermal output required, also enabling interventions separate from the storage tank.



Modular coils "MASTER VITRO"



FEATURES COMMON TO ALL "MASTER VITRO" MODELS WITH COILS:

- **Vitreous enamelled steel** DHW storage tanks according to **DIN 4753/3**
- Capacities: **1500, 2000, 2500, 3000, 3500, 4000, 5000 and 6000 litres**
- Maximum working pressure of DHW storage tank: **8 bar** (10 bar optional)
- Maximum working temperature of DHW storage tank: **90 °C**
- Maximum pressure of set of coils: **25 bar**
- Maximum temperature of set of coils: **110 °C** (up to 200 °C with special high temperature seals)
- Thermal insulation: **Rigid, mould-injected PU** (CFC/HCFC-free, 0.025 W/m²K)
- Tanks for **VERTICAL** installation on floor (option of **HORIZONTAL** position - please consult us)

MASTER VITRO "SB"

DHW **PRODUCTION/STORAGE** tanks, from **1500** to **6000** litre capacity.

With **detachable coils system** for DHW production via an external energy source.

They can be fitted with immersion electric elements or ceramic electric elements on the top part of the tank, as backup heating.

With side and top ND400 manholes to access the interior of the storage tank for inspection, cleaning and maintenance tasks.

Thermally insulated with rigid, mould-injected, 80 mm-thick, PU polyurethane foam, with insulating piece in same material on the ND400 side manhole.

EQUIPMENT:

"lapesa correx-up" permanent cathodic protection unit.

Optional: cathodic protection unit with magnesium anodes and anode charge meter.

Optional supply of PVC padded external lining and set of trims or ALUNOX aluminium sheet lining (page: 109).

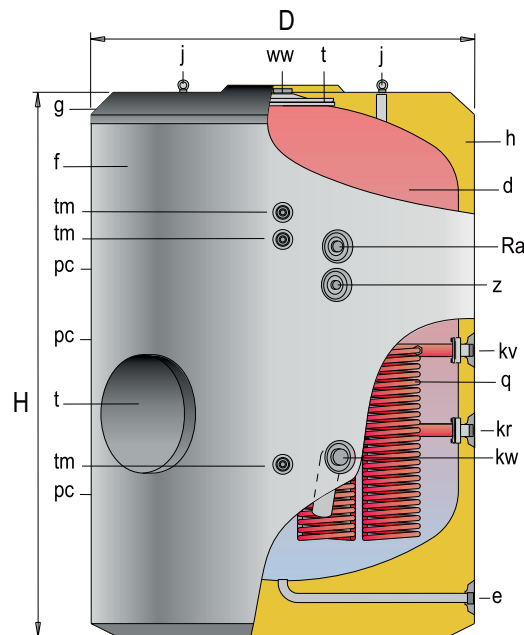

- t - Manhole ND400
- d - DHW tank
- f - Outer lining
- g - Top cover
- h - Thermal insulation
- j - Lifting eyes
- q - Detachable coils system

GENERAL CHARACTERISTICS		MVV-1500-SB	MVV-2000-SB	MVV-2500-SB	MVV-3000-SB	MVV-3500-SB	MVV-4000-SB	MVV-5000-SB	MVV-6000-SB
DHW capacity	l.	1500	2000	2500	3000	3500	4000	5000	6000
D: external diameter	mm.	1360	1360	1660	1660	1660	1910	1910	1910
H: overall height	mm.	1830	2280	2015	2305	2580	2310	2710	3210
Diagonal	mm.	2281	2655	2611	2841	3068	2998	3316	3735
kw: cold water inlet	" GAS/M	2	2	3	3	3	3	3	3
ww: DHW outlet	" GAS/M	2	2	3	3	3	3	3	3
z: recirculation	" GAS/M	1 1/2	1 1/2	2	2	2	2	2	2
e: drain	" GAS/M	1 1/2	1 1/2	1 1/2	1 1/2	1 1/2	1 1/2	1 1/2	2
Ra: backup heating element	" GAS/M	2	2	2	2	2	2	2	2
pc: "lapesa correx up" connection	" GAS/M	1 1/2	1 1/2	1 1/2	1 1/2	1 1/2	1 1/2	1 1/2	1 1/2
tm: probe tube connection for sensors	" GAS/M	3/4	3/4	3/4	3/4	3/4	3/4	3/4	3/4
kv: primary input	" GAS/M	2	2	2	2	2	2	2	2
kr: primary return	" GAS/M	2	2	2	2	2	2	2	2
Coils set heating surface	m ²	2,8	3,4	4,8	5	6,7	6,7	8,4	8,4
Empty weight (approx.)	Kg	430	495	675	740	810	980	1110	1216

Note: The 6000 litre model includes support legs

MASTER VITRO "SSB"

DHW **PRODUCTION/STORAGE** tanks, from **1500** to **6000** litre capacity.

Set of **OVERDIMENSIONED detachable coils system** for DHW production, specifically designed for the application of RENEWABLE ENERGIES, in particular, **SOLAR ENERGY**.

Heat exchange surfaces in the whole range comply with RITE requirements for SOLAR installations.

They can be fitted with immersion electric elements or ceramic electric elements on the top part of the tank, as backup heating.

With side and top ND400 manholes to access the interior of the storage tank for inspection, cleaning and maintenance tasks.

Thermally insulated with rigid, mould-injected, 80 mm-thick, PU polyurethane foam, with insulating piece in same material on the ND400 side manhole.

EQUIPMENT:

"lapesa correx-up" permanent cathodic protection unit.

Optional: cathodic protection unit with magnesium anodes and anode charge meter.

Optional supply of PVC padded external lining and set of trims or ALUNOX aluminium sheet lining (page: 109).

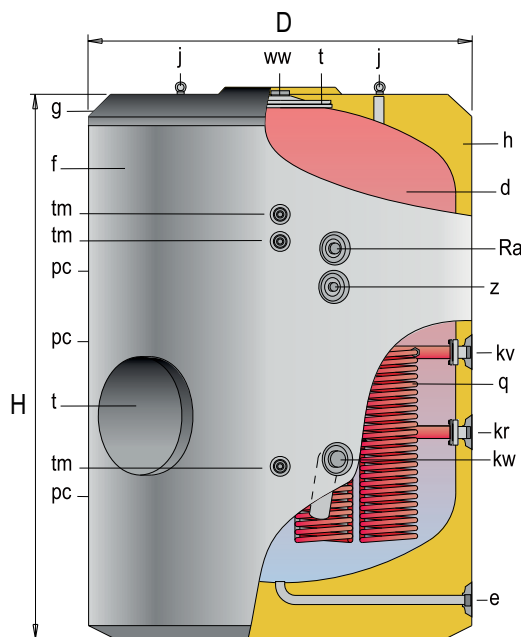

- t - Manhole ND400
- d - DHW tank
- f - Outer lining
- g - Top cover
- h - Thermal insulation
- j - Lifting eyes
- q - Detachable coils system



GENERAL CHARACTERISTICS		MVV-1500-SSB	MVV-2000-SSB	MVV-2500-SSB	MVV-3000-SSB	MVV-3500-SSB	MVV-4000-SSB	MVV-5000-SSB	MVV-6000-SSB
DHW capacity	l.	1500	2000	2500	3000	3500	4000	5000	6000
D: external diameter	mm.	1360	1360	1660	1660	1660	1910	1910	1910
H: overall height	mm.	1830	2280	2015	2305	2580	2310	2710	3210
Diagonal	mm.	2281	2655	2611	2841	3068	2998	3316	3735
kw: cold water inlet	" GAS/M	2	2	3	3	3	3	3	3
ww: DHW outlet	" GAS/M	2	2	3	3	3	3	3	3
z: recirculation	" GAS/M	1 1/2	1 1/2	2	2	2	2	2	2
e: drain	" GAS/M	1 1/2	1 1/2	1 1/2	1 1/2	1 1/2	1 1/2	1 1/2	2
Ra: backup heating element	" GAS/M	2	2	2	2	2	2	2	2
pc: "lapesa correx up" connection	" GAS/M	1 1/2	1 1/2	1 1/2	1 1/2	1 1/2	1 1/2	1 1/2	1 1/2
tm: probe tube connection for sensors	" GAS/M	3/4	3/4	3/4	3/4	3/4	3/4	3/4	3/4
kv: primary input	" GAS/M	2	2	2	2	2	2	2	2
kr: primary return	" GAS/M	2	2	2	2	2	2	2	2
Coils set heating surface	m2	4,2	5,0	6,1	8,4	8,4	8,4	10,0	10,0
Empty weight (approx.)	Kg	445	510	685	765	825	995	1120	1228

Note: The 6000 litre model includes support legs

MASTER VITRO "S2B / SS2B"

DHW **PRODUCTION/STORAGE** tanks, **2000, 3500, 5000** and **6000** litre capacity.

"SB" and "SSB" base models with **TWO detachable coils systems** for DHW production via two combined external energy sources.

With ND400 side manhole for access to interior of tank for inspection, cleaning treatments and maintenance.

Thermally insulated with rigid, mould-injected, 80 mm-thick, PU polyurethane foam, with insulating piece in same material on the ND400 side manhole.

EQUIPMENT:

"lapesa correx-up" permanent cathodic protection unit.

Optional: cathodic protection unit with magnesium anodes and anode charge meter.

Optional supply of PVC padded external lining and set of trims or ALUNOX aluminium sheet lining (page: 109).

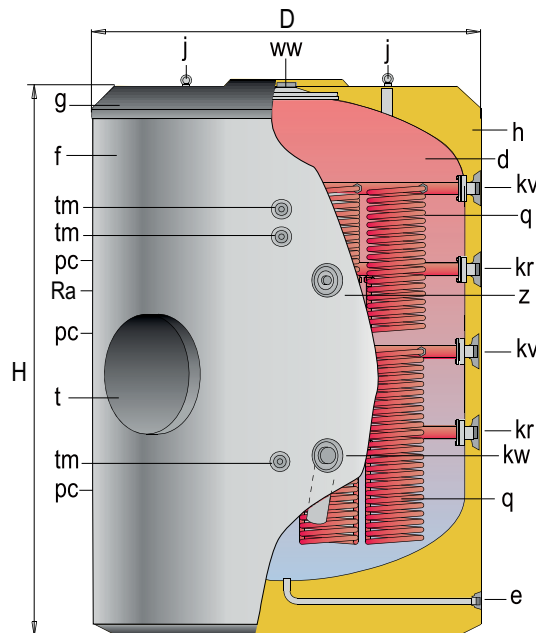

- d - DHW tank
- f - Outer lining
- g - Top cover
- h - Thermal insulation
- j - Lifting eyes
- t - Manhole ND400

GENERAL CHARACTERISTICS		MVV-2000 S2B / SS2B	MVV-3500 S2B / SS2B	MVV-5000 S2B / SS2B	MVV-6000 S2B / SS2B
DHW capacity	l.	2000	3500	5000	6000
D: external diameter	mm.	1360	1660	1910	1910
H: overall height	mm.	2280	2580	2710	3210
Diagonal	mm.	2655	3068	3316	3735
kw: cold water inlet	" GAS/M	2	3	3	3
ww: DHW outlet	" GAS/M	2	3	3	3
z: recirculation	" GAS/M	1 1/2	2	2	2
e: drain	" GAS/M	1 1/2	1 1/2	1 1/2	2
pc: "lapesa correx up" connection	" GAS/M	1 1/2	1 1/2	1 1/2	1 1/2
Ra: side connection	" GAS/M	3	3	3	3
tm: probe tube connection for sensors	" GAS/M	3/4	3/4	3/4	3/4
kv: primary input	" GAS/M	2	2	2	2
kr: primary return	" GAS/M	2	2	2	2
Lower coils set heating surface "S2B"	m ²	3,4	6,7	8,4	8,4
Lower coils set heating surface "SS2B"	m ²	5,0	8,4	10,0	10,0
Upper coils set heating surface "S2B" / "SS2B"	m ²	1,7/3,1	3,2/4,0	4,0/4,8	4,0/4,8
Empty weight (approx.) "S2B" / "SS2B"	Kg	524 / 544	855 / 870	1140 / 1160	1273/ 1285

Note: The 6000 litre model includes support legs

MASTER VITRO

*The best investment
for your installation!*

- unbeatable storage capacity
- high-performance service
- guarantee of quality

The large capacity tank
that pays for itself!

lapesa
Solutions

MASTER VITRO - COILS - SB [Continuous flow DHW production (liters/hour) 10°C - 45°C]

PRIMARY INPUT TEMPERATURE °C		55 °C		70 °C		80 °C		90 °C	
tank model	primary pump flow (m³/h)	KW	DHW (l/h)	KW	DHW (l/h)	KW	DHW (l/h)	KW	DHW (l/h)
MVV-1500-SB	3	39	960	72	1772	98	2411	119	2928
	5	46	1132	85	2092	118	2904	143	3519
	8	52	1280	98	2411	137	3371	166	4085
MVV-2000-SB	3	44	1083	86	2116	109	2682	136	3347
	5	51	1255	104	2559	133	3273	165	4060
	8	58	1427	121	2977	154	3789	191	4700
MVV-2500-SB	3	53	1304	92	2264	119	2928	146	3593
	5	63	1550	113	2781	147	3617	180	4429
	8	72	1772	132	3248	172	4232	211	5192
MVV-3000-SB	3	61	1501	107	2633	141	3470	174	4282
	5	74	1821	134	3297	178	4380	220	5414
	8	86	2116	158	3888	212	5217	262	6447
MVV-3500-SB	3	71	1747	132	3248	181	4454	224	5512
	5	87	2141	165	4060	228	5610	284	6988
	8	102	2510	196	4823	270	6644	340	8366
MVV-4000-SB	3	71	1747	132	3248	181	4454	224	5512
	5	87	2141	165	4060	228	5610	284	6988
	8	102	2510	196	4823	270	6644	340	8366
MVV-5000-SB	3	83	2042	156	3839	211	5192	263	6472
	5	102	2510	197	4848	268	6595	337	8293
	8	120	2953	234	5758	321	7899	406	9990
MVV-6000-SB	3	83	2042	156	3839	211	5192	263	6472
	5	102	2510	197	4848	268	6595	337	8293
	8	120	2953	234	5758	321	7899	406	9990

MASTER VITRO - COILS - SSB [Continuous flow DHW production (liters/hour) 10°C - 45°C]

PRIMARY INPUT TEMPERATURE °C		55 °C		70 °C		80 °C		90 °C	
tank model	primary pump flow (m³/h)	KW	DHW (l/h)	KW	DHW (l/h)	KW	DHW (l/h)	KW	DHW (l/h)
MVV-1500-SSB	3	53	1304	92	2264	119	2928	146	3593
	5	63	1550	113	2781	147	3617	180	4429
	8	72	1772	132	3248	172	4232	211	5192
MVV-2000-SSB	3	61	1501	107	2633	141	3470	174	4282
	5	74	1821	134	3297	178	4380	220	5414
	8	86	2116	158	3888	212	5217	262	6447
MVV-2500-SSB	3	64	1575	119	2928	161	3962	199	4897
	5	78	1919	149	3666	204	5020	251	6176
	8	90	2215	177	4355	243	5979	299	7357
MVV-3000-SSB	3	83	2042	156	3839	211	5192	263	6472
	5	102	2510	197	4848	268	6595	337	8293
	8	120	2953	234	5758	321	7899	406	9990
MVV-3500-SSB	3	83	2042	156	3839	211	5192	263	6472
	5	102	2510	197	4848	268	6595	337	8293
	8	120	2953	234	5758	321	7899	406	9990
MVV-4000-SSB	3	83	2042	156	3839	211	5192	263	6472
	5	102	2510	197	4848	268	6595	337	8293
	8	120	2953	234	5758	321	7899	406	9990
MVV-5000-SSB	3	100	2461	177	4364	243	5973	301	7401
	5	125	3076	226	5569	314	7715	392	9657
	8	148	3642	271	6677	379	9319	477	11732
MVV-6000-SSB	3	100	2461	177	4364	243	5973	301	7401
	5	125	3076	226	5569	314	7715	392	9657
	8	148	3642	271	6677	379	9319	477	11732

MASTER VITRO - COILS - SB [Continuous flow DHW production (liters/hour) 10°C - 60°C]

PRIMARY INPUT TEMPERATURE °C		70 °C		80 °C		90 °C	
tank model	primary pump flow (m³/h)	KW	DHW (l/h)	KW	DHW (l/h)	KW	DHW (l/h)
MVV-1500-SB	3	46	792	73	1257	94	1619
	5	55	947	89	1533	114	1964
	8	64	1102	103	1774	132	2274
MVV-2000-SB	3	55	947	80	1378	107	1843
	5	67	1154	98	1688	131	2256
	8	78	1344	114	1964	152	2618
MVV-2500-SB	3	59	1016	87	1499	115	1981
	5	72	1240	108	1860	143	2463
	8	85	1464	128	2205	168	2894
MVV-3000-SB	3	68	1171	104	1791	137	2360
	5	86	1481	131	2256	174	2997
	8	102	1757	157	2704	209	3600
MVV-3500-SB	3	85	1464	133	2291	177	3049
	5	106	1826	168	2894	226	3893
	8	126	2170	200	3445	270	4651
MVV-4000-SB	3	85	1464	133	2291	177	3049
	5	106	1826	168	2894	226	3893
	8	126	2170	200	3445	270	4651
MVV-5000-SB	3	100	1722	155	2670	208	3583
	5	127	2188	198	3411	268	4616
	8	151	2601	238	4100	323	5564
MVV-6000-SB	3	100	1722	155	2670	208	3583
	5	127	2188	198	3411	268	4616
	8	151	2601	238	4100	323	5564

MASTER VITRO - COILS - SSB [Continuous flow DHW production (liters/hour) 10°C - 60°C]

PRIMARY INPUT TEMPERATURE °C		70 °C		80 °C		90 °C	
tank model	primary pump flow (m³/h)	KW	DHW (l/h)	KW	DHW (l/h)	KW	DHW (l/h)
MVV-1500-SSB	3	59	1016	87	1499	115	1981
	5	72	1240	108	1860	143	2463
	8	85	1464	128	2205	168	2894
MVV-2000-SSB	3	68	1171	104	1791	137	2360
	5	86	1481	131	2256	174	2997
	8	102	1757	157	2704	209	3600
MVV-2500-SSB	3	76	1312	118	2040	157	2697
	5	96	1654	151	2595	199	3429
	8	114	1969	180	3107	238	4103
MVV-3000-SSB	3	100	1722	155	2670	208	3583
	5	127	2188	198	3411	268	4616
	8	151	2601	238	4100	323	5564
MVV-3500-SSB	3	100	1722	155	2670	208	3583
	5	127	2188	198	3411	268	4616
	8	151	2601	238	4100	323	5564
MVV-4000-SSB	3	100	1722	155	2670	208	3583
	5	127	2188	198	3411	268	4616
	8	151	2601	238	4100	323	5564
MVV-5000-SSB	3	113	1948	179	3077	238	4094
	5	144	2477	232	3992	312	5368
	8	172	2964	281	4833	380	6540
MVV-6000-SSB	3	113	1948	179	3077	238	4094
	5	144	2477	232	3992	312	5368
	8	172	2964	281	4833	380	6540

MASTER VITRO - UPPER COIL⁽¹⁾ - S2B / SS2B [Continuous flow DHW production (liters/hour) 10°C - 45°C]

PRIMARY INPUT TEMPERATURE °C		55 °C		70 °C		80 °C		90 °C	
tank model	primary pump flow (m ³ /h)	KW	DHW (l/h)	KW	DHW (l/h)	KW	DHW (l/h)	KW	DHW (l/h)
MVV-2000-S2B/SS2B	3	36	886	70	1722	92	2264	115	2830
	5	42	1033	83	2042	110	2707	136	3347
	8	48	1181	95	2338	127	3125	155	3814
MVV-3500-S2B/SS2B	3	50	1230	92	2264	119	2928	147	3617
	5	60	1476	112	2756	145	3568	179	4405
	8	69	1698	131	3224	169	4159	208	5118
MVV-5000-S2B/SS2B	3	58	1427	103	2535	136	3347	168	4134
	5	71	1747	129	3174	170	4183	210	5167
	8	82	2018	152	3740	202	4971	250	6152

(1) DHW productions for the lower coils of S2B models correspond to the productions of the SB models, see page 102.

MASTER VITRO - UPPER COIL⁽²⁾ - S2B / SS2B [Continuous flow DHW production (liters/hour) 10°C - 60°C]

PRIMARY INPUT TEMPERATURE °C		70 °C		80 °C		90 °C	
tank model	primary pump flow (m ³ /h)	KW	DHW (l/h)	KW	DHW (l/h)	KW	DHW (l/h)
MVV-2000-S2B/SS2B	3	43	741	67	1154	88	1516
	5	53	913	82	1412	108	1860
	8	62	1068	96	1654	126	2170
MVV-3500-S2B/SS2B	3	58	999	86	1481	114	1964
	5	72	1240	106	1826	141	2429
	8	84	1447	125	2153	165	2842
MVV-5000-S2B/SS2B	3	66	1137	100	1722	132	2274
	5	83	1430	125	2153	167	2877
	8	98	1688	150	2584	199	3428

(2) DHW productions for the lower coils of SS2B models correspond to the productions of the SSB models, see page 103.

MASTER VITRO - COILS models - SB - (DHW production - peak flow -)

		MVV1500 SB	MVV2000 SB	MVV2500 SB	MVV3000 SB	MVV3500 SB	MVV4000 SB	MVV5000 SB	MVV6000 SB
Peak flow 40°C	L/10'	2925	3900	4875	5850	6825	7800	9750	11800
Peak flow 45°C	L/10'	2500	3325	4175	5000	5850	6675	8350	10050
Peak flow 60°C	L/10'	1750	2325	2925	3500	4075	4675	5850	7075
Peak flow 40°C	L/60'	6675	8150	9625	11675	14240	15200	18500	20550
Peak flow 45°C	L/60'	5600	6850	8125	9825	12055	12875	15625	17340
Peak flow 60°C	L/60'	3400	4225	5050	6125	7450	8000	9750	10990
Continuous flow 40°C	Ltrs/h	4500	5100	5700	7000	8900	8900	10500	10500
Continuous flow 45°C	Ltrs/h	3725	4250	4750	5800	7450	7450	8750	8750
Continuous flow 60°C	Ltrs/h	2000	2300	2550	3150	4000	4000	4700	4700
Heating time (from 10 to 75°C)	Min	77	88	100	97	100	102	109	117
Primary flow	m³/h	8	8	8	8	8	8	8	8

Primary input temperature 85°C

MASTER VITRO - COILS models - SSB - (DHW production - peak flow -)

		MVV1500 SSB	MVV2000 SSB	MVV2500 SSB	MVV3000 SSB	MVV3500 SSB	MVV4000 SSB	MVV5000 SSB	MVV6000 SSB
Peak flow 40°C	L/10'	2925	3900	4875	5850	6825	7800	9750	11775
Peak flow 45°C	L/10'	2500	3325	4175	5000	5850	6675	8350	10370
Peak flow 60°C	L/10'	1750	2325	2925	3500	4075	4675	5850	7150
Peak flow 40°C	L/60'	7675	9725	11550	14600	15575	16550	18900	20940
Peak flow 45°C	L/60'	6450	8150	9735	12275	13125	13950	16000	18040
Peak flow 60°C	L/60'	3875	4950	5930	7400	7975	8575	10000	11320
Continuous flow 40°C	Ltrs/h	5700	7000	8010	10500	10500	10500	11000	11000
Continuous flow 45°C	Ltrs/h	4750	5800	6675	8750	8750	8750	9200	9200
Continuous flow 60°C	Ltrs/h	2550	3150	3605	4700	4700	4700	5000	5000
Heating time (from 10 to 75°C)	Min	60	65	65	65	76	87	102	110
Primary flow	m³/h	8	8	8	8	8	8	8	8

Primary input temperature 85°C

MASTER VITRO - COILS models - S2B / SS2B - (DHW production - peak flow -)

LOWER COIL		MVV2000 S2B	MVV3500 S2B	MVV5000 S2B	MVV6000 S2B	MVV2000 SS2B	MVV3500 SS2B	MVV5000 SS2B	MVV6000 SS2B
Peak flow 40°C	L/10'	3900	6825	10840	12790	3900	6825	10840	12790
Peak flow 45°C	L/10'	3325	5850	9235	10910	3325	5850	9235	10910
Peak flow 60°C	L/10'	2325	4075	6325	7500	2325	4075	6325	7500
Peak flow 40°C	L/60'	8150	14240	21740	23690	9725	15575	21740	23690
Peak flow 45°C	L/60'	6850	12055	18010	19680	8150	13125	18010	19680
Peak flow 60°C	L/60'	4225	7405	11065	12240	4950	7975	11065	12240
Continuous flow 40°C	Ltrs/h	5100	8900	13080	13080	7000	10500	13080	13080
Continuous flow 45°C	Ltrs/h	4250	7450	10530	10530	5800	8750	10530	10530
Continuous flow 60°C	Ltrs/h	2300	4000	5690	5690	3150	4700	5690	5690
Heating time (from 10 to 75°C)	Min	88	98	102	110	65	76	102	110
Primary flow	m³/h	8	8	8	8	8	8	8	8

Primary input temperature 85°C



The MASTER VITRO models can be fitted with electric heating elements:

- "RB/EB" STORAGE models:
MAIN ELECTRIC HEATING
and/or BACKUP ELECTRIC HEATING
- Models with "SB/SSB" COILS :
BACK-UP ELECTRIC HEATING

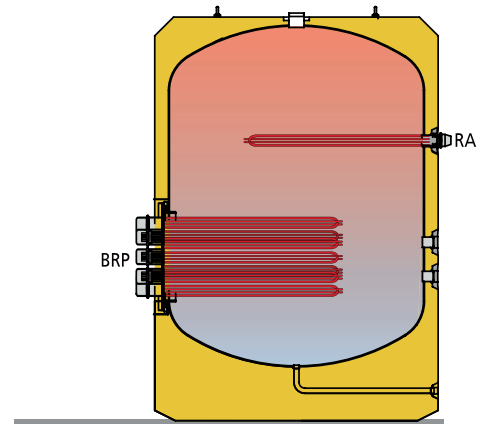

MASTER "VITRO" threaded immersion heating elements, in INCOLOY, for electric heating:

Electric heating element model	KW	V	Thread	Integrated control	IP	Length L*	MAIN HEATING and/or BACKUP HEATING	BACKUPHEATING
RA4/2-60H	6,0	230/400	2" M	-	40	797	MVV1500-...6000-RB/EB	MVV1500-...6000-SB/SSB
RA4/2-90H	9,0	230/400	2" M	-	40	1115	MVV1500-...6000-RB/EB	MVV1500-...6000-SB/SSB
RA4/2-120DH	12,0	230/400	2" M	-	40	680	MVV1500-...6000-RB/EB	MVV1500-...6000-SB/SSB
RA4/2-120DHT	12,0	230/401	2" M	Regulation and safety thermostat*	65	680	MVV1500-...6000-RB/EB	MVV1500-...6000-SB/SSB
RA4/2-125DHT	12,5	230/400	2" M	Regulation and safety thermostat*	65	680	MVV1500-...6000-RB/EB	MVV1500-...6000-SB/SSB
RA4/2-150DH	15,0	230/400	2" M	-	40	820	MVV1500-...6000-RB/EB	MVV1500-...6000-SB/SSB
RA4/2-150DHT	15,0	230/400	2" M	Regulation and safety thermostat*	65	820	MVV1500-...6000-RB/EB	MVV1500-...6000-SB/SSB
RA4/2-250DH	25,0	230/400	2" M	-	40	1200	MVV1500-...6000-RB/EB	MVV1500-...6000-SB/SSB
RA4/2-250DHT	25,0	230/400	2" M	Regulation and safety thermostat*	65	1200	MVV1500-...6000-RB/EB	MVV1500-...6000-SB/SSB



(*) Regulation thermostat: 0 - 75°C (adjusted to 60 °C) / Safety thermostat: 90 °C

HIGH ELECTRIC POWERS:

If high electric power storage tanks have to be installed, the electric heating elements can be grouped together in the ND400 manhole. The "RB" models can be fitted with up to 8 immersion elements in the ND400 side manhole, to obtain a maximum power of 200 KW. For the 2000, 3500, 5000 and 6000 litre models an optional second ND400 manhole can be included to group together up to 16 electric heating elements, for a maximum power of 400 KW.

SPECIAL MANUFACTURE: The "SB" and "SSB" models can only incorporate electric heating elements in the ND400 if it is moved to the top part of the storage tank, above the set of coils. In this case the electric heating would act as backup heating. As an option, the 2000, 3500, 5000 and 6000 litre models can also include a second ND400.

In all of the cases the system is supplied with a protective box for the set of heating elements in stainless steel, with a lid.

MVV "RB" models with threaded immersion heating elements, in MH ND400

LOWER MANHOLE main heating		UPPER MANHOLE backup heating
Tank models MVV "RB"	Number of heating elements on MH ND400	Number of heating elements on MH ND400 (OPTIONAL)
MVV1500RB	3, 4, 5, 6, 7 u 8	-
MVV2000RB	3, 4, 5, 6, 7 u 8	3, 4, 5, 6, 7 u 8
MVV2500RB	3, 4, 5, 6, 7 u 8	-
MVV3000RB	3, 4, 5, 6, 7 u 8	-
MVV3500RB	3, 4, 5, 6, 7 u 8	3, 4, 5, 6, 7 u 8
MVV4000RB	3, 4, 5, 6, 7 u 8	-
MVV5000RB	3, 4, 5, 6, 7 u 8	3, 4, 5, 6, 7 u 8
MVV6000RB	3, 4, 5, 6, 7 u 8	3, 4, 5, 6, 7 u 8



MVV "SB/SSB" models with threaded immersion heating elements, in MH ND400

(ONLY BACKUP HEATING)

(OPTION 1) Manhole moved to top part of tank.

(OPTION 2) Second manhole on top part of tank

Tank models MVV "SB/SSB"	Number of heating elements on MH ND400 (OPTION 1)	Number of heating elements on 2nd MH ND400 (OPTION 2)
MVV1500SB/SSB	3, 4, 5, 6, 7 u 8	-
MVV2000SB/SSB	3, 4, 5, 6, 7 u 8	3, 4, 5, 6, 7 u 8
MVV2500SB/SSB	3, 4, 5, 6, 7 u 8	-
MVV3000SB/SSB	3, 4, 5, 6, 7 u 8	-
MVV3500SB/SSB	3, 4, 5, 6, 7 u 8	3, 4, 5, 6, 7 u 8
MVV4000SB/SSB	3, 4, 5, 6, 7 u 8	-
MVV5000SB/SSB	3, 4, 5, 6, 7 u 8	3, 4, 5, 6, 7 u 8
MVV6000SB/SSB	3, 4, 5, 6, 7 u 8	3, 4, 5, 6, 7 u 8



MASTER "VITRO" sheathed CERAMIC HEATING ELEMENTS on stainless steel plate for MH ND400

ND400 stainless steel plate with sheaths for ceramic heating elements + no. of heating elements selected. NUMBER OF HEATING ELEMENTS per plate in MH ND400: 3, 4, 5, 6, 7 or 8

Electric element model	KW	V	Length L*	Optional application on models MVV	
				MAIN and/or BACKUP HEATING	BACKUP HEATING
RCER-45	4,5	230/400	800	MVV1500-...6000-RB	MVV1500-...6000-SB/SSB
RCER-60	6,0	230/400	1000	MVV1500-...6000-RB	MVV1500-...6000-SB/SSB



ELECTRIC HEATING WITH CERAMIC HEATING ELEMENTS. "DRY" SYSTEM

With the "dry" system with ceramic electric heating elements there is no need to drain the storage tank when fitting/removing or replacing the heating elements.

This system consists of a ND400 stainless steel plate with blind sheaths in the same material that house the ceramic heating elements.

With a maximum of 8 units per ND400 plate, this system provides a maximum of 48 KW of electric power.

As an option, the storage tank can be equipped with a second ND400 manhole. In this case, maximum installable power would be 96 KW (only valid for 2000, 3500, 5000 and 6000 litre "RB" models).

In all of the cases the system is supplied with a protective box for the set of heating elements in stainless steel, with a lid.

MVV "RB" models with ceramic electric heating elements, in ND400 MANHOLE

LOWER MANHOLE main heating		UPPER MANHOLE backup heating
Tank models MVV "RB"	Number of heating elements on MH ND400	Number of heating elements on 2nd MH ND400 (OPTIONAL)
MVV1500RB	3, 4, 5, 6, 7 u 8	-
MVV2000RB	3, 4, 5, 6, 7 u 8	3, 4, 5, 6, 7 u 8
MVV2500RB	3, 4, 5, 6, 7 u 8	-
MVV3000RB	3, 4, 5, 6, 7 u 8	-
MVV3500RB	3, 4, 5, 6, 7 u 8	3, 4, 5, 6, 7 u 8
MVV4000RB	3, 4, 5, 6, 7 u 8	-
MVV5000RB	3, 4, 5, 6, 7 u 8	3, 4, 5, 6, 7 u 8
MVV6000RB	3, 4, 5, 6, 7 u 8	3, 4, 5, 6, 7 u 8



MVV "SB/SSB" models with ceramic electric heating elements, in ND400 MANHOLE

(BACKUP HEATING ONLY)

(OPTION 1) Manhole moved to top part of tank.

(OPTION 2) Second manhole on top part of tank

Tank models MVV "SB/SSB"	Number of heating elements on MH ND400 (OPTION 1)	Number of heating elements on 2nd MH ND400 (OPTION 2)
MVV1500SB/SSB	3, 4, 5, 6, 7 u 8	-
MVV2000SB/SSB	3, 4, 5, 6, 7 u 8	3, 4, 5, 6, 7 u 8
MVV2500SB/SSB	3, 4, 5, 6, 7 u 8	-
MVV3000SB/SSB	3, 4, 5, 6, 7 u 8	-
MVV3500SB/SSB	3, 4, 5, 6, 7 u 8	3, 4, 5, 6, 7 u 8
MVV4000SB/SSB	3, 4, 5, 6, 7 u 8	-
MVV5000SB/SSB	3, 4, 5, 6, 7 u 8	3, 4, 5, 6, 7 u 8
MVV6000SB/SSB	3, 4, 5, 6, 7 u 8	3, 4, 5, 6, 7 u 8



In all of the cases the system is supplied with a protective box for the set of heating elements in stainless steel, with a lid..



The "MASTER VITRO" series of tanks are thermally insulated at the factory by direct mould-injection with PU material CFC- and HCFC-free. This system guarantees a perfectly regular insulation thickness with optimum material density. The thicknesses indicated in the table refer to the circular tank body, but the insulation is much thicker on the top part (up to four times greater). Because the top zone of the tank has better thermal protection, heat losses are much lower than those specified by the most stringent regulations, such as the DIN 4753/8 standard.



Rigid, mould-injected PU insulating material.

- *Minimal heat loss!*
- *For hot and cold water!*
- *No condensation on tank body!*
- *Compact block, no joints!*

TABLE OF THERMAL INSULATION: MASTER VITRO SERIES

Serie	Type	Model	Thermal insulation k= 0.025 W/m °K	Insulation thickness PU (mm.)	Static heat losses EN 12897 (W)	ErP  (EU 812/2013)	Minimum thickness of equivalent insulation with other insulating materials (mm)		
							Flexible polyurethane foam* k= 0,040 W/m °K	Rockwool* k= 0,034 - 0,042 W/m °K	Fiberglass* k= 0,035 - 0,046 W/m °K
MASTER VITRO	COIL STORAGE	MVV-1500-RB/SB/SSB	PU	80	154	C	130	110 - 140	115 - 155
MASTER VITRO		MVV-2000-RB/SB/SSB/S2B/SS2B	PU	80	174	C	130	110 - 140	115 - 155
MASTER VITRO		MVV-2500-RB/SB/SSB	PU	80	194	C	130	110 - 140	115 - 155
MASTER VITRO		MVV-3000-RB/SB/SSB	PU	80	215	C	130	110 - 140	115 - 155
MASTER VITRO		MVV-3500-RB/SB/SSB/S2B/SS2B	PU	80	232	C	130	110 - 140	115 - 155
MASTER VITRO		MVV-4000-RB/SB/SSB	PU	80	245	C	130	110 - 140	115 - 155
MASTER VITRO		MVV-5000-RB/SB/SSB/S2B/SS2B	PU	80	266	C	130	110 - 140	115 - 155
MASTER VITRO		MVV-6000-RB/SB/SSB/S2B/SS2B	PU	80	280	C	130	110 - 140	115 - 155

(*) Detachable systems can lose up to 25% of the insulating capacity overall, so that in that case the insulation thickness will increased proportionally.



"LAPESA CORREX-UP" PERMANENT CATHODIC PROTECTION SYSTEM.

MASTER VITRO tanks include a "lapesa correx-up" cathodic protection unit as a **standard feature**.

Totally automatic! "lapesa correx-up", cathodic protection system comprises special titanium anodes that emit the necessary current for the metal surface to be protected by means of an automatic potentiostat connect to the mains power supply.

Maintenance free! This cathodic protection system is permanent which means that, unlike sacrificial anodes, there is no wear and the anodes do not need to be replaced.

All DHW tanks made of carbon steel with an inner lining should be equipped with the cathodic protection system (DIN 4753)

KIT C.P. lapesa correx-up	Applicable to MASTER VITRO tanks models
KITPCTIMV1A	MVV-1500/2000-RB/SB/SSB/EB
KITPCTIMV2A	MVV-2500...5000-RB/SB/SSB/EB

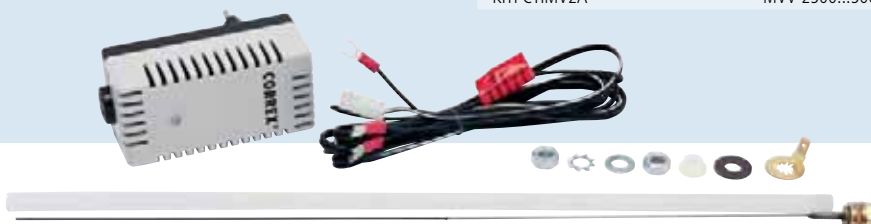

"lapesa correx-up" permanent cathodic protection system: Maintenance-free permanent cathodic protection unit. These anodes do not wear out and they emit the necessary electric current automatically providing the tank with cathodic protection via an individual potentiostat for each anode, connected to the mains electricity.

STANDARD CATHODIC PROTECTION SYSTEM IN "MASTER VITRO" SERIES.

Optional in all "MASTER VITRO" models.



Cathodic protection units differ in terms of size and number of sacrificial Magnesium anodes depending on the model, the geometry and the capacity of the "MASTER VITRO" storage tank.



ACCESSORIES - MASTER VITRO



EXTERNAL LINING

External lining for "MASTER VITRO" tanks with top cover, ND400 side manhole cover and trims for hydraulic connections. Standard external lining: GREY / RAL 7042.

Capacity (l)	Standard (KIT reference)	Fireproof (KIT reference)	Weatherproof (KIT reference)
1500	FME1500	FME1500/MO	FME1500/EX
2000	FME2000	FME2000/MO	FME2000/EX
2500	FME2500	FME2500/MO	FME2500/EX
3000	FME3000	FME3000/MO	FME3000/EX
3500	FME3500	FME3500/MO	FME3500/EX
4000	FME4000	FME4000/MO	FME4000/EX
5000	FME5000	FME5000/MO	FME5000/EX
6000	FME6000	FME6000/MO	FME6000/EX

ALUNOX EXTERNAL LINING

External aluminium sheet lining. ALUNOX external lining is supplied ready-mounted on the tank, over the PU insulation.

Capacity (l)	Aluminium lining ALUNOX - Ref.
1500	FME1500/ALUNOX-B
2000	FME2000/ALUNOX-B
2500	FME2500/ALUNOX-B
3000	FME3000/ALUNOX-B
3500	FME3500/ALUNOX-B
4000	FME4000/ALUNOX-B
5000	FME5000/ALUNOX-B





2" M THREADED ELECTRIC HEATING ELEMENT.

Low charge density, threaded, immersion electric element in Incoloy for "MASTER VITRO" STORAGE and COIL tanks.

Characteristics and powers: page: 108 -ELECTRIC HEATING-

Electric element model	KW	V	Thread	Integrated control
RA4/2-60	6,0	230/400	2" M	-
RA4/2-90	9,0	230/400	2" M	-
RA4/2-120D	12,0	230/400	2" M	-
RA4/2-120DT	12,0	230/401	2" M	Regulation and safety thermostat
RA4/2-125DT	12,5	230/400	2" M	Regulation and safety thermostat
RA4/2-150D	15,0	230/400	2" M	-
RA4/2-150DT	15,0	230/400	2" M	Regulation and safety thermostat
RA4/2-250D	25,0	230/400	2" M	-
RA4/2-250DT	25,0	230/400	2" M	Regulation and safety thermostat

(*) Regulation thermostat 0 -75 °C (adjusted to 60 °C) / Safety thermostat 90 °C

CERAMIC ELECTRIC HEATING ELEMENT, STORAGE AND COIL MODELS.

Sheathed ceramic electric heating element for "MASTER VITRO" STORAGE and COIL tanks, models "RB"

Characteristics and powers: page: 106 -ELECTRIC HEATING-

Electric element model	KW	V
RCER-45	4,5	230/400
RCER-60	6,0	230/400



ND 400 PLATES FOR INSTALLATION OF ELECTRIC HEATING ELEMENTS IN ND400 SIDE MANHOLE.

ND 400 plate and protective hood in stainless steel, with 2" threaded connections to install immersion electric heating elements in ND400 side manhole.

ND400 plate set

TBH2CONEX
TBH4CONEX
TBH5CONEX
TBH6CONEX
TBH7CONEX
TBH8CONEX

(*) Heating elements not included



ND 400 PLATES FOR INSTALLATION OF ELECTRIC HEATING ELEMENTS IN ND400 SIDE MANHOLE.

ND 400 plate and protective hood in stainless steel, for installation of sheathed ceramic electrical heating elements ("dry" system) in ND400 side manhole.

ND400 plate set

TBH2VAINAS
TBH4VAINAS
TBH5VAINAS
TBH6VAINAS
TBH7VAINAS
TBH8VAINAS

(*) Heating elements not included

DUAL CONTROL AND SAFETY THERMOSTAT

Kit comprising dual control 0-75°C (set at 60°C) and safety (95°C) thermostat, with 1/2" x 100 mm threaded sheath and 3/4"-1/2" reduction

KIT

KIT MASTER double thermostat



0-120°C THERMOMETER

KIT comprising 0-120°C thermometer with 1/2" x 100 mm threaded sheath and 3/4"-1/2" reduction

KIT

KIT pressure gauge

0-16 BAR PRESSURE GAUGE

KIT comprising 0-16 bar pressure gauge with 3/4"-1/2" reduction and 1/2"-1/4" reduction

KIT

KIT pressure gauge



P & T PRESSURE AND TEMPERATURE SAFETY VALVE

P & T pressure and temperature safety valve, 8 bar, 92°C

KIT

3/4" P&T valve KIT
1 1/4" P&T valve KIT

PLATE EXCHANGERS

COMPACT PLATE EXCHANGERS		Ref.	Number of plates	Flow rate at 50°C (l/h)	Power (kW) ⁽³⁾	Pressure drop (meters H ₂ O)	A x B x F mm	E mm	C mm	D mm	Connections
Max. working temperature	135 / 155°C ⁽¹⁾	LPIC-01	20	1.000	45	< 3	73 x 192 x 42,32	20,1	40	154	3/4"
Max working pressure	16 / 25 bar ⁽²⁾	LPIC-02	20	2.000	90	< 6	73 x 315 x 42,32	20,1	40	278	3/4"
Applications	Fluid/Fluid	LPIC-03	20	3.000	140	< 6	119 x 289 x 48,8	45	72	243	1"
Chassis	AISI 316	LPIC-04	30	4.000	185	< 6	119 x 289 x 71,2	45	72	243	1"
Plates	AISI 316	LPIC-05	40	5.000	235	< 6	119 x 289 x 93,6	45	72	243	1"
Connections	AISI 316	LPIC-07	40	7.000	325	< 8	119 x 376 x 93,6	45	63	320	1-1/4"
Additional features	Thermal Insulation	LPIC-10	60	10.000	465	< 8	119 x 376 x 136,4	45	63	320	1-1/4"
		LPIC-12	70	12.000	560	< 8	119 x 376 x 160,8	45	63	320	1-1/4"

(1) Maximum working temperature for LPIC-01 and LPIC-02 models 135°C, for rest of models 155°C

(2) Maximum working pressure for LPIC-01 and LPIC-02 models 16 bar, for rest of models 25 bar

(3) Power defined according to: Primary 90/60°C and secondary 10/50°C

Optional: Other pressures, temperatures or fluids

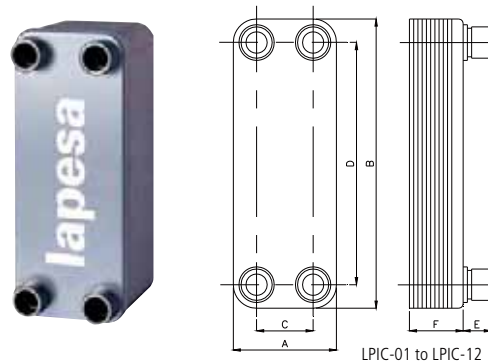

LPIC-01 to LPIC-12

DETTACHABLE PLATE EXCHANGERS		Ref.	Number of plates	Flow rate at 50°C (l/h)	Power (kW) ⁽³⁾	Pressure drop (meters H ₂ O)	A x C x F mm	E(max) mm	B mm	D mm	H mm	G mm
Max. working temperature	110°C	LPID-00	5	1.000	48	< 3	204 x 490 x 13,25	290	86	381	-	1-1/4"
Max. working pressure	10 bar	LPID-01	7	1.300	60	< 3	204 x 490 x 18,55	290	86	381	-	1-1/4"
Applications	Fluid/Fluid	LPID-02	11	2.600	120	< 3	204 x 490 x 29,15	290	86	381	-	1-1/4"
Chassis	Carbon steel	LPID-03	13	3.200	148	< 3	204 x 490 x 34,45	290	86	381	-	1-1/4"
Plates	AISI 316	LPID-04	17	4.200	195	< 3	204 x 490 x 45,05	290	86	381	-	1-1/4"
Connections	AISI 316	LPID-05	21	5.200	240	< 3	204 x 490 x 55,65	290	86	381	-	1-1/4"
Gaskets	EPDM	LPID-07	27	6.600	305	< 3	204 x 490 x 71,55	290	86	381	-	1-1/4"
Additional features	Thermal Insulation Support leg ⁽⁴⁾	LPID-10	37	8.600	400	< 3	204 x 490 x 98,05	290	86	381	-	1-1/4"
		LPID-12	45	10.000	465	< 3	204 x 490 x 119,25	290	86	381	-	1-1/4"
		LPID-21	23	15.700	725	< 3	312 x 963 x 80,5	960	140	690	185	2"
		LPID-22	29	20.500	950	< 3	312 x 963 x 101,5	960	140	690	185	2"
		LPID-23	35	25.000	1155	< 3	312 x 963 x 122,5	960	140	690	185	2"

(3) Power defined according to: Primary 90/60°C and secondary 10/50°C

(4) For models LPID-00 to LPID-12

Optional: Other pressures, temperatures or fluids

Chassis and plates in AISI-304, AISI-316 or Titanium

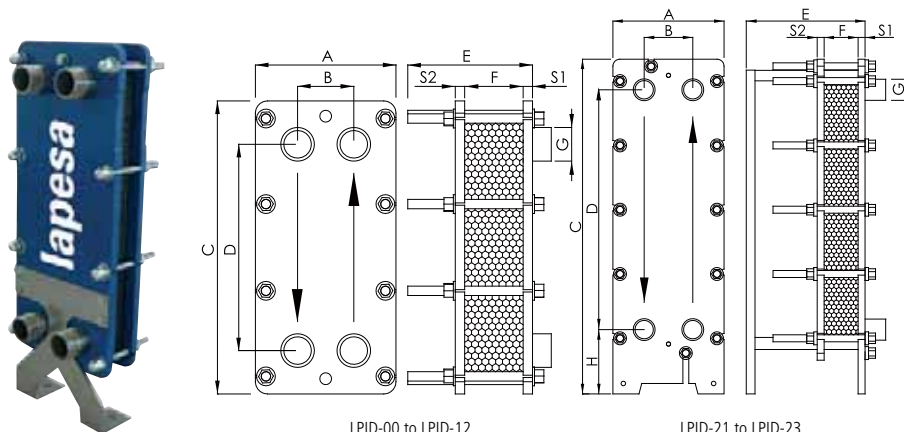

LPID-00 to LPID-12

LPID-21 to LPID-23

DATA REQUIRED TO PROVIDE A QUOTE FOR A CUSTOM PLATE EXCHANGER

To provide a specific offer of the most suitable plate heat exchanger for each particular case, the following details on the primary and secondary circuits are required:

- Primary and secondary circuit flows
- Input/output temperatures of the primary and secondary circuits
- Physical properties of the liquids (if they are neither water nor steam), density and specific heat.
- Required working pressure
- Pressure drop



GEISER INERTIA / MASTER INERTIA energy storage!

*The **GEISER INERTIA** and **MASTER INERTIA** series of buffer tanks are designed for use exclusively in closed heating or cooling circuits. These storage tanks in carbon steel include all of the hydraulic connections required for energy storage or heat inertia installations and, especially for the application of **RENEWABLE ENERGIES** where energy storage is a key factor in the efficient operation of the system.*

APPLICATIONS

GEISER INERTIA (50 to 1500 litres):

- (Individual or battery installation)
- Installations with solar energy
- Installations with biomass boilers
- Installations with heat pumps
- Combined energy storage installations
- Cooling installations

MASTER INERTIA (1.500 to 6000 litres):

- (Individual or battery installation)
- Energy storage and distribution facilities
- Centralized thermal solar energy systems
- Centralized systems with heat pump
- Centralized systems with biomass boiler
- Centralized instant DHW production systems
- Centralized combined energy storage systems
- Cooling installations



ENERGY BUFFER TANKS

for installations that
require correct energy
management, especially for
systems that use
renewable energy
sources such as:

BIOMASS, HEAT PUMP or SOLAR ENERGY





GEISER / MASTER INERTIA

Inertia buffer tanks, energy storage!

Inertia buffer tanks for closed heating or cooling circuits that act as the installation energy regulator.

*Models with or without internal exchanger and models with own heat stratification system complete our range of **GEISER/MASTER INERTIA**, from 30 to 6000 litres storage capacity.*

PRIMARY BUFFER TANKS Energy buffer tanks from **30** to **6000** litres capacity, for closed heating or cooling circuits.

For installations that require correct energy management, especially for systems that use renewable energy sources such as: **BIOMASS, HEAT PUMP or SOLAR ENERGY.**

Designed to provide an extraordinary storage capacity that translates directly into real savings. The overdimensioned, rigid, mould-injected PU thermal insulation maintains the DHW storage temperature over long periods of time without requiring any additional energy input. This means less start-ups and adjustments of external energy sources, with less energy consumption and a more economical cost.

MODELS WITH COILS: Versions with heating coils as the intermediate thermal exchange system, for systems without their own heat exchanger.

Ready for installation with electric heating elements to provide back-up electric heating.



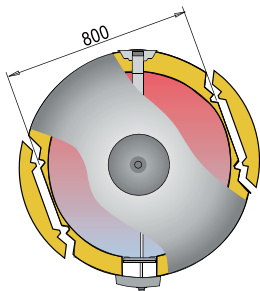
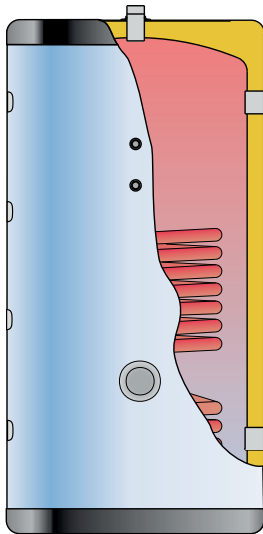

Detail of pre-cut insulation on 800 and 1000 litre tanks to pass through 800 mm wide doors.

MODELS WITH THERMAL STRATIFICATION SYSTEM: Versions that incorporate thermal stratification for perfect energy management of the installation.

MAXIMUM STORAGE CAPACITY: Extra thick, rigid, PU mould-injected insulation that minimizes heat losses of stored DHW (see HEAT INSULATION chapter, page: 126).

Lapesa buffer tanks have minimal heat losses and for this reason are considered to be one of the products with the greatest storage capacity on the market.

EASY TO INSTALL AND MAINTAIN: GEISER INERTIA 800 and 1000 litre models are designed with a detachable insulation system on the two opposite sides of the tank to allow them to pass through 800 mm wide accesses.

The MASTER INERTIA "IB" and "ISB" models include a ND400 side manhole to access the interior of the tank to carry out inspection, cleaning and maintenance tasks.

EASY TO HANDLE AND TRANSPORT: Our "MASTER INERTIA" buffer tanks are designed for easy handling and transport to the place of installation.

They have an integrated system for handling and transporting by forklift truck, which facilitates handling operations enormously, as there is no need to palletize the product which, given its weight and size, would make handling difficult.

The tanks are also equipped with lifting eyebolts on the top part so that if they have to be placed in a high area they can be lifted with an overhead hoist.



FEATURES COMMON TO ALL "GEISER INERTIA/MASTER INERTIA" MODELS:

- **Carbon steel** inertia buffer tank.
- GEISER INERTIA capacities: **30, 50, 80, 140, 200, 240, 370, 600, 800, 1000 and 1500 litres.**
- MASTER INERTIA capacities: **1500, 2000, 2500, 3000, 3500, 4000, 5000 and 6000 litres.**
- Maximum working pressure of buffer tank: **6 bar**
- Maximum working pressure, coil (models "IS" and "IFS"): **25 bar**
- Maximum working temperature of buffer tank: **110 °C**
- Maximum working temperature, coil (models "IS" and "IFS"): **200 °C**
- Thermal insulation: **Rigid, mould-injected PU** (CFC/HCFC-free, 0.025 W/m²K)
- Tanks for VERTICAL installation on floor (option of HORIZONTAL position - please consult us)

GEISER INERTIA "I / IF"

INERTIA buffer tanks from **30 to 1500** litres capacity, for closed heating or cooling circuits.
30, 50 and 80 litre models - for wall-mounting.

From 140 litre model onwards - for vertical installation on floor.

Ready for a backup electric immersion element to be fitted (up to 1000 litre model).

The 800 and 1000 litre capacity tanks include an insulation system that allows them to pass through 800 mm wide doors. Standard finish with RAL 5015 padded external lining and RAL 7021 grey cover (for model G-30-IF with white lining). For models of 1500 litre of capacity, set grey padded external lining RAL 7042 and black cover, supplied separately.

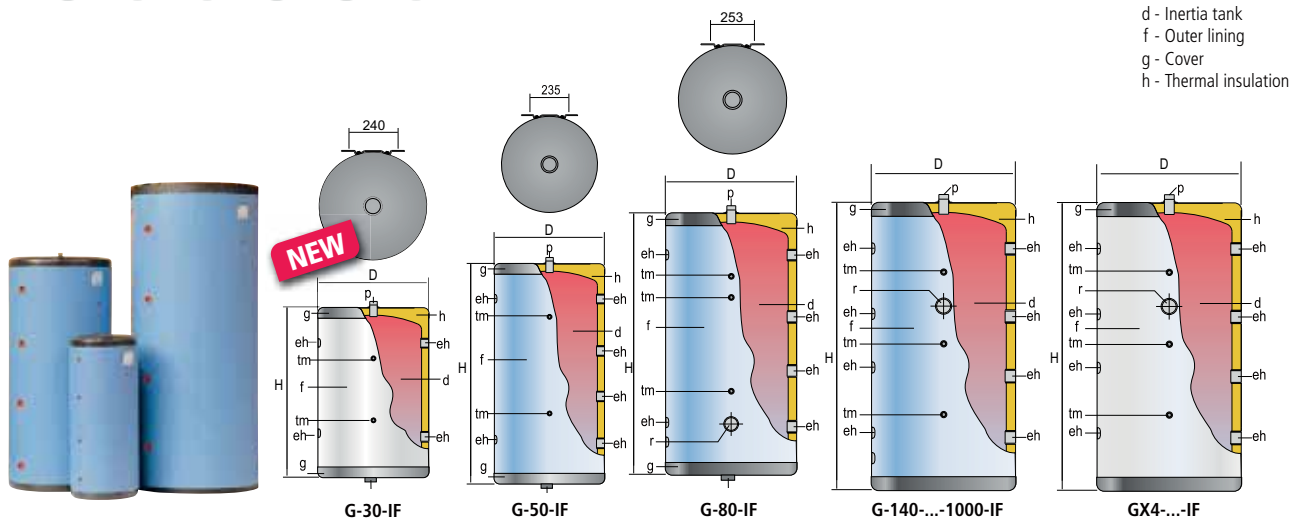

GENERAL CHARACTERISTICS							G-370-I	G-600-I	G-800-I	G-1000-I	G-1500-I	
CARBON STEEL	Capacity	l.						370	600	800	1000	1500
	D: external diameter	mm.						620	770	950	950	1160
	H: overall height	mm.						1725	1730	1840	2250	2320
	eh: side connection	" GAS/F						2	3	3	3	3
	p: upper connection	" GAS/M						1	1	1	1	1
	tm: probe tube connection for sensors	" GAS/F						1/2	1/2	1/2	1/2	1/2
Empty weight (approx.)	Kg						68	95	174	205	300	

GENERAL CHARACTERISTICS		G-30-IF	G-50-IF	G-80-IF	G-140-IF	G-200-IF	G-260-IF	G-370-IF	G-600-IF	G-800-IF	G-1000-IF	
CARBON STEEL	Capacity	l.	30	50	80	140	200	260	370	600	800	1000
	D: external diameter	mm.	380	380	480	480	620	620	620	770	950	950
	H: overall height	mm.	545	835	749	1155	985	1240	1725	1730	1840	2250
	eh: side connection	" GAS/F	1 1/4	1 1/4	1 1/4	1 1/4	1 1/2	1 1/2	1 1/2	1 1/2	1 1/2	1 1/2
	p: upper connection	" GAS	1/2 H	1/2 H	1/2 H	1M	1M	1M	1M	1M	1M	1M
	tm: probe tube connection for sensors	" GAS/F	1/2	1/2	1/2	1/2	1/2	1/2	1/2	1/2	1/2	1/2
	R: electric element connection	" GAS/F	-	-	2	2	2	2	2	2	2	2
Empty weight (approx.)	Kg	13	20	30	35	44	52	68	95	174	205	

GENERAL CHARACTERISTICS STAINLESS STEEL AISI 304		GX4-80-IF	GX4-140-IF	GX4-200-IF	GX4-260-IF	GX4-370-IF	GX4-500-IF	GX4-800-IF	GX4-1000-IF	
STAINLESS STEEL	Capacity	l.	80	140	200	260	370	500	800	1000
	D: external diameter	mm.	480	480	620	620	620	770	950	950
	H: overall height	mm.	749	1155	985	1240	1725	1730	1840	2250
	eh: side connection	" GAS/F	1 1/4	1 1/4	1 1/2	1 1/2	1 1/2	1 1/2	1 1/2	1 1/2
	p: upper connection	" GAS	1 H	1M	1M	1M	1M	1M	1M	1M
	tm: probe tube connection for sensors	" GAS/F	1/2	1/2	1/2	1/2	1/2	1/2	1/2	1/2
	R: electric element connection	" GAS/F	2	2	2	2	2	2	2	2
Empty weight (approx.)	Kg	22	25	32	38	50	70	128	150	

BUFFER TANKS FOR PRIMARY CIRCUITS MASTER INERTIA - STORAGE

MASTER INERTIA "I / IB"

INERTIA buffer tanks from **1500** to **6000** litres capacity, for closed heating or cooling circuits.

Ready to be fitted with a backup electric immersion element.

Thermally insulated with rigid, mould-injected, 80 mm-thick, PU polyurethane foam, with insulating piece in same material on the ND400 side manhole.

Optional supply of PVC padded external lining and set of trims or ALUNOX aluminium sheet lining (see ACCESSORIES chapter, page: 127).

IB MODELS: With side ND400 manhole to access inside the storage tank for inspection, cleaning and maintenance tasks.

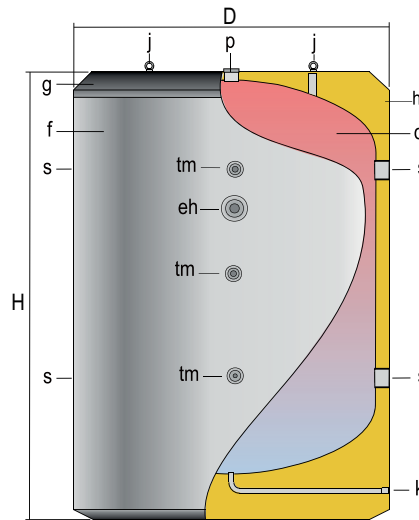

- d - Buffer tank
- f - Outer lining
- g - Top cover
- h - Thermal insulation
- j - Lifting eyebolts



CARBON STEEL

GENERAL CHARACTERISTICS		MV-1500 I/IB	MV-2000 I/IB	MV-2500 I/IB	MV-3000 I/IB	MV-3500 I/IB	MV-4000 I/IB	MV-5000 I/IB	MV-6000 IB
Capacity	l.	1500	2000	2500	3000	3500	4000	5000	6000
D: external diameter	mm.	1360	1360	1660	1660	1660	1910	1910	1910
H: overall height	mm.	1830	2280	2015	2305	2580	2310	2710	3210
Diagonal	mm.	2281	2655	2611	2841	3068	2998	3316	3735
s: side connection	" GAS/F	4	4	4	4	4	4	4	4
eh: electric element connection	" GAS/F	2	2	2	2	2	2	2	2
p: upper connection	" GAS/F	2	2	2	2	2	2	2	2
k: drain connection	" GAS/M	1 1/2	1 1/2	1 1/2	1 1/2	1 1/2	1 1/2	1 1/2	2
tm: probe tube connection for sensors	" GAS/F	1/2	1/2	1/2	1/2	1/2	1/2	1/2	1/2
Empty weight (approx.) "I / IB"	Kg	273 / 298	353 / 378	503 / 528	540 / 565	576 / 601	893 / 918	970 / 995	1090
Side hole (only in IB model)		DN400	DN400	DN400	DN400	DN400	DN400	DN400	DN400

STAINLESS STEEL

GENERAL CHARACTERISTICS STAINLESS STEEL AISI 304		MXV4-1500 I/IB	MXV4-2000 I/IB	MXV4-2500 I/IB	MXV4-3000 I/IB	MXV4-3500 I/IB	MXV4-4000 I/IB	MXV4-5000 I/IB	MXV4-6000 IB
Capacity	l.	1500	2000	2500	3000	3500	4000	5000	6000
D: external diameter	mm.	1360	1360	1660	1660	1660	1910	1910	1910
H: overall height	mm.	1830	2280	2015	2305	2580	2310	2710	3210
Diagonal	mm.	2281	2655	2611	2841	3068	2998	3316	3735
s: side connection	" GAS/F	4	4	4	4	4	4	4	4
eh: electric element connection	" GAS/F	2	2	2	2	2	2	2	2
p: upper connection	" GAS/F	2	2	2	2	2	2	2	2
k: drain connection	" GAS/M	1	1	1	1	1	1	1	1
tm: probe tube connection for sensors	" GAS/F	1/2	1/2	1/2	1/2	1/2	1/2	1/2	1/2
Empty weight (approx.) "I / IB"	Kg	273 / 298	353 / 378	503 / 528	540 / 565	576 / 601	893 / 918	970 / 995	1090
Side hole (only in IB model)		DN400	DN400	DN400	DN400	DN400	DN400	DN400	DN400

Note: The 6000 litre model includes support legs.

GEISER INERTIA "IS / IFS"

INERTIA buffer tanks, **260** to **1500** litre capacity, for closed heating or cooling circuits, with integrated intermediate heating **COIL**.

From 260 litre model onwards - for vertical installation on floor.

Ready to be fitted with a backup electric immersion element.

Up to 1000 litre model, standard finish with RAL 5015 blue padded external lining and RAL 7021 grey cover.

The 800 and 1000 litre capacity tanks include an insulation system that allows them to pass through 800 mm wide doors. External lining is optional for the 1500 litre model and is supplied separately (RAL 7042 grey external lining and black cover).

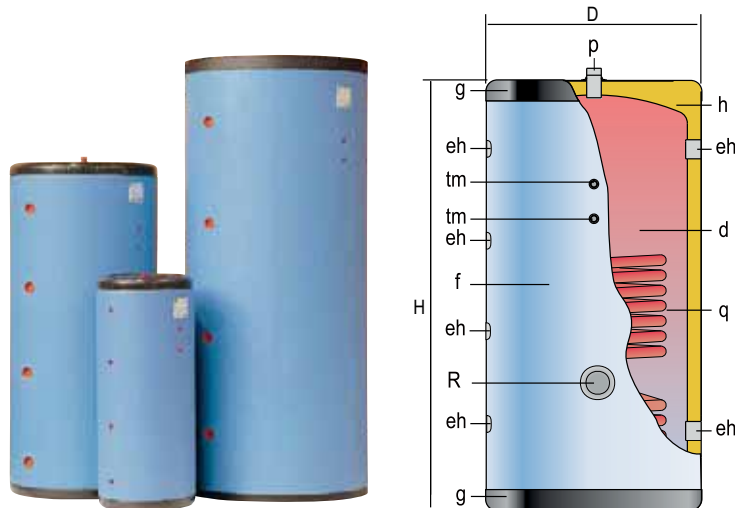

d - Buffer tank
f - Outer lining
g - Cover
h - Thermal insulation
q - Heating coil

GENERAL CHARACTERISTICS		G-370-IS	G-600-IS	G-800-IS	G-1000-IS	G-1500-IS
DHW capacity	l.	370	600	800	1000	1500
D: external diameter	mm.	620	770	950	950	1160
H: overall height	mm.	1725	1730	1840	2250	2320
eh: side connection	" GAS/F	2	3	3	3	3
p: upper connection	" GAS	1M	1M	1M	1M	1M
tm: probe tube connection for sensors	" GAS/F	1/2	1/2	1/2	1/2	1/2
R: electric element connection	" GAS/F	2	2	2	2	2
Heating coil surface	m ²	1,32	1,83	2,70	2,70	3,00
Empty weight (approx.)	Kg	86	123	199	231	339

GENERAL CHARACTERISTICS		G-260-IFS	G-370-IFS	G-600-IFS	G-800-IFS	G-1000-IFS	G-1500-IFS
DHW capacity	l.	260	370	600	800	1000	1500
D: external diameter	mm.	620	620	770	950	950	1160
H: overall height	mm.	1240	1725	1730	1840	2250	2320
eh: side connection	" GAS/F	1 1/2	1 1/2	1 1/2	1 1/2	1 1/2	1 1/2
p: upper connection	" GAS	1M	1M	1M	1M	1M	1M
tm: probe tube connection for sensors	" GAS/F	1/2	1/2	1/2	1/2	1/2	1/2
R: electric element connection	" GAS/F	2	2	2	2	2	2
Heating coil surface	m ²	1,32	1,32	1,83	2,70	2,70	3,00
Empty weight (approx.)	Kg	70	86	123	199	231	339

BUFFER TANKS FOR PRIMARY CIRCUITS

MASTER INERTIA - COIL

MASTER INERTIA "IS / ISB"

INERTIA buffer tanks, **1500 to 5000** litre capacity, for closed heating or cooling circuits, with integrated intermediate heating **COIL**.

Ready to be fitted with an electric immersion element for backup heating.

Thermally insulated with rigid, mould-injected, 80 mm-thick, PU polyurethane foam. Models ISB, with insulating piece in same material on the ND400 side manhole.

With side ND400 manhole to access the interior of the storage tank for inspection, cleaning and maintenance tasks.

Optional supply of PVC padded external lining and set of trims or ALUNOX aluminium sheet lining (see ACCESSORIES chapter, page: 127).

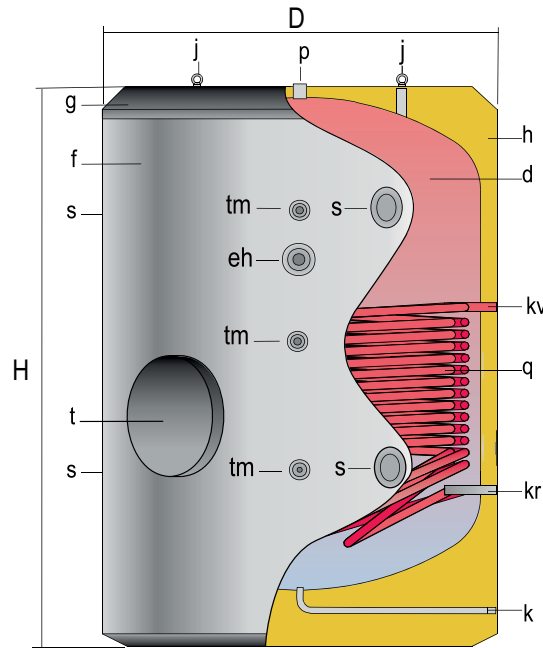

MV-1500-...5000-ISB

- d - Buffer tank
- f - Outer lining
- g - Top cover
- h - Thermal insulation
- j - Lifting eyes
- q - Coil
- t - Manhole ND400



GENERAL CHARACTERISTICS		MV-1500-IS	MV-2000-IS	MV-2500-IS	MV-3000-IS	MV-3500-IS	MV-4000-IS	MV-5000-IS
Capacity	l.	1500	2000	2500	3000	3500	4000	5000
D: external diameter	mm.	1360	1360	1660	1660	1660	1910	1910
H: overall height	mm.	1830	2280	2015	2305	2580	2310	2710
Diagonal	mm.	2281	2655	2611	2841	3068	2998	3316
s: side connection	" GAS/F	4	4	4	4	4	4	4
eh: electric element connectio	" GAS/F	2	2	2	2	2	2	2
p: upper connectionr	" GAS/F	2	2	2	2	2	2	2
k: drain connection	" GAS/M	1 1/2	1 1/2	1 1/2	1 1/2	1 1/2	1 1/2	1 1/2
tm: probe tube connection for sensors	" GAS/F	1/2	1/2	1/2	1/2	1/2	1/2	1/2
kv, kr: coil connections	" GAS/F	1	1	1	1	1	1	1
Heating coil surface	m ²	3,1	3,1	5,7	5,7	6,1	6,1	6,1
Empty weight (approx.) "IS / ISB"	Kg	344 / 369	388 / 423	565 / 590	601 / 626	640 / 665	953 / 978	1030 / 1055
Side hole (models "ISB")	DN	ND400	ND400	ND400	ND400	ND400	ND400	ND400



GEISER/MASTER INERTIA - STORAGE

INERTIA BUFFER TANKS with THERMAL STRATIFICATION energy management!

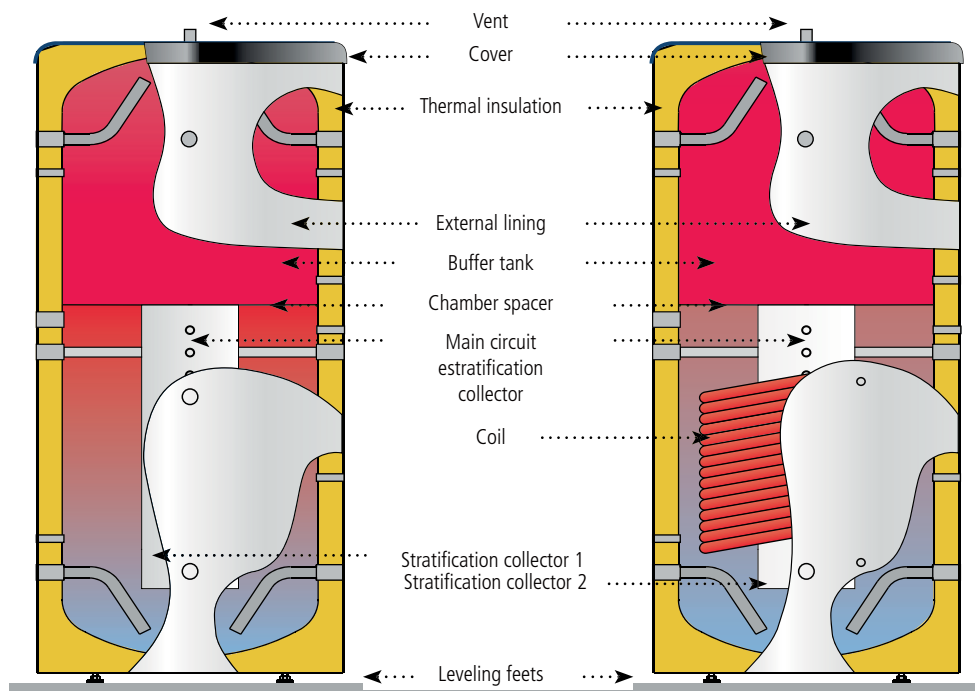

PRIMARY CIRCUIT BUFFER TANKS Energy buffer tanks from **800 to 5000** litres capacity, for closed heating circuits, with integrated **THERMAL STRATIFICATION** system.

For installations that require correct energy management, especially for systems that use renewable energy sources such as: **BIOMASS, HEAT PUMP or SOLAR ENERGY**, or several simultaneously combined energy sources.

Models with coil (LW) as the intermediate heat exchange system.

Designed to provide an extraordinary storage capacity that translates directly into real savings.

The overdimensioned, rigid, mould-injected PU thermal insulation maintains the DHW storage temperature over long periods of time without requiring any additional energy input. This means less start-ups and adjustments of external energy sources, with less energy consumption and a more economical cost.

THERMAL STRATIFICATION SYSTEM: Integrated thermal stratification system to install up to three different energy sources simultaneously. Three separate stratification collectors take the hot water returns to the corresponding temperature levels inside the buffer tank.

MULTIFUNCTIONAL: Stratification allows different water temperature levels to be used directly for different purposes. The top zone of the tank is kept at the maximum temperature for instant domestic hot water production or to heat radiators, whilst at the same time the water at a lower temperature can be used for underfloor heating systems.

MAXIMUM STORAGE CAPACITY: Extra thick, rigid, PU mould-injected insulation that minimizes heat losses of stored DHW (see HEAT INSULATION chapter, page: 126).

Lapesa buffer tanks have minimal heat losses and for this reason are considered to be one of the products with the greatest storage capacity on the market.

EASY TO HANDLE AND TRANSPORT: Our "MASTER INERTIA" buffer tanks are designed for easy handling and transport to the place of installation.

They have an integrated system for handling and transporting by forklift truck, which facilitates handling operations enormously, as there is no need to palletize the product which, given its weight and size, would make handling difficult. The tanks are also equipped with lifting eyebolts on the top part so that if they have to be placed in a high area they can be lifted with an overhead hoist. The 800 and 1000 litre models are designed with a detachable insulation system on the two opposite sides of the tank to allow them to pass through 800 mm wide accesses.



Thermal stratification of water stored in inertia buffer tanks allows correct management of energy, taking maximum advantage of it for each specific case and at the lowest economic cost!



FEATURES COMMON TO ALL MODELS:

"GEISER INERTIA / MASTER INERTIA STRATIFICATION":

- **Carbon steel** inertia buffer tanks.
- GEISER INERTIA capacities: **800, 1000 and 1500 litres.**
- MASTER INERTIA capacities: **2000, 2500, 3000, 3500, 4000 and 5000 litres.**
- Maximum working pressure of buffer tank: **6 bar**
- Maximum working pressure, coil ("LW" models): **25 bar**
- Maximum working temperature of buffer tank: **110 °C**
- Maximum working temperature, coil ("LW" models): **200 °C**
- Thermal insulation: **Rigid, mould-injected PU** (CFC/HCFC-free, 0.025 W/m²K)
- Tanks for **VERTICAL** installation on floor.

GEISER INERTIA "L"

INERTIA buffer tanks from **800** to **1500** litres capacity, for closed heating circuits, with integrated **THERMAL STRATIFICATION** system.

Tanks for VERTICAL installation on floor.

Up to 1000 litre model, standard finish with RAL 5015 blue padded external lining and RAL 7021 grey cover.

The 800 and 1000 litre capacity tanks include an insulation system that allows them to pass through 800 mm wide doors. Optional supply of aluminium sheet lining ALUNOX (see chapter ACCESSORIES, page: 127).

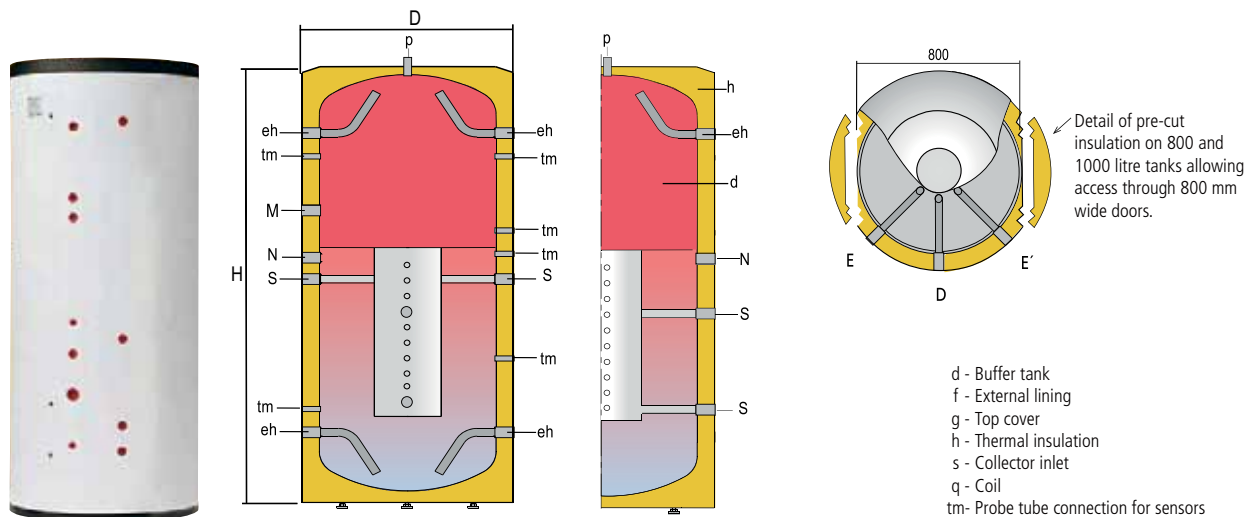

GENERAL CHARACTERISTICS		G-800-L	G-1000-L	G-1500-L
Capacity	l.	800	1000	1500
D: external diameter	mm.	950	950	1160
H: overall height	mm.	1840	2250	2320
eh: side connection	" GAS/F	1 1/2	1 1/2	1 1/2
R: side connection	" GAS/F	2	2	2
N: side connection	" GAS/F	1 1/2	1 1/2	1 1/2
p: upper connection	" GAS/F	3/4	3/4	3/4
tm: probe tube connection for sensors	" GAS/F	1/2	1/2	1/2
S: collector connection	" GAS/F	1 1/2	1 1/2	1 1/2
Empty weight (approx.)	Kg	175	200	260

GEISER INERTIA "LW"

INERTIA buffer tanks from **800 to 1500** litres capacity, for closed heating circuits, with integrated **THERMAL STRATIFICATION** system and **SOLAR COIL**.

Tanks for VERTICAL installation on floor.

Up to 1000 litre model, standard finish with RAL 5015 blue padded external lining and RAL 7021 grey cover.

The 800 and 1000 litre capacity tanks include an insulation system that allows them to pass through 800 mm wide doors. Optional supply of aluminium sheet lining ALUNOX (see chapter ACCESSORIES, page: 127).

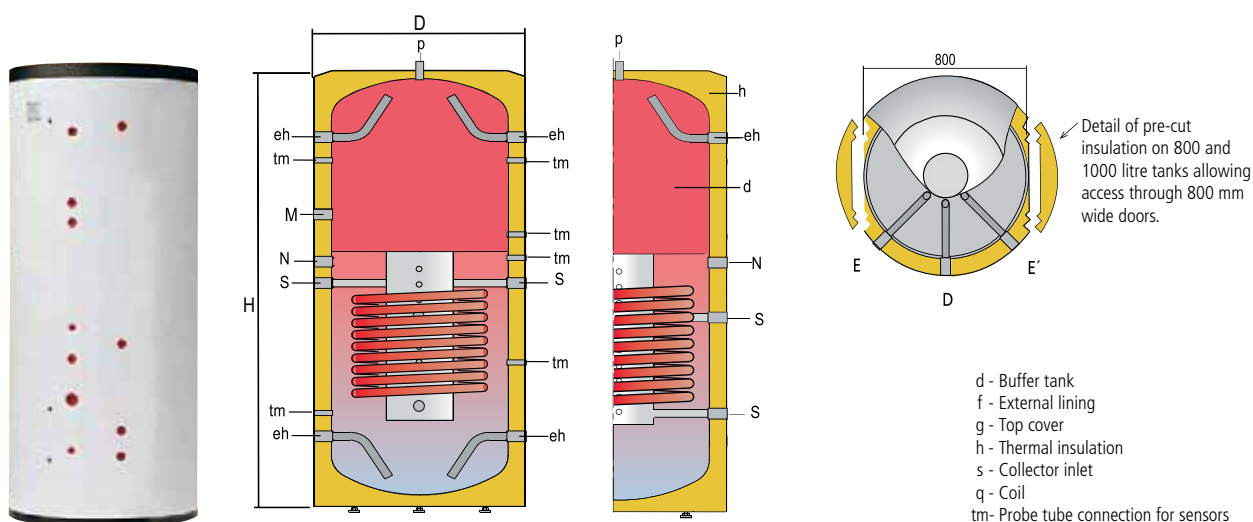

GENERAL CHARACTERISTICS		G-800-LW	G-1000-LW	G-1500-LW
Capacity	l.	800	1000	1500
D: external diameter	mm.	950	950	1160
H: overall height	mm.	1840	2250	2320
eh: side connection	" GAS/F	1 1/2	1 1/2	1 1/2
R: side connection	" GAS/F	2	2	2
N: side connection	" GAS/F	1 1/2	1 1/2	1 1/2
p: upper connection	" GAS/F	3/4	3/4	3/4
tm: probe tube connection for sensors	" GAS/F	1/2	1/2	1/2
S: collector connection	" GAS/F	1 1/2	1 1/2	1 1/2
sv, sr: coil connections	" GAS/F	1	1	1
Empty weight (approx.)	Kg	245	295	365

MASTER INERTIA "L"

INERTIA buffer tanks from **2000** to **5000** litres capacity, for closed heating circuits, with integrated **THERMAL STRATIFICATION** system.

Thermally insulated with rigid, mould-injected, 80 mm-thick, PU polyurethane foam.

Optional supply of PVC padded external lining and set of trims or ALUNOX aluminium sheet lining (see ACCESSORIES chapter, page: 127).

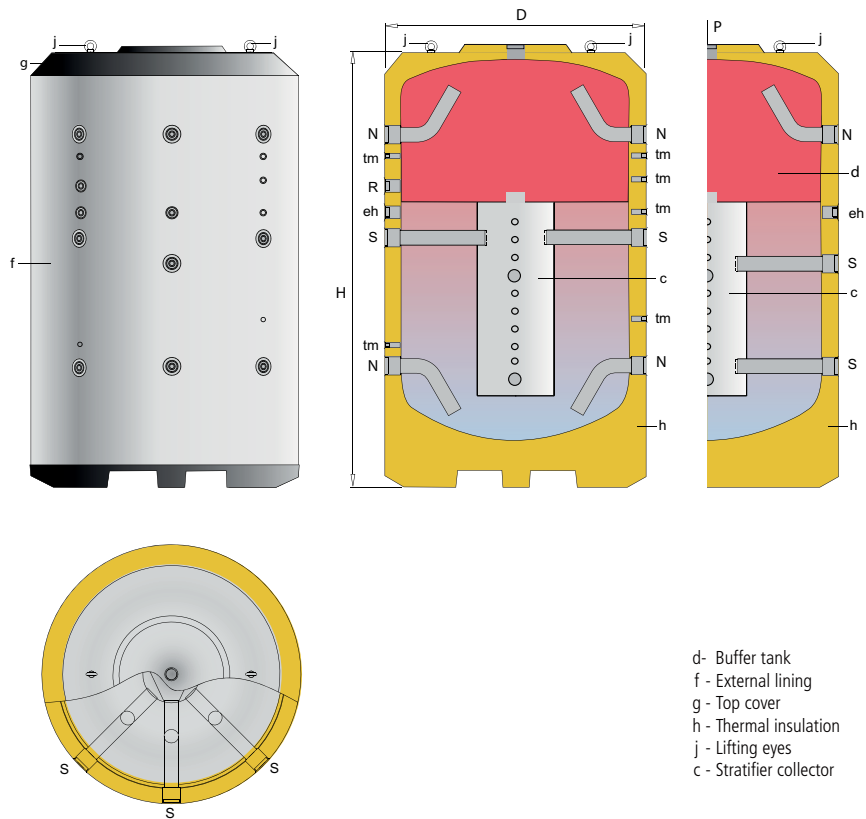

- d- Buffer tank
- f - External lining
- g - Top cover
- h - Thermal insulation
- j - Lifting eyes
- c - Stratifier collector

GENERAL CHARACTERISTICS		MV-2000-L	MV-3000-L	MV-4000-L	MV-5000-L
DHW capacity	l.	2000	3000	4000	5000
D: external diameter	mm.	1360	1660	1910	1910
H: overall height	mm.	2280	2305	2310	2710
Diagonal	mm.	2655	2841	2998	3316
eh: side connection	" GAS/F	2	2	2	2
R: side connection	" GAS/F	2	2	2	2
N: side connection	" GAS/F	3	3	3	3
p: upper connection	" GAS/F	2	2	2	2
tm: probe tube connection for sensors	" GAS/F	1/2	1/2	1/2	1/2
S: collector connection	" GAS/F	3	3	3	3
Empty weight (approx.)	Kg	428	616	965	1080

Thermal camera images comparing an "L" buffer tank with thermal stratification and a normal inertia model. Independent tests.

Inertia buffer tank (L) WITH integrated thermal stratification

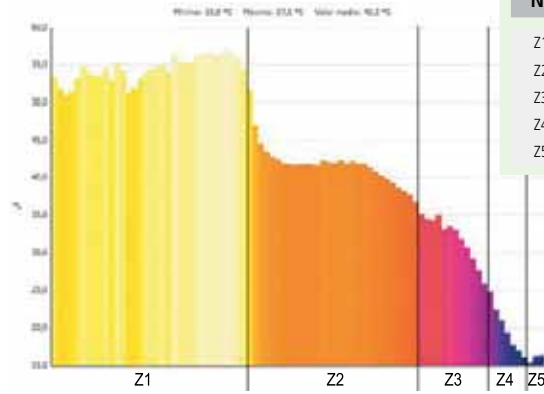
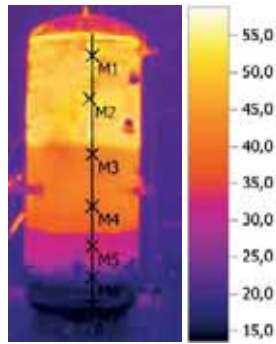
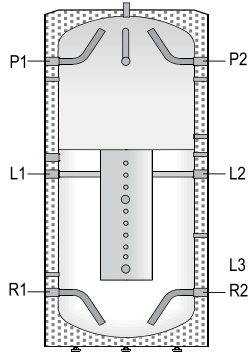

N°	Temp. (°C)	%
Z1	60,0	39
Z2	45,0	33
Z3	35,0	15
Z4	25,0	7
Z5	20,0	6

- Input of water to L2 tank: 40 °C
- Extraction of water from R1 tank: 15 °C
- Continuous flow during test: 500 l/h
- Volume of water during test: 140 litres

Inertia buffer tank WITHOUT integrated thermal stratification

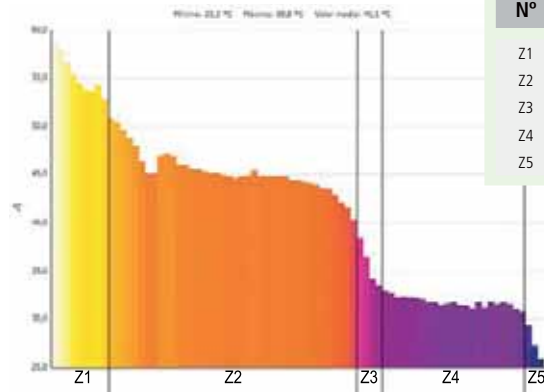
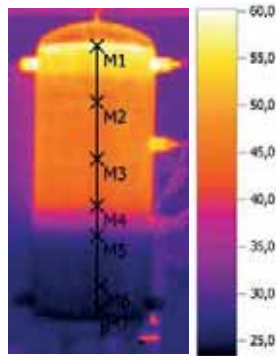
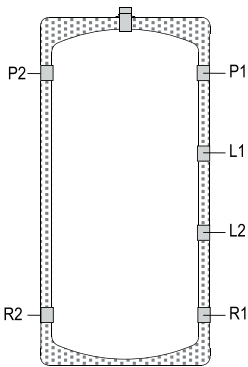

N°	Temp. (°C)	%
Z1	60,0	11
Z2	45,0	50
Z3	35,0	6
Z4	25,0	28
Z5	20,0	6

- Input of water to L2 tank: 40°C
- Extraction of water from R1 tank: 15°C
- Continuous flow during test: 500 l/h
- Volume of water during test: 140 litres

BUFFERING ENERGY CENTER (L)

Connection to DHW production system through plate heat exchanger or DHW tank.

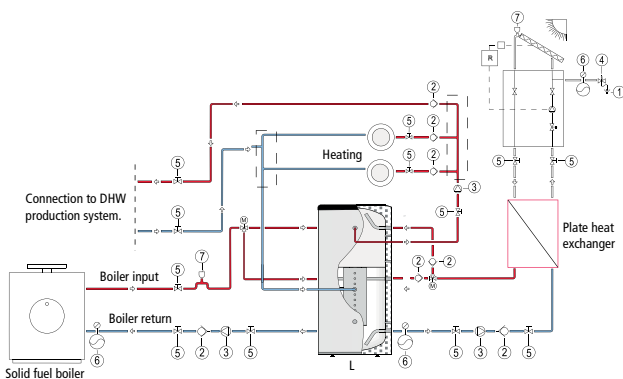

- 1 - Drain
- 2 - Non-return valve
- 3 - Pump
- 4 - Safety valve
- 5 - Shut-off valve
- 6 - Expansion vessel
- 7 - Vent

BUFFERING ENERGY CENTER (LW)

Connection to DHW production system through plate heat exchanger or DHW tank.

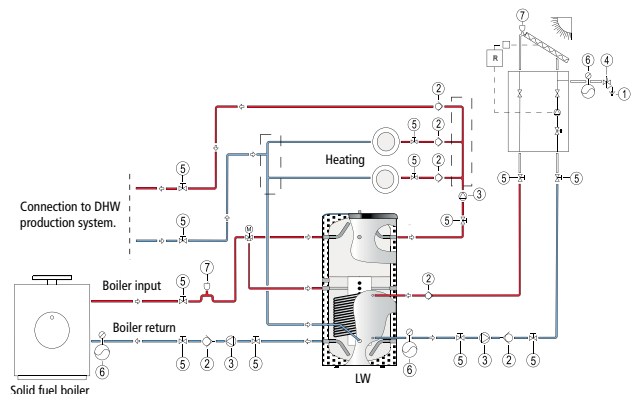

- 1 - Drain
- 2 - Non-return valve
- 3 - Pump
- 4 - Safety valve
- 5 - Shut-off valve
- 6 - Expansion vessel
- 7 - Vent



The "**GEISER INERTIA AND MASTER INERTIA**" series of tanks are thermally insulated at the factory by direct mould-injection with CFC-free and HCFC-free PU material. This system guarantees a perfectly regular insulation thickness with optimum material density. The thicknesses indicated in the table refer to the circular tank body, but the insulation is much thicker on the top part (up to four times greater). Because the top zone of the tank has better thermal protection, heat losses are much lower than those specified by the most stringent regulations, such as the DIN 4753/8 standard.



Rigid, mould-injected PU insulating material.



- *Minimal heat loss!*
- *For hot and cold water!*
- *No condensation on tank body!*
- *Compact block, no joints!*

TABLE OF THERMAL INSULATION: GEISER INERTIA / MASTER INERTIA SERIES

Serie	Tank model	Thermal insulation k= 0,025 W/m °K	Insulation thickness PU (mm.)	Static heat losses EN 12897 (W)	ErP  (EU 812/2013)	Minimum thickness of equivalent insulation with other insulating materials(mm)		
						Flexible polyurethane foam* k= 0,040 W/m °K	Rockwool* k= 0,034 - 0,042 W/m °K	Fiberglass* k= 0,035 - 0,046 W/m °K
GEISER INERTIA	G-50-IF	PU	40	37	B	65	55 - 70	55 - 75
GEISER INERTIA	G-80-IF and GX4-80-IF	PU	40	45	B	65	55 - 70	55 - 75
GEISER INERTIA	G-140-IF and GX4-140-IF	PU	40	60	C	65	55 - 70	55 - 75
GEISER INERTIA	G-200-IF and GX4200-IF	PU	40	60	B	65	55 - 70	55 - 75
GEISER INERTIA	G-260-IF/IF/IFS and GX4-260-IF	PU	40	83	C	65	55 - 70	55 - 75
GEISER INERTIA	G-370-IF/IF/IFS and GX4-370-IF	PU	40	85	C	65	55 - 70	55 - 75
GEISER INERTIA	GX4-500-IF	PU	60	81	B	65	55 - 70	55 - 75
GEISER INERTIA	G-600-IF/IF/IFS	PU	40	95	C	65	55 - 70	55 - 75
GEISER INERTIA	G-800-IF/IF/IFS/L*/LW*	PU	80	99/*87	C/*B	130	110 - 140	115 - 160
GEISER INERTIA	GX4-800-IF	PU	80	99	C	130	110 - 140	115 - 160
GEISER INERTIA	G-1000-IF/IF/IFS/L/LW	PU	80	114	C	130	110 - 140	115 - 160
GEISER INERTIA	GX4-1000-IF	PU	80	114	C	130	110 - 140	115 - 160
GEISER INERTIA	G-1500-IF/IF/IFS/L/LW	PU	80	156	C	130	110 - 140	115 - 160
MASTER INERTIA	MV-1500-IF/IF*/ISB*/L/LW	PU	80	145/*154	C	130	110 - 140	115 - 155
MASTER INERTIA	MV-2000-IF/IF*/ISB*/L/LW	PU	80	164/*174	C	130	110 - 140	115 - 155
MASTER INERTIA	MV-2500-IF/IF*/ISB*/L/LW	PU	80	183/*194	C	130	110 - 140	115 - 155
MASTER INERTIA	MV-3000-IF/IF*/ISB*/L/LW	PU	80	203/*215	C	130	110 - 140	115 - 155
MASTER INERTIA	MV-3500-IF/IF*/ISB*/L/LW	PU	80	218/*232	C	130	110 - 140	115 - 155
MASTER INERTIA	MV-4000-IF/IF*/ISB*/L/LW	PU	80	231/*245	C	130	110 - 140	115 - 155
MASTER INERTIA	MV-5000-IF/IF*/ISB*/L/LW	PU	80	250/*265	C	130	110 - 140	115 - 155
MASTER INERTIA	MV-6000-IF	PU	80	250/*280	C	130	110 - 140	115 - 155

(*) Detachable insulation systems can lose up to 25% of the insulating capacity overall, so that in that case the insulation thickness will increased proportionally.



THREADED IMMERSION HEATING ELEMENTS FOR PRIMARY HEATING CIRCUIT

Threaded immersion heating elements for primary heating circuit					
Reference	Electric element model	KW	V	Length L*	Optional application to tank models
G003806	RI 4/2-22	2,2	3-230 / 3-400	260	G-80-...-1500-IF/IFS
G003807	RI 4/2-54	5,4	3-230 / 3-400	345	G-80-...-1500-IF/IFS
G003808	RI 4/2-72	7,2	3-230 / 3-400	445	G-200-...-1500-IF/IFS
G003809	RI 4/2-90	9,0	3-230 / 3-400	505	G-200-...-1500-IF/IFS
G003810	RI 4/2-120	12,0	3-230 / 3-400	680	G-600-...-1500-IF/IFS



Threaded immersion heating elements for primary heating circuit.

GEISER INERTIA EXTERNAL LININGS

External linings for "GEISER INERTIA" tanks. Padded PVC lining with zip fastener, B2 class according to DIN 4102-1. Standard external lining: BLUE / RAL 5015. Rest of colours OPTIONAL, according to availability and the quantities of product ordered.



BLUE: RAL 5015



WHITE: RAL 9016



GREY: RAL 7045

MASTER INERTIA EXTERNAL LININGS

External lining for "MASTER INERTIA" tanks with top cover, ND400 side manhole cover and trims for hydraulic connections. Standard external lining: GREY / RAL 7042. (OPTIONAL: linning for outdoor).



Capacity (l)	Standard category (ref KIT)	Class M0 (KIT reference)	Weatherproof (KIT reference)
800	FME800	FME800/M0	FME800/EX
1000	FME1000	FME1000/M0	FME1000/EX
1500	FME1500	FME1500/M0	FME1500/EX
2000	FME2000	FME2000/M0	FME2000/EX
2500	FME2500	FME2500/M0	FME2500/EX
3000	FME3000	FME3000/M0	FME3000/EX
3500	FME3500	FME3500/M0	FME3500/EX
4000	FME4000	FME4000/M0	FME4000/EX
5000	FME5000	FME5000/M0	FME5000/EX
6000	FME6000	FME6000/M0	FME6000/EX

ALUNOX EXTERNAL LINING

External aluminium sheet lining. ALUNOX external lining is supplied ready-mounted on the tank, over the PU insulation.

Capacity (l)	ALUNOX EXTERNAL LINING WITHOUT MANHOLE	ALUNOX EXTERNAL LINING WITH MANHOLE
800	FME800/ALUNOX	FME800/ALUNOX-B
1000	FME1000/ALUNOX	FME1000/ALUNOX-B
1500	FME1500/ALUNOX	FME1500/ALUNOX-B
2000	FME2000/ALUNOX	FME2000/ALUNOX-B
2500	FME2500/ALUNOX	FME2500/ALUNOX-B
3000	FME3000/ALUNOX	FME3000/ALUNOX-B
3500	FME3500/ALUNOX	FME3500/ALUNOX-B
4000	FME4000/ALUNOX	FME4000/ALUNOX-B
5000	FME5000/ALUNOX	FME5000/ALUNOX-B





INDUSTRIAL CAPACITY DHW STORAGE TANKS 7000 to 12000 litres

lapesa has a range of DHW storage tanks with capacities of more than 7000 litres for special installations and industrial applications, made in STAINLESS STEEL or COATED STEEL.

lapesa has a range of DHW storage tanks with capacities of **more than 7000 litres** for special installations and industrial applications. DHW storage and production tanks made in **STAINLESS STEEL** or **COATED STEEL**.

This range of tanks can be fitted with our system of detachable stainless steel coils, adapting the heat exchange area to the installation's thermal power.

They are also designed to incorporate electric heating elements, both for back-up heating and as main heating. Our "dry" electric heating system with ceramic heating elements can be integrated in the ND400 side manhole, allowing the heating elements to be replaced without having to drain the storage tank.

The main options available for these storage tanks are "**lapesa correx-up**" permanent cathodic protection units or detachable insulation in 50 or 100 mm-thick glassfibre with PVC external lining (separate supply).

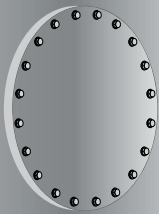

EQUIPMENT

WITH COILS:

MXV and **MV** models can be fitted with one or two sets of **lapesa** detachable stainless steel coils, up to 10 m² of exchange area per set, adapting to the thermal power of the external source and the requirements of the installation.



EQUIPMENT

WITH ELECTRIC HEATING ELEMENTS:

The ND400 side manhole can be fitted with low charge density Incoloy electric heating elements to achieve a maximum power of 200 Kw. The equipment option with our "dry" system with ceramic heating elements allows to achieve a maximum power of 48 Kw. As a special manufacturing option, this range of storage tanks can include a second ND400 side manhole to obtain up to 400 Kw with immersion heating elements and 96 Kw electric power with ceramic heating elements.



APPLICATIONS

**INDUSTRIAL CAPACITY STORAGE TANKS
7000 to 12000 litres**

- Industrial applications
- Food industry
- Textile industry
- Large storage volume facilities
- Centralized DHW facilities
- Energy management centres
- Specific projects



DHW TANKS: STAINLESS STEEL

- Capacity: **7000 to 12000 litres.**
- Material: **AISI 304 L or AISI 316 L stainless steel.**
- Working pressure: **8 bar** (optional: 10, 12 bar).
- Maximum working temperature: **90°C.**
- **ND400** side manhole.
- Internal surface treatment: chemical pickling and passivation.
- Installation: vertical (horizontal as an option).
- OPTIONAL: **lapesa** detachable coils system for DHW production.
- OPTIONAL: "lapesa correx-up" permanent cathodic protection unit.
- OPTIONAL: immersion or ceramic electric heating elements.
- OPTIONAL: thermal insulation, flexible PVC external lining with 50 or 100 mm thick glass fibre, supplied separately.

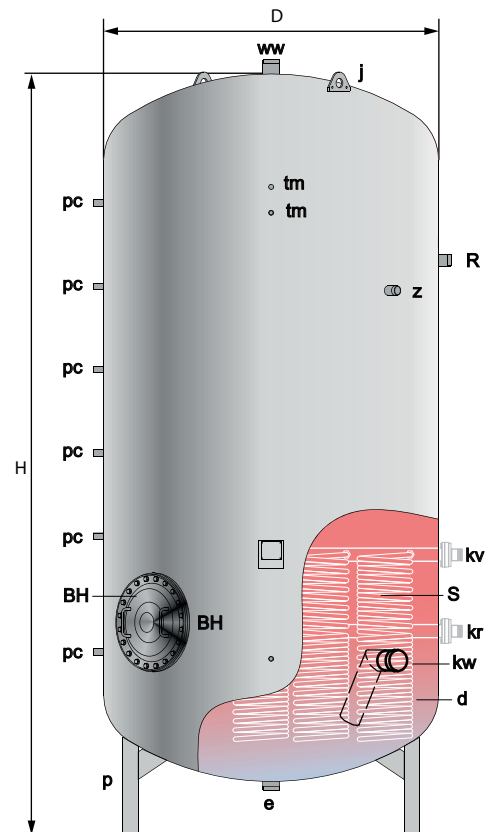

BH - Manhole ND400
 d - DHW tank
 j - Lifting lugs
 p - Support legs
 S - Heating coils (OPTIONAL)

GENERAL CHARACTERISTICS		MXV-7000-RB	MXV-8000-RB	MXV-10000-RB	MXV-12000-RB
DHW capacity	l.	7000	8000	10000	12000
D: external diameter	mm.	1750	1750	1750	1750
H: overall height	mm.	3633	4058	4808	5808
kw: cold water inlet / drain	" GAS/M	3	3	3	3
ww: DHW outlet	" GAS/M	3	3	3	3
z: recirculation	" GAS/M	1 1/2	1 1/2	1 1/2	1 1/2
R: side connection	" GAS/F	2	2	2	2
pc: "lapesa correx up" connection	" GAS/M	3/4	3/4	3/4	3/4
tm: probe tube connection for sensors	" GAS/F	1/2	1/2	1/2	1/2
Empty weight (approx.)	Kg	677	757	887	1059
Side manhole	ND	ND400	ND400	ND400	ND400
COILS OPTION (heat exchange surface 10 M ²)		MXV-7000-SB	MXV-8000-SB	MXV-10000-SB	MXV-12000-SB
kv: primary input	" GAS/M	2	2	2	2
kr: primary return	" GAS/M	2	2	2	2
Empty weight (approx.)	Kg	760	860	990	1162

DHW TANKS: **COATED STEEL**

- Capacity: **7000 to 12000 litres.**
- Material: **S275JR carbon steel.**
- Interior treatment: SA 2 ½ interior shotblasting with 400 micra food grade **epoxy coating.**
- Working pressure: **8 bar** (optional: 10, 12 bar).
- Maximum working temperature: **75°C.**
- **ND400** side manhole.
- External treatment: rust prevention primer.
- Installation: vertical (horizontal as an option).
- OPTIONAL: Lapesa detachable coils system for DHW production.
- OPTIONAL: "lapesa correx-up" permanent cathodic protection.
- OPTIONAL: immersion or ceramic electric heating elements.
- OPTIONAL: thermal insulation, flexible PVC external lining with 50 or 100 mm thick glass fibre, supplied separately.

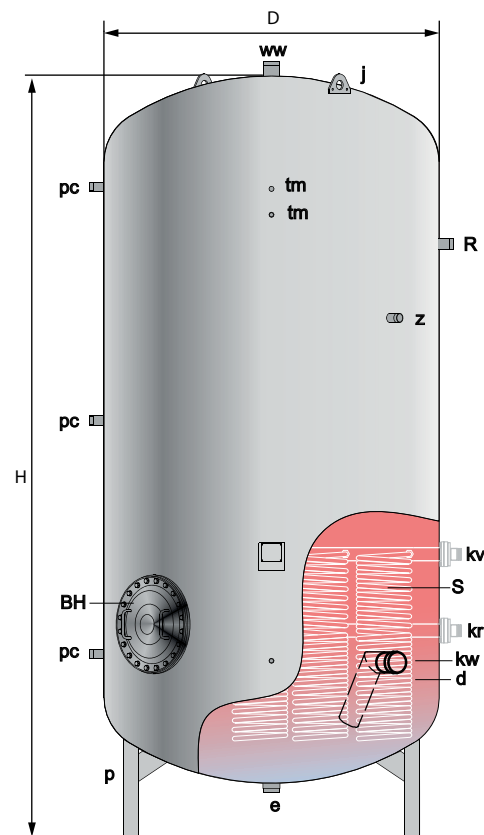

BH - Manhole ND400
 d - DHW tank
 j - Lifting lugs
 p - Support legs
 S - Heating coils (OPTIONAL)

GENERAL CHARACTERISTICS		MV-7000-RB	MV-8000-RB	MV-10000-RB	MV-12000-RB
DHW capacity	l.	7000	8000	10000	12000
D: external diameter	mm.	1750	1750	1750	1750
H: overall height	mm.	3633	4058	4808	5808
kw: cold water inlet / drain	" GAS/M	3	3	3	3
ww: DHW outlet	" GAS/M	3	3	3	3
z: recirculation	" GAS/M	2	2	2	2
e: drain	" GAS/M	2	2	2	2
R: side connection	" GAS/F	2	2	2	2
pc: "lapesa correx up" connection	" GAS/M	1 1/2	1 1/2	1 1/2	1 1/2
tm: probe tube connection for sensors	" GAS/F	3/4	3/4	3/4	3/4
Empty weight (approx.)	Kg	1010	1057	1205	1437
Side manhole	ND	ND400	ND400	ND400	ND400
COILS OPTION (heat exchange surface 10 M ²)		MV-7000-SB	MV-8000-SB	MV-10000-SB	MV-12000-SB
kv: primary input	" GAS/M	2	2	2	2
kr: primary return	" GAS/M	2	2	2	2
Empty weight (approx.)	Kg	1113	1160	1308	1540

TANKS: INERTIA

- Capacity: **7000 to 12000 litres.**
- Material: **S275JR carbon steel.**
- Working pressure: **6 bar.**
- Maximum working temperature: **110°C.**
- **ND400** side manhole.
- Internal treatment: free of particles.
- External treatment: rust prevention primer.
- Installation: vertical (horizontal as an option).
- OPTIONAL: electric heating elements.
- OPTIONAL: thermal insulation, flexible PVC external lining with 50 or 100 mm thick glass fibre, supplied separately.

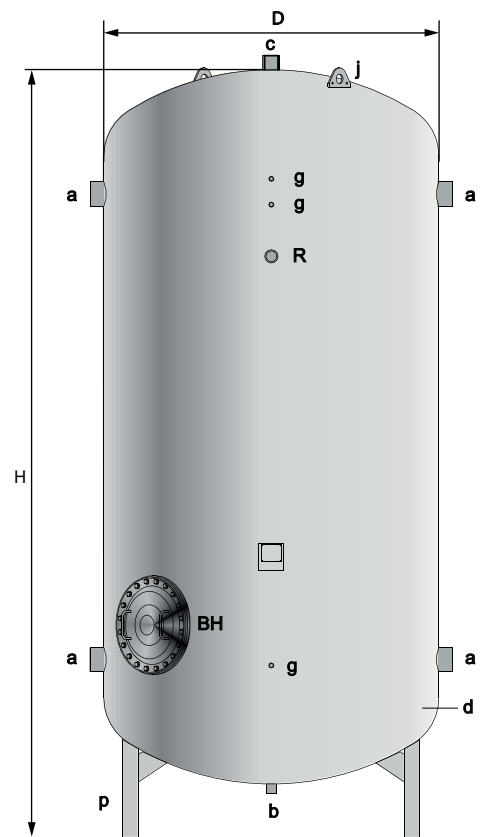

BH - Manhole ND400
 d - DHW tank
 j - Lifting lugs
 p - Support legs

GENERAL CHARACTERISTICS		MV-7000-IB	MV-8000-IB	MV-10000-IB	MV-12000-IB
Capacity	l.	7000	8000	10000	12000
D: external diameter	mm.	1750	1750	1750	1750
H: overall height	mm.	3652	4090	5013	5835
a: side connection	" GAS/F	4	4	4	4
b: lower connection	" GAS/F	1 1/4	1 1/4	1 1/4	1 1/4
c: upper connection	" GAS/F	2	2	2	2
R: side connection	" GAS/F	2	2	2	2
g: conexión sensores	" GAS/F	3/4	3/4	3/4	3/4
Side manhole	ND	ND400	ND400	ND400	ND400
Empty weight (approx.)	Kg	1005	1044	1243	1420

INDUSTRIAL CAPACITY STORAGE TANKS





HYDROMASTER from 40 to 1000 kW

Equipment for semi-instantaneous production of DHW

DHW PRODUCTION CAPACITY:

Wide range of equipment for semi-instantaneous production of DHW, power ratings from **40 to 1000 kW**.

COMFORT:

Immediate availability of DHW, in combination with storage tanks **"RB"**.

LONG USEFUL LIFE:

High performance plate heat exchanger in **stainless steel AISI-316**.

ANTI-LEGIONELLA FUNCTION:

Integrated programming for the periodical anti-legionella treatment via thermal shock.

REDUCED SPACE:

Ideal for installations in reduced space, with high requirements for DHW production.

EXAMPLE OF HYDRAULIC SCHEME

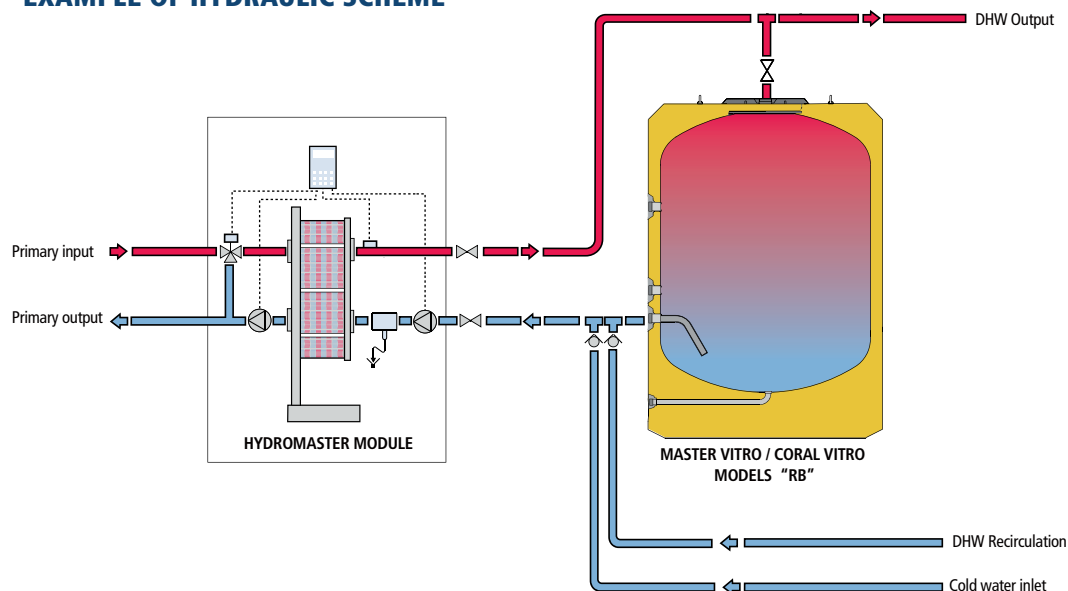

HYDROMASTER

COMPONENTS:

- 1- **Plate heat exchanger** AISI-316L with heat insulation
- 2- **Circulation pump for primary circuit** high performance type (class A) with variable speed
- 3- **Circulation pump for secondary circuit** high performance type (class A) with variable speed
- 4- **Three way valve** with servomotor in primary circuit
- 5- **Multifunction screen** for programming and data display. Electric box IP55, 240V 50Hz monophasic
- 6- **Frame made** of steel with RAL 5010 blue finishing
- 7- **Safety valve** 7 bar with thermometer in secondary circuit
- 8- **Probe** DHW
- 9- **Purge**
- 10- **Drain**

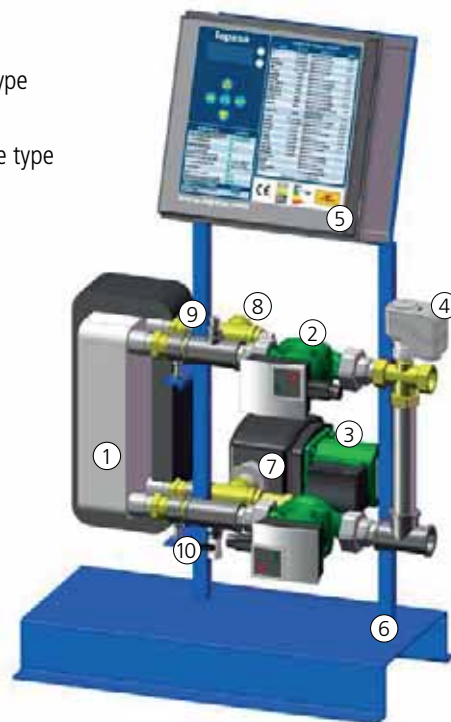

FEATURES:

- **Anti-legionella** programming via thermal shock
- **ECO mode** for automatic stop of primary circuit pumps
- **BOOST mode** for prompt power increase in DS model

OPTIONAL:

- Models ECO including heat exchanger with detachable plates
- Expanded control unit with MODBUS, LON and BACNET connections
- Power rating up to 1000kW available
- Other primary temperatures, please consult

HYDROMASTER MODELS SS - DS - DD

Primary 80/45°C Secondary 55/10°C	Power (kW)	Plate heat exchanger	Length (mm)	Width (mm)	Height (mm)
HMSI40SS80 ECO	40	Compact	588	490	985
HMSI70SS80 ECO	70	Compact	588	490	985
HMSI110SS80 ECO	110	Compact	588	490	985
HMSI170SS80 ECO	170	Compact	588	490	985
HMSI240SS80	240	Detachable	700	525	1030
HMSI310SS80	310	Detachable	700	525	1030
HMSI400SS80	400	Detachable	700	525	1030
HMSI470SS80	470	Detachable	700	525	1030

SS model: Single pump on primary side, single pump on secondary side. Semi-instantaneous DHW production
DS model: Double pump on primary side, single pump on secondary side. Semi-instantaneous DHW production
DD model: Double pump on primary side, double pump on secondary side. Semi-instantaneous DHW production
 Instantaneous DHW production: please consult

All offers and agreements shall be based exclusively on the following conditions; any other conditions by customers shall not be binding unless expressly agreed in writing.

GENERAL

Agreements shall only be binding if confirmed in writing by Lapesa.

The customer shall be responsible for the accuracy of the documentation that he provides, especially that of samples and drawings. Data, drawings, representations and descriptions of performances that appear in our catalogues, price lists or documentation pertaining to the offer, give approximate values usual within the sector unless it is specifically indicated in the order confirmation that they are binding. Conditions specified by buyers in orders that are not in accordance with our general sales conditions or, if relevant with the special conditions for each product shall be deemed invalid unless they have been agreed to by us and express mention is made of them in the written order acceptance. Orders that have been accepted may not be cancelled by customers if said orders are special productions and the materials required to produce them have been acquired; nor may they be cancelled after 5 working days from our acceptance of the order or if the materials have been dispatched.

DELIVERY TIMES AND DELIVERY TERMS

Delivery times are considered to be approximate unless a firm date of delivery has been indicated. The delivery time shall be counted from the date on which the order confirmation is sent or the date on which the deposit payment, if required, is received and shall be considered to have been fulfilled when the merchandise leaves our factory or warehouse on the date agreed or when its availability for dispatch to the customer has been notified. In the event that the contract were to be subsequently modified by the customer in such a way that this were to affect the delivery date, it may be prolonged in a reasonably correlative way.

In the case of supplies for which prior notification must be given, these must be collected or their delivery authorised within a period of 15 days from our notification to the customer indicating that the material is available, otherwise the material will be incorporated into Lapesa's stocks and may be used as required by Lapesa. Lapesa shall inform customers of the conditions and the period in which the merchandise can be supplied.

Delays in delivery due to force majeure or deriving from extraordinary or unforeseen causes that cannot be avoided by Lapesa will not give rise to any type of penalty nor the cancellation by the customer of the order that has involuntarily been delayed.

The buyer may not reject partial supplies.

Delivery is carried out ex Lapesa works or ex Lapesa warehouse provided that no other agreement has been made and without any commitment regarding the most economical way of carrying out the delivery. Unloading operations are for the customer's account unless otherwise agreed.

In the event of supplies that are sent carriage forward the risks are transferred to the customer at the time that the merchandise is handed over to the person responsible for transporting it.

PRICE

The prices that are shown in our price list are ex-works or ex-warehouse, plus the corresponding value added tax in force at the time, delivery and packaging costs, if a different type of packaging to that usually provided is required.

The prices in the price tariffs may be modified by Lapesa at any time. Said modification shall affect all those orders pending delivery at the date of the modification. If the customer were not to accept the new price he shall be entitled to cancel the order within the 10 days following the notification of the price increase. Any discount that is agreed presupposes on-time fulfilment of all obligations to us, including those deriving from other contracts.

PAYMENT TERMS

All invoices shall be paid at sight, upon delivery of the merchandise, unless the buyer has been allowed credit, in which case they shall be paid in the periods expressly indicated.

If a buyer is allowed credit payment shall be carried out by accepted domiciled letter of exchange, except in the case of special agreements.

If the date of payment is exceeded Lapesa shall add the corresponding interests to the unpaid amount as well as the com arising from non-payment or the bill return.

The first sales operations with a customer will always be at sight terms.

If after signing a contract, Lapesa were to come to know facts that imply a substantial worsening in the financial conditions of the customer and which could endanger its right to good consideration, Lapesa may suspend delivery of the goods unless the customer pays first.

GUARANTEE

Our products are guaranteed against all manufacturing defects for the period, and according to the conditions, expressly indicated for each product in its corresponding catalogue or guarantee, provided that they are used and installed in normal conditions, in accordance with the regulations in force or the specific installation and usage instructions issued by Lapesa.

Our guarantee only covers manufacturing defects, never operating or installation defects and thus replacement of material free of charge for the buyer will be carried out within the terms established in current legislation and the terms specified in the product guarantee.

OWNERSHIP

Lapesa reserves the right of ownership of the merchandise supplied up to the time that all of the obligations deriving from the commercial relationship have been fulfilled, including the obligations that may arise in the future from the same contract or from other contracts signed with the customer.

RETURNS

No returns are allowed without our prior consent.

If a return is authorised the merchandise shall be sent by the customer carriage paid to the factory or warehouse specified by Lapesa.

All costs of reception of materials, inspection and testing and repair if relevant shall be discounted from the amount to be paid into the customer's account, deducting an amount of no less than 10%.

CUSTOMER SERVICE

All claims and communications indicating the intention to return merchandise, other than those covered by the guarantee, must be notified to Lapesa's customer service department within 10 days from the date of delivery of the materials. Once Lapesa has decided on the admissibility or inadmissibility of such claims, it will proceed accordingly.

JURISDICTION

The place in which the contracting parties shall comply with their obligations will be Zaragoza.

The competent jurisdiction for all types of discrepancies arising from the contract or concerning its validity provided that this is licit shall be the local courts or tribunals of Zaragoza.

The law in force at the site of our registered offices shall be applicable.



MARKETS

EUROPA

ANDORRA
 GERMANY
 ARMENIA
 AUSTRIA
 BELGIUM
 BULGARIA
 FINLAND
 FRANCE
 HOLLAND
 IRELAND
 ITALY
 NORWAY
 POLAND
 PORTUGAL
 UNITED KINGDOM
 RUSSIA
 SLOVENIA
 SPAIN
 SWITZERLAND

AMERICA

ARGENTINA
 BOLIVIA
 CHILE
 COLOMBIA
 CUBA
 DOMINICAN REP.
 GUADALUPE ISLAND
 MEXICO
 PERU

AFRICA

ALGERIA
 ANGOLA
 BENIN
 CAMEROON
 CHAD
 IVORY COAST
 GABON
 REUNION ISLAND
 KENYA
 MADAGASCAR
 MOROCCO
 MAURITANIA
 NAMIBIA
 NIGER
 NIGERIA
 SOUTHAFRICA
 TANZANIA
 TUNISIA

MIDDLE EAST

EMIRATES
 JORDANIA
 KUWAIT
 LEBANON
 OMAN
 QATAR
 SAUDI ARABIA

ASIA

BANGLADESH
 MONGOLIA
 SRI LANKA
 VIETNAM

OCEANIA

AUSTRALIA
 NEW ZELAND

SOUTH POLE

ANTARCTICA



HEAD OFFICE Lapesa Grupo Empresarial
 Pol. Ind. Malpica - Calle A, Parcela 1-A 50016 ZARAGOZA (España)
 Tel.: 976 465 180 / Fax: 976 574 393
 e-mail: lapesa@lapesa.es * www.lapesa.com

ICON LEGEND:



HEAT PUMP



SOLAR COLLECTORS



GAS/OIL-FIRED BOILER



SOLID FUEL BOILER



ELECTRIC HEATING ELEMENTS



SEVERAL COMBINED ENERGY SOURCES



REGULATION AND CONTROL



THERMAL INSULATION



CATHODIC PROTECTION



ACCESSORIES

DHW **lapesa**
Solutions



lapesa

Lapesa Grupo Empresarial

Pol. Ind. Malpica - Calle A, Parcela 1-A
50016 ZARAGOZA (SPAIN)

Tel.: +34 976 465 180 / Fax: +34 976 574 393

e-mail: lapesa@lapesa.es * www.lapesa.com



ISO 9001
BUREAU VERITAS
Certification

