

Data sheet – Spare parts and accessories

Float valve  
Type HFI

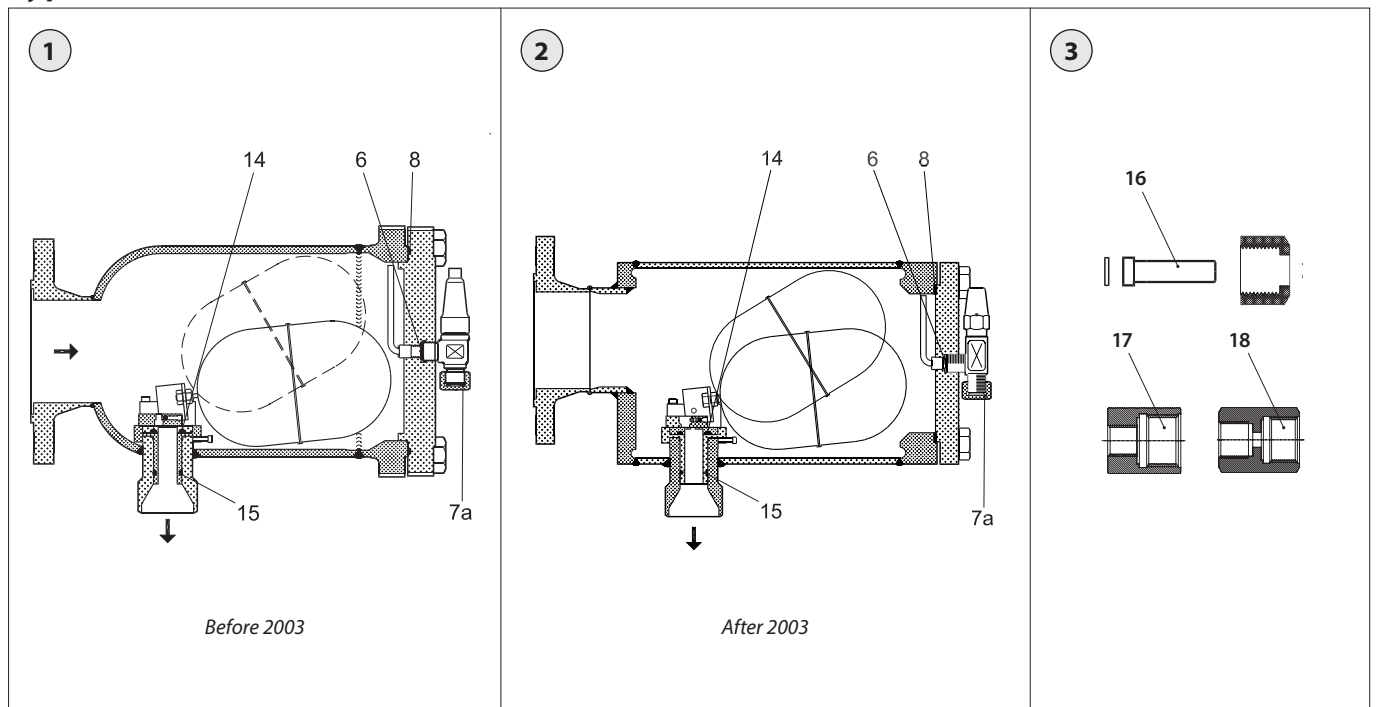

Description	Type of nozzle (nominal capacity)	Pos. #	Qty.	Code no.
<b>Repair kit, complete set of gaskets</b>				
Gasket	040	6	1	<b>2453+094</b>
Gasket		7a	1	
O-ring for housing/end cover (Before 2003)		8	1	
Gasket for housing/end cover (After 2003)		8	1	
O-ring		14	1	
O-ring		15	1	
<b>Repair kit, complete set of gaskets</b>				
Gasket	050	6	1	<b>2453+094</b>
Gasket		7a	1	
O-ring for housing/end cover (Before 2003)		8	1	
Gasket for housing/end cover (After 2003)		8	1	
O-ring		14	1	
O-ring		15	1	
<b>Repair kit, complete set of gaskets</b>				
Gasket	060	6	1	<b>2453+094</b>
Gasket		7a	1	
O-ring for housing/end cover (Before 2003)		8	1	
Gasket for housing/end cover (After 2003)		8	1	
O-ring		14	1	
O-ring		15	1	
<b>Repair kit, complete set of gaskets</b>				
Gasket	070	6	1	<b>2453+094</b>
Gasket		7a	1	
O-ring for housing/end cover (Before 2003)		8	1	
Gasket for housing/end cover (After 2003)		8	1	
O-ring		14	1	
O-ring		15	1	

Description	Type of nozzle (nominal capacity)	Pos. #	Qty.	Code no.
<b>Complete renewal kit*</b>				
Gasket	040	6	1	<b>148G3661</b>
Gasket		7a	1	
O-ring for housing/end cover (Before 2003)		8	1	
Gasket for housing/end cover (After 2003)		8	1	
Complete insert including the float ball (R717)		-	1	
		-	-	
Gasket	050	6	1	<b>148G3662</b>
Gasket		7a	1	
O-ring for housing/end cover (Before 2003)		8	1	
Gasket for housing/end cover (After 2003)		8	1	
Complete insert including the float ball (R717)		-	1	
		-	-	
Gasket	060	6	1	<b>148G3663</b>
Gasket		7a	1	
O-ring for housing/end cover (Before 2003)		8	1	
Gasket for housing/end cover (After 2003)		8	1	
Complete insert including the float ball (R717)		-	1	
		-	-	
Gasket	070	6	1	<b>148G3584</b>
Gasket		7a	1	
O-ring for housing/end cover (Before 2003)		8	1	
Gasket for housing/end cover (After 2003)		8	1	
Complete insert including the float ball (R717)		-	1	
		-	-	
<b>Welding nipple - G½-ND6</b>				
Welding nipple including aluminium gasket	-	16	2	<b>148B4184</b>
Aluminium gaskets included - ¼" FPT - ½" G	-	17	1	<b>148B3860</b>
Aluminium gaskets included - ¾" G - ½" G	-	18	1	<b>148B3861</b>

\* The float mechanism is assembled and adjusted from factory

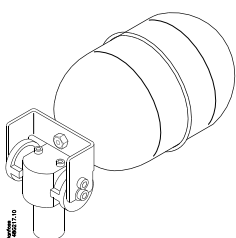

HFI insert after 2006