



Product: FrameFoot MINI

Code: FF-755

Group:  FrameFoot™

Supporting system for heat pumps and condensers

Application:

All in one box anti-vibration support frame for heat pumps, condensers and VRF/VRV units installed on the ground or flat roofs with an adjustable slope of maximum 5%.

Description:

- For outdoor units with max dimensions: 755 x 520 mm (width x depth)
- Height adjustment from 330 up to 370 mm with M12 screw



- Horizontal bracket allows easy width regulation from 450 up to 755 mm
- Recycled Rubber feet and pads are strong very effectively reduces the noise caused by vibrations
- Max load capacity. 360 kg
- Anti-corrosion protection of the frame and INOX fasteners ensure long-lasting protection and aesthetics

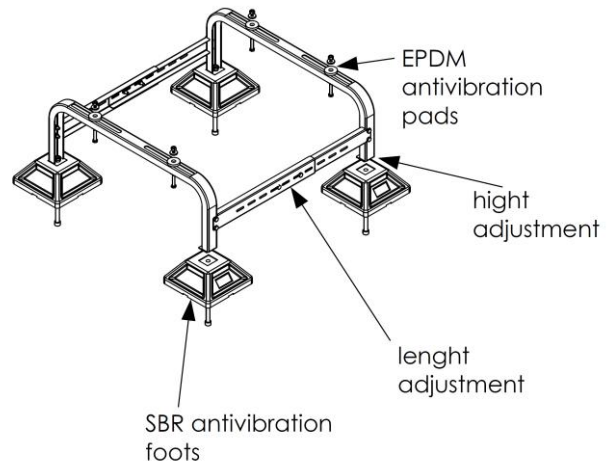

The frame

- Galavanised and powder coated steel , colored in RAL7021.Other colors on request
- Manufactured according the standard :
EN 1993-4-2:2009, EN 10025
- Only INOX fasteners

The foot

- SBR Recycled feet with steel insert
- Size 200x200 mm
- UV resistant
- Color: black
- Working temperature: - 40°C - 100°C
- Load capacity: 150 kg /foot

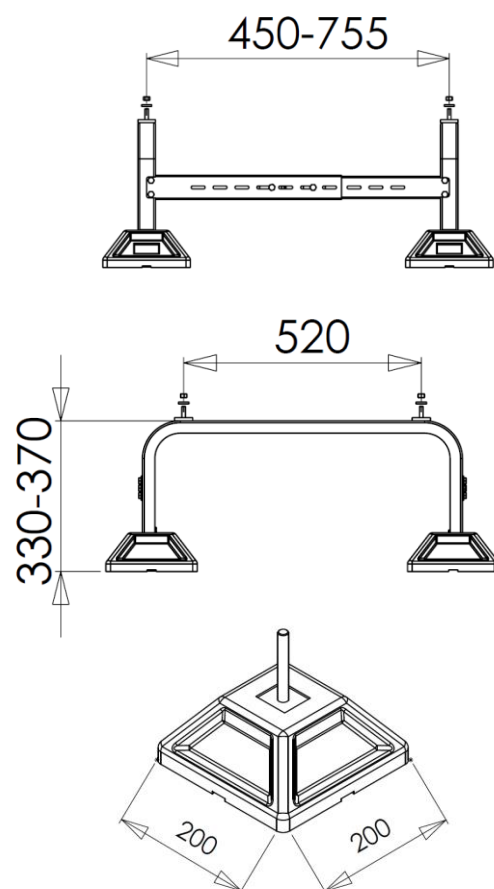

Dimensions:

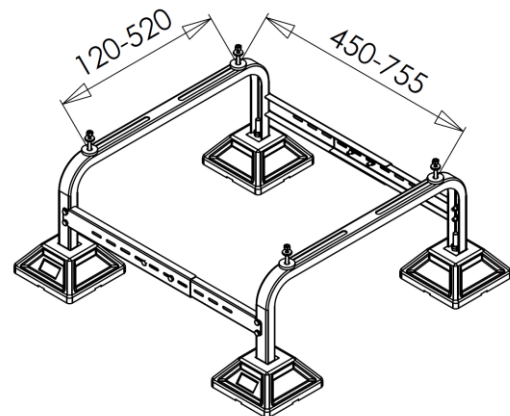
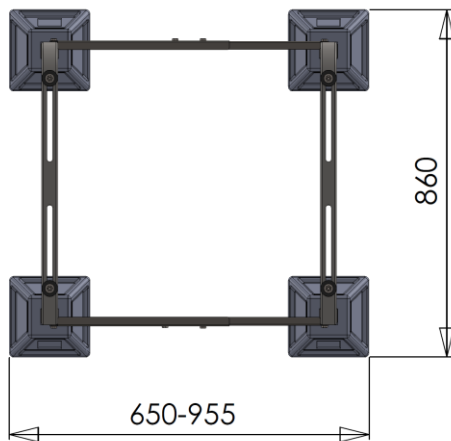
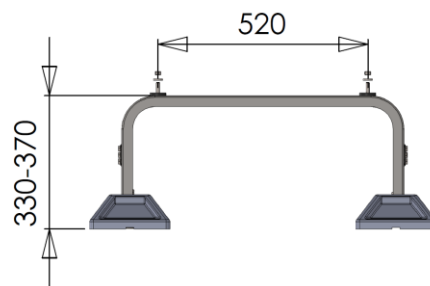
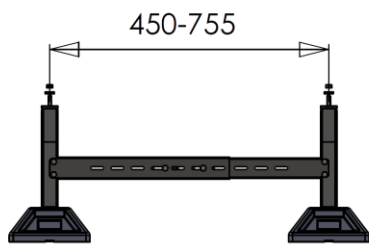

Allows installation on the sloped surface up to 5%:

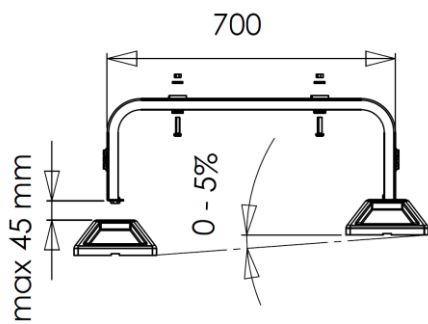

See also:

Rubberblocks



Frame Foot



Important:
