

Data Sheet

Solenoid valve Type **EVRA** and **EVRAT**

Capable of accommodating the higher pressures of refrigerants and a broader range of applications

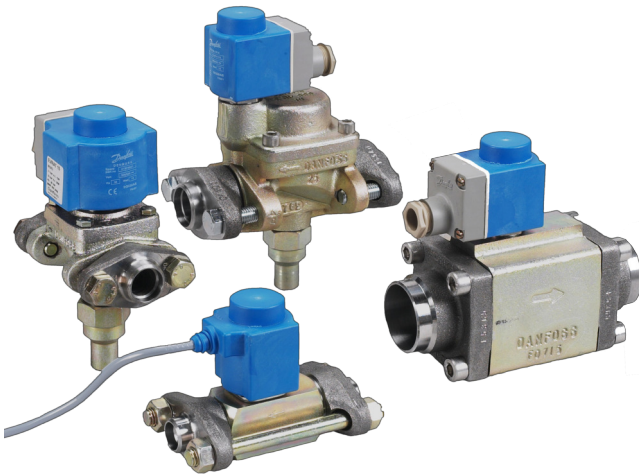

EVRA is a direct or servo operated solenoid valve for liquid, suction and hot gas lines with ammonia or fluorinated refrigerants.

EVRA valves are supplied complete or as separate components, i.e. valve body, coil and flanges can be ordered separately.

EVRAT is an assisted lift, servo operated solenoid valve for liquid, suction and hot gas lines with ammonia and fluorinated refrigerants.

EVRAT is specially designed to open - and stay open - at a pressure drop of 0 bar. The EVRAT solenoid valve is thus suitable for use in all plant where the required opening differential pressure is 0 bar.

EVRAT is available as components, i.e. valve body, flanges and coil must be ordered separately.

EVRAT 10, 15 and 20 all have spindle for manual operation.

Features:

- Refrigerants: Applicable to HCFC, HFC and R717 (Ammonia)
- Temperature of medium -40 °C – +105 °C and Max. 130 °C during defrosting
- Classification: DNV, CRN, BV, EAC etc. To get an updated list of certification on the products please contact your local Danfoss Sales Company

Functions

EVRA solenoid valves are designed on two different principles:

1. Direct operation
2. Servo operation

Table 1: Design Function - EVRA 3, EVRA 32 and EVRA 40

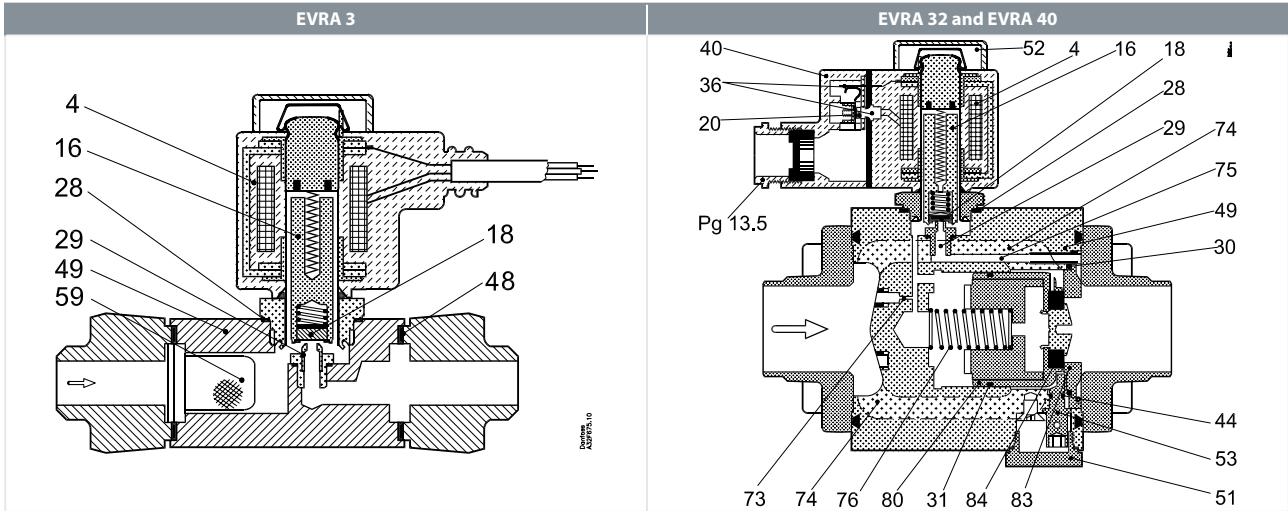
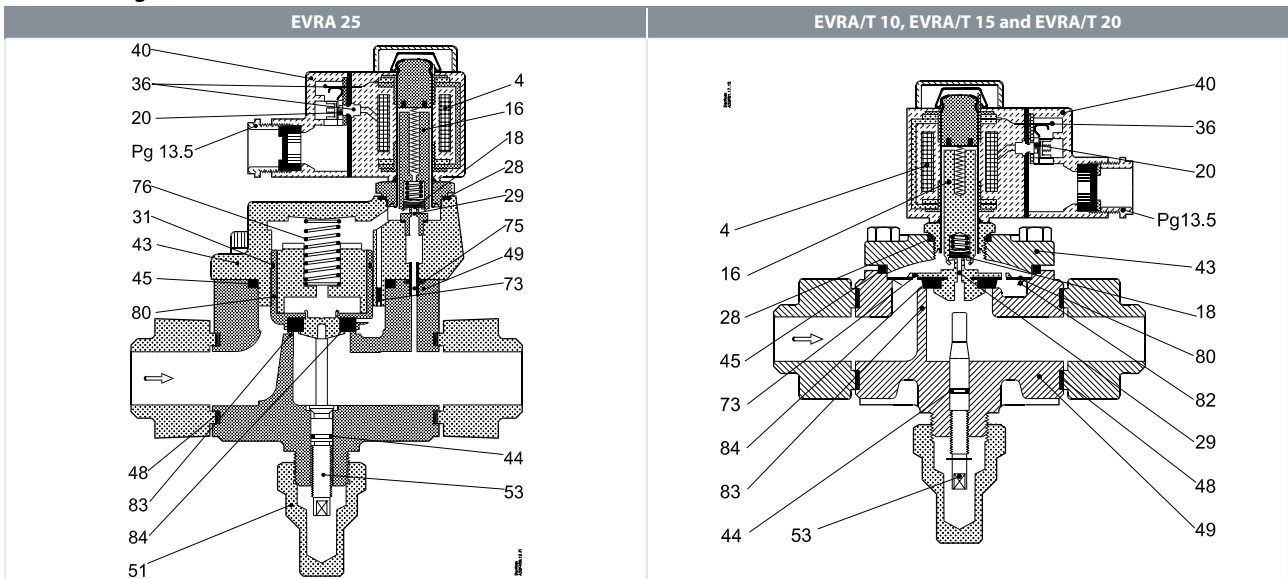

Table 2: Design Function - EVRA 25, EVRA/T 10, EVRA/T 15 and EVRA/T 20



4	Coil	36	DIN plug	59	Strainer
16	Armature	40	Terminal box	73	Equalization hole
18	Valve plate / Pilot valve plate	43	Valve cover	74	Main channel
20	Earth terminal	44	O-ring	75	Pilot channel
24	Connection for flexible steel hose	45	Valve cover gasket	76	Compression spring
28	Gasket	48	Flange gasket	80	Diaphragm/Servo piston
29	Pilot orifice	49	Valve body	82	Support washer
30	O-ring	51	Cover / Threaded plug	83	Valve seat
31	Piston ring	53	Manual operation spindle	84	Main valve plate

Direct operation

EVRA 3 is direct operated. The valve opens direct for full flow when the armature (16) moves up into the magnetic field of the coil. This means that the valve operates with a min. differential pressure of 0 bar. The teflon valve plate (18) is fitted direct on the armature (16).

Inlet pressure acts from above on the armature and the valve plate. Thus, inlet pressure, spring force and the weight of the armature act to close the valve when the coil is currentless.

Servo operation

EVRA/T 10 → 20 are servo operated with a “floating” diaphragm (80). The pilot orifice (29) of stainless steel is placed in the centre of the diaphragm. The teflon pilot valve plate (18) is fitted direct to the armature (16).

When the coil is currentless, the main orifice and pilot orifice are closed. The pilot orifice and main orifice are held closed by the weight of the armature, the armature spring force and the differential pressure between inlet and outlet sides.

When current is applied to the coil the armature is drawn up into the magnetic field and opens the pilot orifice. This relieves the pressure above the diaphragm, i.e. the space above the diaphragm becomes connected to the outlet side of the valve. The differential pressure between inlet and outlet sides then presses the diaphragm away from the main orifice and opens it for full flow. Therefore a certain minimum differential pressure is necessary to open the EVRA valve and keep it open. For differential pressure 0 bar use EVRAT valves. For EVRA 10 → 20 valves this differential pressure is 0.05 bar.

When current is switched off, the pilot orifice closes. Via the equalization holes (73) in the diaphragm, the pressure above the diaphragm then rises to the same value as the inlet pressure and the diaphragm closes the main orifice.

EVRA 25, 32 and 40 are servo operated piston valves. The valves are closed with currentless coil. The servo piston (80) with main valve plate (84) closes against the valve seat (83) by means of the differential pressure between inlet and outlet side of the valve, the force of the compression spring (76) and possibly the piston weight.

When current to the coil is switched on, the pilot orifice (29) opens. This relieves the pressure on the piston spring side of the valve. The differential pressure will then open the valve. The minimum differential pressure needed for full opening of the valves is 0.2 bar.

i NOTE:

The manual opener of EVRA/EVRAT 10, 15, 20 and 25 is intended to be activated only during initial pressure testing of the refrigeration system. After pressure testing or service-related manual forced opening of the manual opener the spindle must be turned fully back to back-seated position to avoid any packing gland leakage. Furthermore it is essential that the sealing cap is properly reinstalled. This will eliminate any risk of leakage from the manual opener.

Media

Refrigerants

Applicable to HCFC, HFC and R717 (Ammonia).

New refrigerants

Danfoss products are continually evaluated for use with new refrigerants depending on market requirements.

When a refrigerant is approved for use by Danfoss, it is added to the relevant portfolio, and the R number of the refrigerant (e.g. R513A) will be added to the technical data of the code number. Therefore, products for specific refrigerants are best checked at store.danfoss.com/en/, or by contacting your local Danfoss representative.

Product specification

Pressure and temperature data

Table 3: Pressure and temperature

Description	Values
Temperature of medium	-40 °C – +105 °C (Max. 130 °C during defrosting)

NOTE:

Ambient temperature and enclosure for coil - Refer Data sheet “Solenoid coil” (AI237186440089en-000801)

Table 4: Pressure and temperature

Type	Opening differential pressure with standard coil (Δp bar)				Temperature of medium ⁽¹⁾ [°C]	Max. working pressure PB [bar]	k_v -value ⁽²⁾ [m ³ /h]
	Min.	Max. (= MOPD) liquid ⁽³⁾					
		10 W AC	12 W AC	20 W DC			
EVRA 3	0	21	25	14	-40 – 105	42	0.23
EVRA 10	0.05	21	25	18	-40 – 105	42	1.5
EVRAT 10	0	14	21	16	-40 – 105	42	1.5
EVRA 15	0.05	21	25	18	-40 – 105	42	2.7
EVRAT 15	0	14	21	16	-40 – 105	42	2.7
EVRA 20 with AC coil	0.05	21	25	13	-40 – 105	42	4.5
EVRA 20 with DC coil	0.05	19	21	16	-40 – 105	42	4.5
EVRAT 20	0	14	21	13	-40 – 105	42	4.5
EVRA 25	0.2	21	25	14	-40 – 105	42	10
EVRA 32	0.2	21	25	14	-40 – 105	42	16
EVRA 40	0.20	21	25	14	-40 – 105	42	25

⁽¹⁾ Max. 130 °C during defrost

⁽²⁾ The k_v value is the water flow in m³/h at a pressure drop across valve of 1 bar, $\rho = 1000 \text{ kg/m}^3$

⁽³⁾ MOPD for media in gas form is approx. 1 bar greater

Material specification

Figure 1: EVRA 3 and EVRA/T 10/15/20

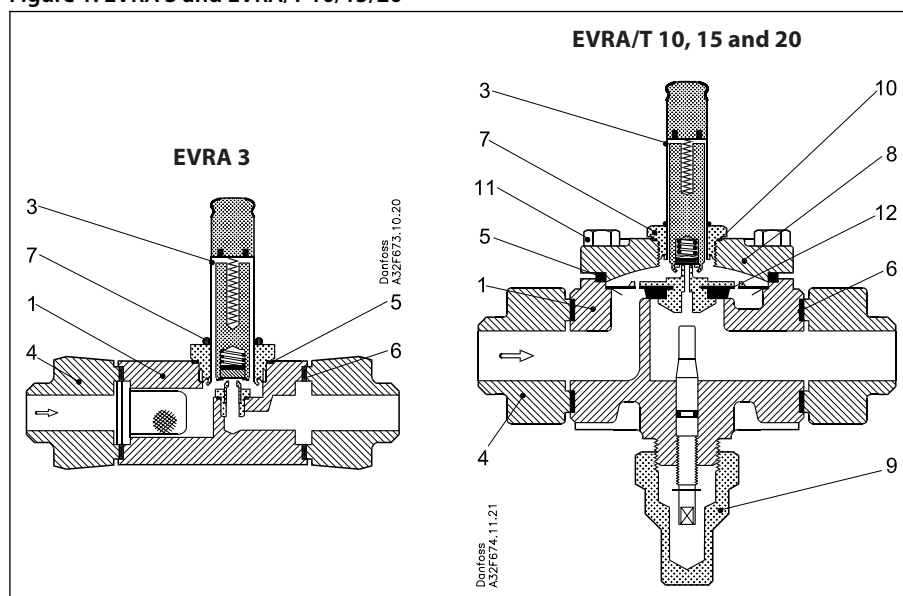

Table 5: EVRA 3 and EVRA/T 10/15/20

No.	Description	Solenoid valves	Material	Analysis	Mat.	W.nc	ISO	EN
1	Valve body	EVRA 3	Free-cutting steel	11MnPb30				10277-3
	Valve body	EVRA/T 10/15/20	Cast-iron	GJS-400-18-LT				1563
3	Armature tube	EVRA 3/10/15/20	Stainless steel	X2CrNi19-11				10088
4	Flange	EVRA/T 3/10/15/20	Steel	S235JRG2				10025

Solenoid valve, type EVRA and EVRAT

No.	Description	Solenoid valves	Material	Analysis	Mat.	W.nc	ISO	EN
5	Gasket	EVRA 3	Aluminium	Al 99.5				10210
	Gasket	EVRA/T 10/15/20	Rubber	Cr				
6	Gasket	EVRA/T 3/10/15/20	asbestos-free					
7	Armature tube nut	EVRA/T 3/10/15/20	Stainless steel	X8CrNiS18-9				10088
8	Cover	EVRA/T 10/15/20	Cast-iron	GJS-400-18-LT				1563
9	Cover/ thread plug	EVRA/T 10/15/20	Free-cutting steel	11SMnPb30				10277-3
10	Gasket	EVRA/T 10/15/20	Aluminium	Al 99.5				10210
11	Bolts	EVRA/T 10/15/20	Stainless steel	A2-70			3506	
12	Valve seat	EVRA/T 10/15/20	Teflon (PTFE)					

Figure 2: EVRA 25 and EVRA 32/40

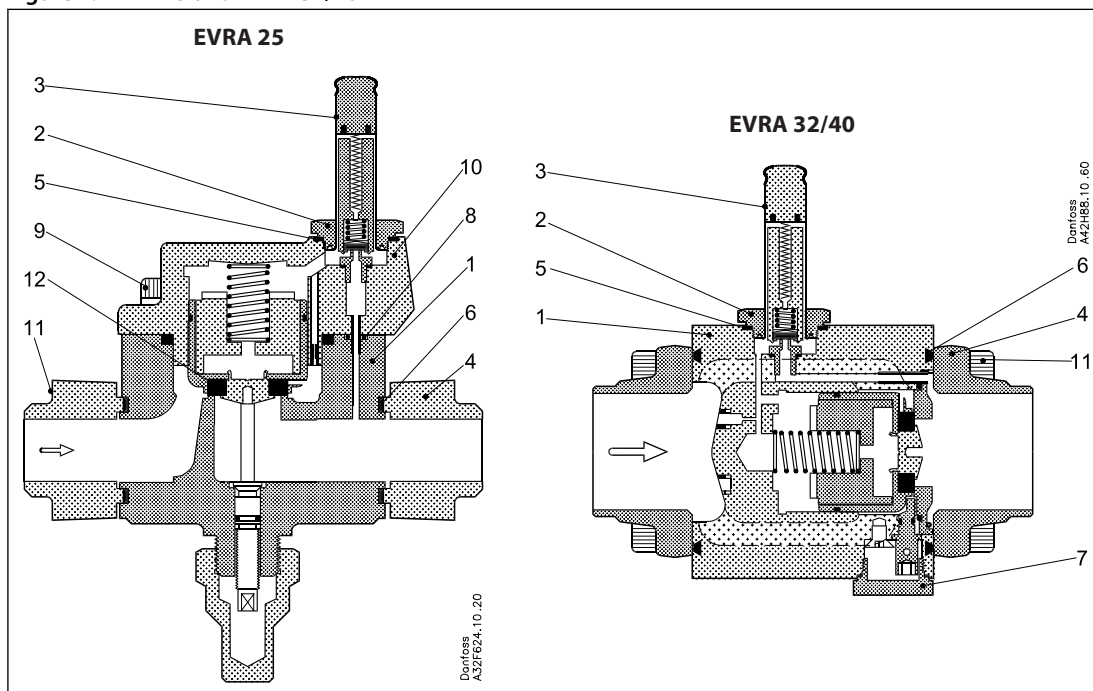

Table 6: EVRA 25 and EVRA 32/40

No.	Description	Solenoid valves	Material	Analysis	Mat.	W.nc	ISO	EN
1	Valve body	EVRA 25/32/40	Cast-iron	GJS-400-18-LT				1563
2	Armature tube nut	EVRA 25/32/40	Stainless steel	X8CrNiS 18-9				10088
3	Armature tube	EVRA 25/32/40	Stainless steel	X2CrNi19-11				10088
4	Flange	EVRA 25	Steel	S235JRG2				10025
	Flange	EVRA 32/40	Steel	P285QH				10222-4
5	Gasket	EVRA 25/32/40	Stainless steel/NBR	X10CrNi18-8				1.431
6	Gasket	EVRA 25	asbestos-free					
	Gasket	EVRA 32/40	Rubber	Cr				
7	Cover/thread plug	EVRA 25	Free-cutting steel	11SMnPb30				10277-3
	Cover/thread plug	EVRA 32/40	Stainless steel	X5CrNi17-10				10088
8	Gasket	EVRA 25	Rubber	CR				
9	Bolts	EVRA 25	Stainless steel	A2-70			3506	
10	Cover	EVRA 25	Cast-iron	GJS-400-18-LT				1563
11	Bolts	EVRA 25/32/40	Stainless steel	A2-70			3506	
12	Valve seat	EVRA 25	Teflon (PTFE)					

Rated capacity

Table 7: Rated capacity

Type	Rated capacity ⁽¹⁾ [kW]								Rated capacity ⁽²⁾ [kW]			
	Liquid				Suction vapour				Hot gas			
	R717	R22	R134a	R404A	R717	R22	R134a	R404A	R717	R22	R134a	R404A
EVRA 3	21.8	4.6	4.3	3.2				6.5	2.1	1.7	1.7	
EVRA/T 10	142	30.2	27.8	21.1	9	3.4	2.5	3.1	42.6	13.9	11	11.3
EVRA/T 15	256	54.4	50.1	38	16.1	6.2	4.4	5.5	76.7	24.9	19.8	20.3
EVRA/T 20	426	90.6	83.5	63.3	26.9	10.3	7.3	9.2	128	41.5	32.9	33.9
EVRA 25	947	201	186	141	59.7	22.8	16.3	20.4	284	92.3	73.2	75.3
EVRA 32	1515	322	297	225	95.5	36.5	26.1	32.6	454	148	117	120
EVRA 40	2368	503	464	351	149	57	40.8	51	710	231	183	188

⁽¹⁾ Rated liquid and suction vapour capacity is based on evaporating temperature $t_e = -10\text{ °C}$, liquid temperature ahead of valve $t_l = +25\text{ °C}$, and pressure drop across valve $\Delta p = 0.15\text{ bar}$.

⁽²⁾ Rated hot gas capacity is based on condensing temperature $t_c = +40\text{ °C}$, pressure drop across valve $\Delta p = 0.8\text{ bar}$, hot gas temperature $t_h = +65\text{ °C}$, and subcooling of refrigerant $\Delta t_{sub} = 4\text{ K}$.

Capacity

Table 8: Liquid capacity Q_l kW

R 717 (NH ₃)					
Type	Liquid capacity Q _l kW at pressure drop across valve Δp bar				
	0.1	0.2	0.3	0.4	0.5
EVRA 3	17.8	25.1	30.8	35.6	39.8
EVRA/T 10	116.0	164.0	201.0	232.0	259.0
EVRA/T 15	209.0	295.0	362.0	418.0	467.0
EVRA/T 20	348.0	492.0	603.0	696.0	778.0
EVRA 25	773.0	1093	1340	1547	1729
EVRA 32	1237	1749	2144	2475	2766
EVRA 40	1933	2734	3349	3867	4322

Table 9: Liquid capacity Q_l kW

R 22					
Type	Liquid capacity Q _l kW at pressure drop across valve Δp bar				
	0.1	0.2	0.3	0.4	0.5
EVRA 3	3.8	5.3	6.6	7.6	8.5
EVRA/T 10	24.7	34.9	42.7	49.3	55.1
EVRA/T 15	44.4	62.8	76.9	88.8	99.2
EVRA/T 20	73.9	105	128	148	165
EVRA 25	165	232	285	329	368
EVRA 32	263	372	455	526	588
EVRA 40	411	581	712	822	919

Table 10: Liquid capacity Q_l kW

R 134a					
Type	Liquid capacity Q _l kW at pressure drop across valve Δp bar				
	0.1	0.2	0.3	0.4	0.5
EVRA 3	3.5	4.9	6.0	7.0	7.8
EVRA/T 10	22.7	32.2	39.4	45.5	50.8
EVRA/T 15	40.9	57.9	70.9	81.8	91.5
EVRA/T 20	68.2	96.5	118	136	153
EVRA 25	152	214	263	303	339
EVRA 32	243	343	420	485	542
EVRA 40	379	536	656	758	847

Table 11: Liquid capacity Ql kW

R 404A					
Type	Liquid capacity Q _l kW at pressure drop across valve Δp bar				
	0.1	0.2	0.3	0.4	0.5
EVRA 3	2.6	3.7	4.6	5.3	5.9
EVRA/T 10	17.2	24.3	29.8	34.4	38.5
EVRA/T 15	31.0	43.8	53.7	62.0	69.3
EVRA/T 20	51.7	73.0	89.5	103	116
EVRA 25	115	162	199	230	257
EVRA 32	184	260	318	367	411
EVRA 40	287	406	497	574	642

NOTE:

Capacities are based on liquid temperature t_l = +25 °C ahead of valve, evaporating temperature t_e = -10 °C, and superheat 0 K.

Correction factors

When sizing valves, the plant capacity must be multiplied by a correction factor depending on liquid temperature t_l ahead of valve/evaporator. When the corrected capacity is known, the selection can be made from the table.

Table 12: Correction factors

t _v °C	-10	0	10	20	25	30	40	50
R 717 (NH ₃)	0.84	0.88	0.92	0.97	1	1.03	1.09	1.16
R 22, R 134a	0.76	0.81	0.88	0.96	1	1.05	1.16	1.31
R 404A	0.7	0.76	0.84	0.94	1	1.07	1.24	1.47

Capacity

Table 13: Suction vapour capacity Qe kW

R 717 (NH₃)							
Type	Pressure drop across valve Δp bar	Suction vapour capacity Q _e kW at evaporating temperature t _e °C					
		-40	-30	-20	-10	0	10
EVRA/T 10	0.1	3.4	4.5	5.9	7.3	8.9	10.6
	0.15	4.0	5.4	7.0	9.0	10.9	13.0
	0.2	4.5	6.1	7.9	10.0	12.6	15.0
EVRA/T 15	0.1	6.1	8.1	10.7	13.2	16.0	19.1
	0.15	7.2	9.7	12.5	16.1	19.6	23.4
	0.2	8.0	11.0	14.2	18.0	22.6	27.0
EVRA/T 20	0.1	10.2	13.5	17.8	21.9	26.6	31.9
	0.15	12.1	16.1	20.9	26.9	32.6	39.0
	0.2	13.4	18.3	23.7	29.9	37.7	45.1
EVRA 25	0.1	22.6	30.0	39.5	48.7	59.2	70.8
	0.15	26.7	35.9	46.3	59.7	72.5	86.7
	0.2	29.8	40.5	52.7	66.4	83.7	100
EVRA 32	0.1	36.2	47.8	63.2	77.9	94.7	113
	0.15	42.7	57.4	74.1	95.5	116	139
	0.2	47.7	64.8	84.3	106	134	160
EVRA 40	0.1	56.5	74.8	98.8	122	148	177
	0.15	66.8	89.8	116	149	181	217
	0.2	74.5	101.0	132	166	209	251

Table 14: Suction vapour capacity Qe kW

R 22							
Type	Pressure drop across valve Δp bar	Suction vapour capacity Q _e kW at evaporating temperature t _e °C					
		-40	-30	-20	-10	0	10
EVRA/T 10	0.1	1.4	1.8	2.3	2.8	3.4	4.0
	0.15	1.6	2.1	2.7	3.4	4.1	4.9
	0.2	1.8	2.4	3.1	3.8	4.8	5.6

Solenoid valve, type EVRA and EVRAT

R 22

Type	Pressure drop across valve Δp bar	Suction vapour capacity Q_e kW at evaporating temperature t_e °C					
		-40	-30	-20	-10	0	10
EVRA/T 15	0.1	2.5	3.2	4.1	5.0	6.1	7.2
	0.15	2.9	3.8	4.8	6.2	7.4	8.8
	0.2	3.3	4.3	5.5	6.8	8.6	10.2
EVRA/T 20	0.1	4.1	5.3	6.8	8.4	10.1	12
	0.15	4.9	6.4	8.1	10.3	12.3	14.7
	0.2	5.5	7.2	9.2	11.4	14.3	16.9
EVRA 25	0.1	9.1	11.8	15.2	18.6	22.4	26.6
	0.15	10.9	14.2	17.9	22.8	27.4	32.6
	0.2	12.2	16.1	20.4	25.3	31.7	37.6
EVRA 32	0.1	14.6	18.9	24.3	29.8	35.8	42.6
	0.15	17.4	22.7	28.8	36.5	43.8	52.2
	0.2	19.6	25.7	32.6	40.5	50.7	60.2
EVRA 40	0.1	22.8	29.5	38.1	46.5	56	66.5
	0.15	27.2	35.4	45	57	68.6	81.5
	0.2	30.5	40.2	51	63.3	79.2	94

NOTE:

Capacities are based on liquid temperature $t_l = +25$ °C ahead of evaporator. The table values refer to the evaporator capacity and are given as a function of evaporating temperature t_e and pressure drop Δp across valve. Capacities are based on dry, saturated vapour ahead of valve. During operation with superheated vapour ahead of valve, the capacities are reduced by 4% for each 10 K superheat.

Correction factors

When sizing valves, the evaporator capacity must be multiplied by a correction factor depending on liquid temperature t_l ahead of expansion valve. When the corrected capacity is known, the selection can be made from the table.

Table 15: Correction factors

t_v °C	-10	0	10	20	25	30	40	50
R 717 (NH ₃)	0.84	0.88	0.92	0.97	1	1.03	1.09	1.16
R 22	0.76	0.81	0.88	0.96	1	1.05	1.16	1.31

Capacity
Table 16: Suction vapour capacity Q_e kW
R 134a

Type	Pressure drop across valve Δp bar	Suction vapour capacity Q_e kW at evaporating temperature t_e °C					
		-40	-30	-20	-10	0	10
EVRA/T 10	0.1	0.87	1.2	1.6	2.1	2.6	3.2
	0.15	0.99	1.4	1.9	2.4	3.2	3.9
	0.2	1.1	1.6	2.1	2.8	3.5	4.5
EVRA/T 15	0.1	1.6	2.1	2.8	3.8	4.7	5.7
	0.15	1.8	2.5	3.4	4.4	5.7	7.0
	0.2	2.0	2.8	3.8	5.0	6.3	8.1
EVRA/T 20	0.1	2.6	3.6	4.7	6.3	7.8	9.5
	0.15	3.0	4.2	5.6	7.3	9.5	11.7
	0.2	3.3	4.7	6.4	8.3	10.5	13.5
EVRA 25	0.1	5.8	7.9	10.5	13.9	17.2	21.1
	0.15	6.6	9.3	12.5	16.3	21.1	25.9
	0.2	7.3	10.4	14.1	18.5	23.4	29.9
EVRA 32	0.1	9.3	12.6	16.8	22.2	27.7	33.8
	0.15	10.6	14.9	20.0	26.1	33.8	41.4
	0.2	11.7	16.6	22.6	29.6	37.4	47.8

Solenoid valve, type EVRA and EVRAT

		R 134a					
Type	Pressure drop across valve Δp bar	Suction vapour capacity Q_e kW at evaporating temperature t_e °C					
		-40	-30	-20	-10	0	10
EVRA 40	0.1	14.5	19.8	26.3	34.8	43.3	52.8
	0.15	16.5	23.3	31.3	40.8	52.8	64.8
	0.2	18.3	26.0	35.3	46.3	58.5	74.8

Table 17: Suction vapour capacity Q_e kW

		R 404A					
Type	Pressure drop across valve Δp bar	Suction vapour capacity Q_e kW at evaporating temperature t_e °C					
		-40	-30	-20	-10	0	10
EVRA/T 10	0.1	1.2	1.5	2.0	2.5	3.1	3.7
	0.15	1.4	1.8	2.4	3.1	3.8	4.6
	0.2	1.6	2.1	2.7	3.4	4.3	5.3
EVRA/T 15	0.1	2.1	2.7	3.6	4.5	5.5	6.6
	0.15	2.5	3.3	4.3	5.5	6.8	8.2
	0.2	2.8	3.7	4.9	6.1	7.8	9.5
EVRA/T 20	0.1	3.5	4.6	6.0	7.5	9.2	11.1
	0.15	4.1	5.5	7.1	9.2	11.3	13.6
	0.2	4.6	6.2	8.1	10.2	13	15.8
EVRA 25	0.1	7.7	10.1	13.3	16.6	20.4	24.6
	0.15	9.1	12.1	15.8	20.4	25	30.3
	0.2	10.3	13.8	18.0	22.7	28.8	35
EVRA 32	0.1	12.3	16.2	21.3	26.6	32.6	39.4
	0.15	14.6	19.4	25.3	32.6	40	48.5
	0.2	16.5	22.0	28.8	36.3	46.1	56
EVRA 40	0.1	19.3	25.3	33.3	41.5	51	61.5
	0.15	22.9	30.3	39.5	51	62.5	75.6
	0.2	25.8	34.5	45.0	56.8	72.1	87.5

NOTE:

Capacities are based on liquid temperature $t_l = +25$ °C ahead of evaporator. The table values refer to the evaporator capacity and are given as a function of evaporating temperature t_e and pressure drop Δp across valve. Capacities are based on dry, saturated vapour ahead of valve. During operation with superheated vapour ahead of valve, the capacities are reduced by 4% for each 10 K superheat.

Correction factors

When sizing valves, the evaporator capacity must be multiplied by a correction factor depending on liquid temperature t_l ahead of expansion valve. When the corrected capacity is known, the selection can be made from the table.

Table 18: Correction factors

t_v °C	-10	0	10	20	25	30	40	50
R 134a	0.76	0.81	0.88	0.96	1	1.05	1.16	1.31
R 404A	0.7	0.76	0.84	0.94	1	1.07	1.24	1.47

Capacity

Table 19: Hot gas capacity Qh kW

R 717 (NH ₃)						
Type	Pressure drop across valve Δp bar	Hot gas capacity Q _h kW				
		Evaporating temp. t _e = -10 °C. Hot gas temp. t _h = t _e + 25 °C. Subcooling Δt _{sub} = 4K				
		Condensing temperature t _c °C				
		20	30	40	50	60
EVRA 3	0.1	1.8	2.1	2.3	2.5	2.6
	0.2	2.6	2.9	3.2	3.5	3.7
	0.4	3.8	4.2	4.6	4.9	5.3
	0.8	5.1	6.0	6.5	7.1	7.6
	1.6	7.4	8.3	9.1	9.9	10.9
EVRA/T 10	0.1	12.0	13.4	14.7	16.0	17.2
	0.2	17.1	19.0	20.9	22.7	24.4
	0.4	24.5	27.1	29.7	32.2	34.7
	0.8	34.0	39.0	42.6	46.1	49.5
	1.6	48.5	53.8	59.1	64.3	71.3
EVRA/T 15	0.1	21.7	24.1	26.4	28.8	31.0
	0.2	30.8	34.2	37.5	40.8	44.0
	0.4	44.1	48.8	53.5	58.0	62.4
	0.8	61.2	70.3	76.7	83.0	89.1
	1.6	87.4	96.9	106	116.0	128.0
EVRA/T 20	0.1	36.1	40.1	44.0	48.0	51.7
	0.2	51.4	57.0	62.6	68.0	73.2
	0.4	73.5	81.3	89.1	96.7	104.0
	0.8	102	117	128	138.0	148.0
	1.6	146	161	177	193.0	214.0
EVRA 25	0.1	80.2	89.1	98.0	107.0	115.0
	0.2	114	127	139	151.0	163.0
	0.4	163	181	198	215.0	231.0
	0.8	227	260	284	307.0	330.0
	1.6	324	358	394	429.0	475.0
EVRA 32	0.1	128	143	157	171.0	184.0
	0.2	183	203	223	242.0	260.0
	0.4	261	289	317	344.0	370.0
	0.8	362	416	455	492.0	528.0
	1.6	518	574	631	688.0	761.0
EVRA 40	0.1	201	223	244	267.0	287.0
	0.2	286	317	348	378.0	407.0
	0.4	408	452	495	537.0	578.0
	0.8	566	650	710	769.0	825.0
	1.6	809	897	986	1074	1188

NOTE:

An increase in hot gas temperature t_h of 10 K, based on t_h = t_e + 25 °C, reduces valve capacity approx. 2% and vice versa. A change in evaporating temperature t_e changes valve capacity; see correction factor table below.

Correction factor

When sizing valves, the table value must be multiplied by a correction factor depending on evaporating temperature t_e.

Table 20: Correction factor

t _e °C	-40	-30	-20	-10	0	10
R 717 (NH ₃)	0.89	0.91	0.96	1	1.06	1.1

Capacity

Table 21: Hot gas capacity Qh kW

R 22						
Type	Pressure drop across valve Δp bar	Hot gas capacity Q_g kW				
		Evaporating temp. $t_e = -10$ °C. Hot gas temp. $t_h = t_e + 25$ °C. Subcooling $\Delta t_{sub} = 4K$				
		Condensing temperature t_c °C				
		20	30	40	50	60
EVRA 3	0.1	0.68	0.72	0.76	0.78	0.79
	0.2	0.97	1.0	1.1	1.1	1.1
	0.4	1.4	1.5	1.5	1.6	1.6
	0.8	1.9	2.0	2.1	2.3	2.3
	1.6	2.7	2.9	3.0	3.1	3.2
EVRA/T 10	0.1	4.4	4.7	4.9	5.1	5.2
	0.2	6.3	6.7	7.0	7.2	7.3
	0.4	9.0	9.6	10.0	10.3	10.4
	0.8	12.4	13.2	13.9	14.7	14.9
	1.6	17.5	18.6	19.6	20.2	20.5
EVRA/T 15	0.1	8.0	8.5	8.9	9.2	9.3
	0.2	11.4	12.1	12.6	13.0	13.2
	0.4	16.3	17.2	18.0	18.5	18.7
	0.8	22.3	23.1	24.9	26.5	26.8
	1.6	31.5	33.5	35.2	36.4	36.9
EVRA/T 20	0.1	13.3	14.1	14.8	15.3	15.5
	0.2	19.0	20.1	21.0	21.7	22.0
	0.4	27.1	28.7	30.0	30.9	31.2
	0.8	37.1	38.4	41.5	44.2	44.6
	1.6	52.5	55.9	58.6	60.6	61.5
EVRA 25	0.1	29.6	31.4	32.9	34.0	34.4
	0.2	42.1	44.6	46.7	48.2	48.8
	0.4	60.2	63.8	66.6	68.6	69.4
	0.8	82.5	87.9	92.3	98.2	99.2
	1.6	117.0	124.0	130.0	135.0	137.0
EVRA 32	0.1	47.4	50.2	52.6	54.4	55.0
	0.2	67.4	71.4	74.7	77.1	78.1
	0.4	96.3	102.0	107.0	110.0	111.0
	0.8	132.0	140.0	148.0	157.0	159.0
	1.6	187.0	199.0	209.0	216.0	219.0
EVRA 40	0.1	74.0	78.5	82.3	85.0	86.0
	0.2	105.0	112.0	117.0	121.0	122.0
	0.4	151.0	159.0	167.0	172.0	174.0
	0.8	206.0	222.0	231.0	246.0	248.0
	1.6	291.0	310.0	326.0	337.0	342.0

NOTE:

An increase in hot gas temperature t_h of 10 K, based on $t_h = t_c + 25$ °C, reduces valve capacity approx. 2% and vice versa. A change in evaporating temperature t_e changes valve capacity; see correction factor table below.

Correction factor

When sizing valves, the table value must be multiplied by a correction factor depending on evaporating temperature t_e .

Table 22: Correction factor

t_e °C	-40	-30	-20	-10	0	10
R 22	0.9	0.94	0.97	1	1.03	1.05

Capacity

Table 23: Hot gas capacity Qh kW

R 134a						
Type	Pressure drop across valve Δp bar	Hot gas capacity Q_g kW				
		Evaporating temp. $t_e = -10$ °C. Hot gas temp. $t_h = t_c + 25$ °C. Subcooling $\Delta t_{sub} = 4K$				
		Condensing temperature t_c °C				
		20	30	40	50	60
EVRA 3	0.1	0.54	0.57	0.6	0.61	0.6
	0.2	0.77	0.82	0.85	0.86	0.85
	0.4	1.1	1.2	1.2	1.2	1.2
	0.8	1.5	1.6	1.7	1.8	1.8
	1.6	2.2	2.3	2.4	2.5	2.4
EVRA/T 10	0.1	3.5	3.7	3.9	4.0	3.9
	0.2	5.0	5.3	5.5	5.6	5.6
	0.4	7.0	7.7	7.9	8.0	7.9
	0.8	9.9	10.5	11.0	11.6	11.4
	1.6	14.3	15.1	15.7	16.0	15.9
EVRA/T 15	0.1	6.4	6.7	7.0	7.1	7.1
	0.2	9.1	9.6	10.0	10.1	10.0
	0.4	12.6	13.8	14.2	14.4	14.3
	0.8	17.9	19.0	19.8	20.8	20.5
	1.6	25.7	27.2	28.2	28.8	28.6
EVRA/T 20	0.1	10.6	11.2	11.7	11.8	11.8
	0.2	15.1	16.0	16.6	16.8	16.7
	0.4	21.0	22.9	23.7	24.0	23.8
	0.8	29.8	31.6	33.0	34.7	34.2
	1.6	42.8	45.3	47.1	47.9	47.6
EVRA 25	0.1	23.6	24.9	25.9	26.4	26.2
	0.2	33.6	35.5	36.8	37.4	37.1
	0.4	46.6	51.0	52.7	53.4	52.9
	0.8	66.2	70.2	73.2	77.0	76.0
	1.6	95.2	101.0	105.0	107.0	106.0
EVRA 32	0.1	37.6	39.8	41.4	42.1	41.8
	0.2	53.8	56.8	58.9	59.8	59.4
	0.4	74.7	81.6	84.3	85.4	84.6
	0.8	106.0	112.0	117.0	123.0	122.0
	1.6	152.0	161.0	167.0	170.0	169.0
EVRA 40	0.1	58.8	62.3	64.7	65.8	65.3
	0.2	84.1	88.8	92.1	93.5	92.8
	0.4	117.0	127.0	132.0	134.0	132.0
	0.8	166.0	176.0	183.0	192.0	190.0
	1.6	238.0	252.0	262.0	266.0	265.0

NOTE:

An increase in hot gas temperature t_h of 10 K, based on $t_h = t_c + 25$ °C, reduces valve capacity approx. 2% and vice versa. A change in evaporating temperature t_e changes valve capacity; see correction factor table below.

Correction factor

When sizing valves, the table value must be multiplied by a correction factor depending on evaporating temperature t_e .

Table 24: Correction factor

t_e °C	-40	-30	-20	-10	0	10
R 134a	0.88	0.92	0.98	1	1.04	1.08

Capacity

Table 25: Hot gas capacity Qh kW

R 404A						
Type	Pressure drop across valve Δp bar	Hot gas capacity Q_g kW				
		Evaporating temp. $t_e = -10$ °C. Hot gas temp. $t_h = t_c + 25$ °C. Subcooling $\Delta t_{sub} = 4$ K				
		Condensing temperature t_c °C				
		20	30	40	50	60
EVRA 3	0.1	0.62	0.63	0.62	0.59	0.54
	0.2	0.87	0.89	0.88	0.83	0.76
	0.4	1.2	1.3	1.3	1.2	1.1
	0.8	1.7	1.7	1.7	1.7	1.5
	1.6	2.4	2.5	2.4	2.3	2.1
EVRA/T 10	0.1	4.0	4.1	4.0	3.8	3.5
	0.2	5.7	5.8	5.7	5.5	5.0
	0.4	8.1	8.2	8.2	7.8	7.0
	0.8	11.1	11.4	11.3	11.1	10.1
	1.6	15.7	16.0	15.8	15.2	13.9
EVRA/T 15	0.1	7.3	7.4	7.3	6.9	6.3
	0.2	10.2	10.4	10.3	9.8	8.9
	0.4	14.6	14.8	14.7	14.0	12.7
	0.8	20.1	20.4	20.3	20.0	18.1
	1.6	28.3	28.8	28.4	27.4	25.0
EVRA/T 20	0.1	12.1	12.3	12.1	11.5	10.5
	0.2	17.1	17.3	17.2	16.3	14.9
	0.4	24.4	24.7	24.5	23.3	21.1
	0.8	33.4	34.0	33.9	33.3	30.2
	1.6	47.1	48.0	47.4	45.6	41.6
EVRA 25	0.1	26.8	27.4	26.9	25.6	23.3
	0.2	37.9	38.4	38.2	36.3	33.0
	0.4	54.2	54.9	54.5	51.7	47.0
	0.8	74.2	75.6	75.3	74.0	67.2
	1.6	105.0	107.0	105.0	101.0	92.5
EVRA 32	0.1	43.0	43.8	43.0	40.9	37.3
	0.2	60.6	61.4	61.1	58.1	52.8
	0.4	86.7	87.8	87.2	82.7	75.2
	0.8	119.0	121.0	120.0	118.0	107.0
	1.6	167.0	171.0	168.0	162.0	148.0
EVRA 40	0.1	67.0	68.5	67.3	64.0	58.3
	0.2	94.8	96.0	95.5	90.8	82.5
	0.4	136.0	137.0	136.0	129.0	117.0
	0.8	186.0	189.0	188.0	185.0	168.0
	1.6	262.0	266.0	263.0	253.0	231.0

NOTE:

An increase in hot gas temperature t_h of 10 K, based on $t_h = t_c + 25$ °C, reduces valve capacity approx. 2% and vice versa. A change in evaporating temperature t_e changes valve capacity; see correction factor table below.

Correction factor

When sizing valves, the table value must be multiplied by a correction factor depending on evaporating temperature t_e .

Table 26: Correction factor

t_e °C	-40	-30	-20	-10	0	10
R 404A	0.86	0.88	0.93	1	1.03	1.07

Capacity

Table 27: Hot gas capacity Gh kg/s

R 717 (NH ₃)											
Type	Hot gas temperature t _h °C	Condensing temperature t _k °C	Hot gas capacity G _h kg/s at pressure drop across valve Δp bar								
			0.5	1	2	3	4	5	6	7	8
EVRA 3	90	25	0.003	0.005	0.006	0.007	0.007	0.007	0.007	0.007	0.007
	90	35	0.004	0.005	0.007	0.009	0.009	0.01	0.01	0.01	0.01
	90	45	0.005	0.006	0.009	0.01	0.011	0.012	0.013	0.013	0.013
EVRA/T 10	90	25	0.022	0.03	0.04	0.045	0.048	0.048	0.048	0.048	0.048
	90	35	0.026	0.036	0.048	0.056	0.061	0.064	0.065	0.065	0.065
	90	45	0.03	0.041	0.056	0.066	0.074	0.079	0.083	0.085	0.086
EVRA/T 15	90	25	0.04	0.054	0.072	0.081	0.086	0.087	0.087	0.087	0.087
	90	35	0.046	0.064	0.086	0.1	0.109	0.115	0.117	0.117	0.117
	90	45	0.053	0.074	0.101	0.12	0.133	0.142	0.149	0.153	0.155
EVRA/T 20	90	25	0.066	0.09	0.12	0.12	0.144	0.145	0.145	0.145	0.145
	90	35	0.077	0.107	0.144	0.167	0.182	0.191	0.195	0.195	0.195
	90	45	0.089	0.124	0.169	0.199	0.211	0.237	0.248	0.255	0.258
EVRA 25	90	25	0.143	0.197	0.26	0.296	0.313	0.316	0.316	0.316	0.316
	90	35	0.168	0.232	0.313	0.364	0.397	0.417	0.425	0.425	0.425
	90	45	0.194	0.269	0.368	0.434	0.482	0.516	1.54	0.555	0.561
EVRA 32	90	25	0.233	0.322	0.424	0.483	0.511	0.516			
	90	35	0.274	0.379	0.511	0.594	0.648	0.681	0.694		
	90	45	0.316	0.439	0.601	0.709	0.787	0.842	0.882	0.906	0.916
EVRA 40	90	25	0.362	0.503	0.663	0.755	0.798	0.806			
	90	35	0.429	0.592	0.798	0.929	1.013	1.064	1.084		
	90	45	0.495	0.686	0.939	1.107	1.23	1.316	1.378	1.416	1.431

Table 28: Hot gas capacity Gh kg/s

R 22											
Type	Hot gas temperature t _h °C	Condensing temperature t _k °C	Hot gas capacity G _h kg/s at pressure drop across valve Δp bar								
			0.5	1	2	3	4	5	6	7	8
EVRA 3	90	25	0.008	0.011	0.014	0.016	0.017	0.017	0.017	0.017	0.017
	90	35	0.009	0.012	0.017	0.019	0.021	0.022	0.022	0.022	0.022
	90	45	0.01	0.014	0.019	0.022	0.025	0.026	0.027	0.028	0.028
EVRA/T 10	90	25	0.051	0.069	0.092	0.104	0.109	0.111	0.111	0.111	0.111
	90	35	0.058	0.08	0.108	0.125	0.136	0.142	0.144	0.144	0.144
	90	45	0.066	0.092	0.125	0.146	0.162	0.172	0.179	0.183	0.183
EVRA/T 15	90	25	0.091	0.125	0.165	0.187	0.197	0.199	0.199	0.199	0.199
	90	35	0.105	0.144	0.194	0.225	0.244	0.256	0.258	0.258	0.258
	90	45	0.119	0.165	0.224	0.263	0.291	0.31	0.322	0.329	0.33
EVRA/T 20	90	25	0.152	0.208	0.275	0.311	0.328	0.332	0.332	0.332	0.332
	90	35	0.174	0.241	0.323	0.375	0.407	0.425	0.431	0.431	0.431
	90	45	0.193	0.275	0.374	0.439	0.485	0.516	0.537	0.548	0.55
EVRA 25	90	25	0.331	0.453	0.599	0.677	0.715	0.722	0.722	0.722	0.722
	90	35	0.38	0.524	0.704	0.816	0.886	0.925	0.938	0.938	0.938
	90	45	0.431	0.598	0.814	0.956	1.056	1.125	1.169	1.192	1.197
EVRA 32	90	25	0.539	0.739	0.976	1.106	1.168	1.179			
	90	35	0.619	0.856	1.15	1.331	1.446	1.509	1.531		
	90	45	0.704	0.978	1.329	1.562	1.723	1.837	1.909	1.947	1.955
EVRA 40	90	25	0.843	1.155	1.525	1.728	1.825	1.843			
	90	35	0.968	1.338	1.798	2.08	2.26	2.358	2.393		
	90	45	1.1	1.528	2.078	2.44	2.693	2.87	2.383	3.043	3.055

NOTE:

An increase in hot gas temperature t_h of 10 K reduces valve capacity approx. 2% and vice versa.

Capacity

Table 29: Hot gas capacity Gh kg/s

R 134a											
Type	Hot gas temperature t_h °C	Condensing temperature t_k °C	Hot gas capacity G_h kg/s at pressure drop across valve Δp bar								
			0.5	1	2	3	4	5	6	7	8
EVRA 3	60	25	0.007	0.009	0.011	0.012	0.012				
	60	35	0.009	0.011	0.014	0.016	0.016	0.016	0.016		
	60	45	0.01	0.012	0.018	0.02	0.021	0.021	0.021	0.021	0.021
EVRA/T 10	60	25	0.048	0.06	0.074	0.077	0.077				
	60	35	0.055	0.071	0.092	0.103	0.104	0.104			
	60	45	0.06	0.084	0.111	0.127	0.134	0.135	0.135	0.135	0.135
EVRA/T 15	60	25	0.081	0.108	0.134	0.14	0.14				
	60	35	0.094	0.129	0.166	0.192	0.187	0.187	0.187		
	60	45	0.108	0.151	0.2	0.228	0.241	0.244	0.244	0.244	0.244
EVRA/T 20	60	25	0.134	0.18	0.223	0.233	0.233				
	60	35	0.157	0.215	0.276	0.307	0.312	0.312	0.312		
	60	45	0.181	0.252	0.333	0.381	0.403	0.407	0.407	0.407	0.407
EVRA 25	60	25	0.292	0.391	0.486	0.506	0.506				
	60	35	0.341	0.467	0.602	0.668	0.679	0.679	0.679		
	60	45	0.393	0.549	0.725	0.83	0.876	0.885	0.885	0.885	0.885
EVRA 32	60	25	0.478	0.638	0.793	1.826	0.826				
	60	35	0.556	0.763	0.994	1.091	1.108	1.108	1.108	1.108	
	60	45	0.641	0.897	1.197	1.354	1.432	1.446	1.446	1.446	1.446
EVRA 40	60	25	0.747	0.998	1.24	1.291	1.291				
	60	35	0.87	1.192	1.553	1.704	1.731	1.731	1.731		
	60	45	1.002	1.402	1.87	2.117	2.237	2.259	2.259	2.259	2.259

Table 30: Hot gas capacity Gh kg/s

R 404A											
Type	Hot gas temperature t_h °C	Condensing temperature t_k °C	Hot gas capacity G_h kg/s at pressure drop across valve Δp bar								
			0.5	1	2	3	4	5	6	7	8
EVRA 3	60	25	0.01	0.013	0.018	0.021	0.022	0.023	0.023	0.023	0.023
	60	35	0.011	0.015	0.02	0.024	0.027	0.028	0.029	0.029	0.03
	60	45	0.012	0.017	0.023	0.028	0.032	0.034	0.035	0.036	0.037
EVRA/T 10	60	25	0.063	0.087	0.116	0.134	0.145	0.148	0.149	0.149	0.149
	60	35	0.072	0.1	0.134	0.158	0.174	0.184	0.19	0.19	0.192
	60	45	0.081	0.112	0.153	0.182	0.203	0.228	0.228	0.237	0.239
EVRA/T 15	60	25	0.113	0.157	0.21	0.242	0.26	0.267	0.269	0.269	0.269
	60	35	0.129	0.18	0.242	0.285	0.313	0.332	0.341	0.342	0.346
	60	45	0.146	0.202	0.275	0.327	0.365	0.393	0.411	0.424	0.431
EVRA/T 20	60	25	0.189	0.262	0.35	0.403	0.433	0.445	0.449	0.449	0.449
	60	35	0.215	0.3	0.404	0.474	0.521	0.552	0.569	0.57	0.576
	60	45	0.243	0.337	0.459	0.545	0.609	0.656	0.684	0.707	0.719
EVRA 25	60	25	0.411	0.57	0.763	0.878	0.942	0.969	0.978	0.978	0.978
	60	35	0.468	0.653	0.881	1.032	1.136	1.203	1.239	1.241	1.253
	60	45	0.529	0.734	1.0	1.188	1.326	1.43	1.49	1.539	1.566
EVRA 32	60	25	0.672	0.931	1.245	1.432	1.539	1.581	1.581	1.581	1.581
	60	35	0.765	1.069	1.436	1.686	1.854	1.964	2.022	2.025	2.025
	60	45	0.862	1.198	1.632	1.939	1.836	2.34	2.433	2.513	2.557
EVRA 40	60	25	1.05	1.454	1.946	2.238	2.406	2.471	2.471	2.471	2.471
	60	35	1.195	1.657	2.245	2.635	2.897	3.068	3.161	3.166	3.166
	60	45	1.348	1.873	2.55	3.03	3.384	3.65	3.801	3.926	3.995

NOTE:

An increase in hot gas temperature t_h of 10 K reduces valve capacity approx. 2% and vice versa.

Dimensions and weights

Table 31: EVRA 3 and EVRA 3 – 20

EVRA 3 Coil with cable	EVRA 3 – 20 Coil with DIN plugs	EVRA 3 – 20 Coil with terminal box

Table 32: EVRA/T 10 – 2 and EVRA 10

EVRA/T 10 – 20 Coil with terminal box	EVRA 10 Coil with terminal box

Table 33: EVRA 3 and EVRA/T 10 - 20

Type	H ₁	H ₂	H ₃	H ₄	L	L ₁	L ₃ max.		B	B ₁ max.	Weight ⁽¹⁾
							10 W	12 W 20 W			
							mm	mm			
EVRA 3		84	19		124	65			80	68	1.2
EVRA/T 10	22	100		81	130	68	75	85	80	68	1.7
EVRA/T 15		100		81	130	68			80	68	1.8
EVRA/T 20		110		77	155	85			96	68	2.7

⁽¹⁾ With coil, without flanges

Solenoid valve, type EVRA and EVRAT

Weight of coil:

10 W: approx. 0.3 kg

12 and 20 W: approx. 0.5 kg

Weight of flange set:

For EVRA 3, 10 and 15: 0.6 kg

For EVRA 20: 0.9 kg

Table 34: EVRA 25, EVRA 32 and EVRA 40 Coil with terminal box

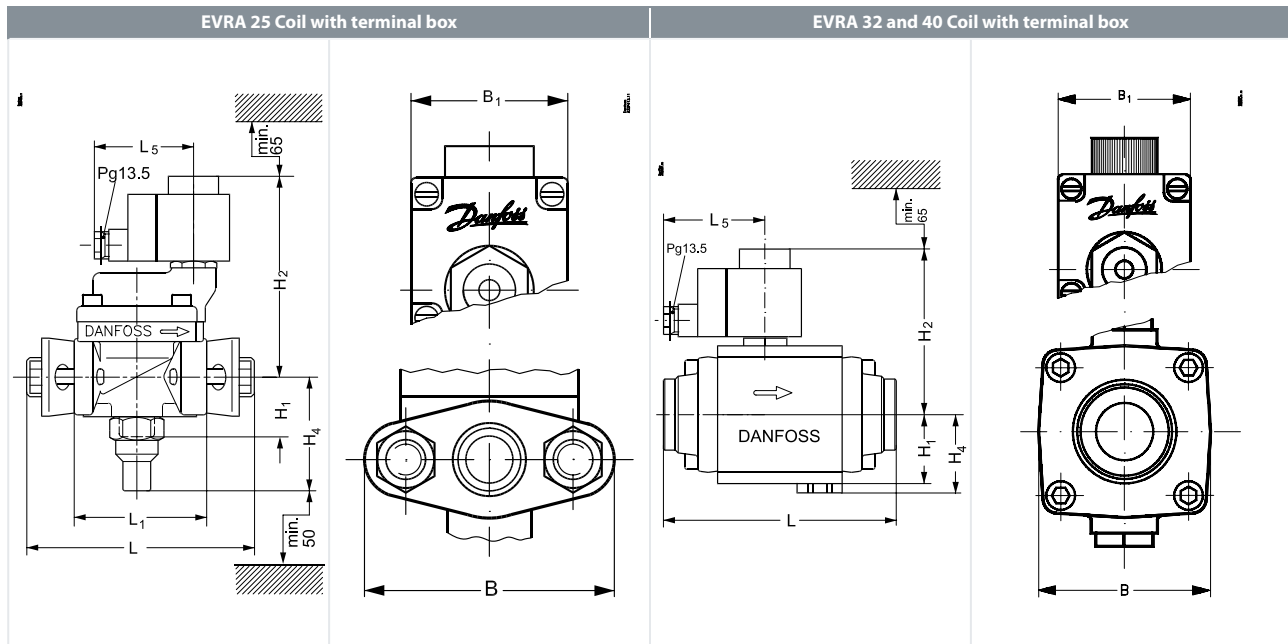

Table 35: EVRA 25, EVRA 32 and EVRA 40 Coil with cable and DIN plugs



Table 36: EVRA 25, EVRA 32 and EVRA 40

Type	H ₁	H ₂	H ₃	H ₄	L	L ₁	L ₅ max.		B	B ₁ max.	Weight ⁽²⁾
							10 W	12 W 20 W			
							mm	mm			
EVRA 25	46	141		78	162	92			95	68	3.0
EVRA 32	47	115		53	175		75	85	80	68	4.0
EVRA 40	47	115		53	175				80	68	4.0

⁽²⁾ With coil, without flanges

Weight of coil:

10 W: approx. 0.3 kg

12 and 20 W: approx. 0.5 kg

Weight of flange set:

For EVRA 25: 0.9 kg

Ordering

Ordering valve with coil

Figure 3: Valve with coil

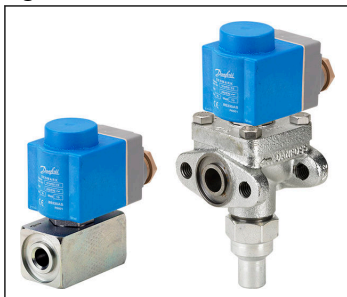

Table 37: Ordering valve with coil

Type	Manual Stem	Inlet connection type	Orifice size [mm]	Max OPD 10W AC [bar]	Max OPD 20W DC [bar]	Coil type	Coil connection	Supply voltage [V] AC	Frequency [Hz]	Power consumption [W]	Singlepack/Multipack (12 pcs.)	Code number
EVRA 3	No	Flange ⁽¹⁾	3	21	14	BF230AS	Cable (1 m/3.3 ft)	220 - 230	50	10	Multipack	032F310231
EVRA 3	No	Flange ⁽¹⁾	3	21	14	BE230AS	Connection Box	220 - 230	50	10	Multipack	032F310331
EVRA 3	No	Flange ⁽¹⁾	3	21	14	BE230CS	Connection Box	220 - 230	50/60	10	Multipack	032F310332
EVRA 10	No	Flange ⁽¹⁾	10	21	18	BE230AS	Connection Box	220 - 230	50	10	Multipack	032F620831
EVRA 10	Yes	Flange ⁽¹⁾	10	21	18	BF230AS	Cable (1 m/3.3 ft)	220 - 230	50	10	Singlepack	032F621231
EVRA 10	Yes	Flange ⁽¹⁾	10	21	18	BE230AS	Connection Box	220 - 230	50	10	Singlepack	032F621331
EVRA 10	Yes	Flange ⁽¹⁾	10	21	18	BE230CS	Connection Box	220 - 230	50/60	10	Singlepack	032F621332
EVRA 15	No	Flange ⁽¹⁾	15	21	18	BF230AS	Cable (1 m/3.3 ft)	220 - 230	50	10	Singlepack	032F621731
EVRA 15	No	Flange ⁽¹⁾	15	21	18	BF230CS	Cable (1 m/3.3 ft)	220 - 230	50/60	10	Singlepack	032F621732
EVRA 15	No	Flange ⁽¹⁾	15	21	18	BE230AS	Connection Box	220 - 230	50	10	Singlepack	032F621831
EVRA 15	No	Flange ⁽¹⁾	15	21	18	BE230CS	Connection Box	220 - 230	50/60	10	Singlepack	032F621832
EVRA 20	No	Flange ⁽¹⁾	20	21	13	BF230AS	Cable (1 m/3.3 ft)	220 - 230	50	10	Singlepack	032F622231
EVRA 20	No	Flange ⁽¹⁾	20	21	13	BE230AS	Connection Box	220 - 230	50	10	Singlepack	032F622331
EVRA 20	No	Flange ⁽¹⁾	20	21	13	BE230CS	Connection Box	220 - 230	50/60	10	Singlepack	032F622332
EVRA 25	Yes	Flange ⁽¹⁾	25	21	14	BE230CS	Connection Box	220 - 230	50/60	10	Singlepack	032F803432

⁽¹⁾ Includes flange gaskets and bolts. For ordering flanges; please download the data sheet AI249786497379 from www.danfoss.com

Ordering valve without coil

Figure 4: valve without coil



Table 38: Ordering valve without coil

Type	Manual Stem	Inlet connection type	Inlet size [in]	Orifice size [mm]	Max OPD 10W AC [bar]	Max OPD 12W AC [bar]	Max OPD 20W DC [bar]	Required coil type ⁽¹⁾	Singlepack/ Multipack (12 pcs.)	Code number
EVRA 3	No	Flange ⁽²⁾		3	21	25	14	AC / DC	Multipack	032F3050
EVRA 10	Yes	Flange ⁽²⁾		10	21	25	18	AC / DC	Singlepack	032F6210
EVRA 10	No	Flange ⁽²⁾		10	21	25	18	AC / DC	Singlepack	032F6211
EVRAT 10	Yes	Flange ⁽²⁾		10	14	21	16	AC / DC	Singlepack	032F6214
EVRA 15	Yes	Flange ⁽²⁾		15	21	25	18	AC / DC	Singlepack	032F6215
EVRAT 15	Yes	Flange ⁽²⁾		15	14	21	16	AC / DC	Singlepack	032F6216
EVRAT 20	Yes	Flange ⁽²⁾		20	14	21	13	AC / DC	Singlepack	032F6219
EVRA 20	Yes	Flange ⁽²⁾		20	21	25	13	AC	Singlepack	032F6220
EVRA 20	Yes	Flange ⁽²⁾		20	19	21	16	AC / DC	Singlepack	032F6221
EVRA 25	Yes	Flange ⁽²⁾		25	21	25	14	AC / DC	Singlepack	032F6225
EVRA 25	No	Flange ⁽²⁾		25	21	25	14	AC / DC	Singlepack	032F6226
EVRA 32	Yes	Butt weld DIN	1¼	22.2	21	25	14	AC / DC	Singlepack	042H1126
EVRA 32	No	Butt weld DIN	1¼	22.2	21	25	14	AC / DC	Singlepack	042H1127
EVRA 40	Yes	Butt weld DIN	1½	25.4	21	25	14	AC / DC	Singlepack	042H1128
EVRA 40	No	Butt weld DIN	1½	25.4	21	25	14	AC / DC	Singlepack	042H1129
EVRA 32	Yes	Butt weld DIN	1½	22.2	21	25	14	AC / DC	Singlepack	042H1131
EVRA 40	Yes	Butt weld DIN	2	25.4	21	25	14	AC / DC	Singlepack	042H1132
EVRA 32	Yes	Butt weld ANSI 36.10	1¼	22.2	21	25	14	AC / DC	Singlepack	042H1140
EVRA 32	Yes	Butt weld ANSI 36.10	1½	22.2	21	25	14	AC / DC	Singlepack	042H1141
EVRA 40	Yes	Butt weld ANSI 36.10	1½	25.4	21	25	14	AC / DC	Singlepack	042H1142
EVRA 40	Yes	Butt weld ANSI 36.10	2	25.4	21	25	14	AC / DC	Singlepack	042H1143

⁽¹⁾ For ordering coils; please download the data sheet AI237186440089 from www.danfoss.com

⁽²⁾ Includes flange gaskets and bolts. For ordering flanges; please download the data sheet AI249786497379 from www.danfoss.com

Certificates, declarations, and approvals

The list contains all certificates, declarations, and approvals for this product type. Individual code number may have some or all of these approvals, and certain local approvals may not appear on the list.

Some approvals may change over time. You can check the most current status at danfoss.com or contact your local Danfoss representative if you have any questions.

Table 39: Valid approvals

Type	File name	Document type	Document topic	Approval authority
EVRA(T)	RU Д-ДК.БЛ08.В.03639	EAC Declaration	Machinery & Equipment	EAC
	0045 202 1204 Z 00354 19 D 001(00)	Pressure - Safety Certificate		TÜV
	RU Д-ДК.БЛ08.В.00189_18	EAC Declaration	EMC	EAC
	RU Д-ДК.РА01.В.71727_20	EAC Declaration	PED	EAC
	MD 033F0691.AE	Manufacturers Declaration	RoHS	Danfoss
	MD 033F0686.AH	Manufacturers Declaration	PED	Danfoss
	033F0474.AC	Manufacturers Declaration	ATEX	Danfoss
	EU 033F0685.AK	EU Declaration	EMCD/PED	Danfoss
	RMRS 19.10034.262	Marine - Safety Certificate		RMRS
	DNV GL TAA0000085 Rev. 2	Marine - Safety Certificate		DNV GL
	UL SA7200	Mechanical - Safety Certificate		
	TSSA CRN.0C14029.523467890YTN	Pressure - Safety Certificate	CRN	TSSA

Online support

Danfoss offers a wide range of support along with our products, including digital product information, software, mobile apps, and expert guidance. See the possibilities below.

The Danfoss Product Store



The Danfoss Product Store is your one-stop shop for everything product related—no matter where you are in the world or what area of the cooling industry you work in. Get quick access to essential information like product specs, code numbers, technical documentation, certifications, accessories, and more.

Start browsing at store.danfoss.com.

Find technical documentation



Find the technical documentation you need to get your project up and running. Get direct access to our official collection of data sheets, certificates and declarations, manuals and guides, 3D models and drawings, case stories, brochures, and much more.

Start searching now at www.danfoss.com/en/service-and-support/documentation.

Danfoss Learning



Danfoss Learning is a free online learning platform. It features courses and materials specifically designed to help engineers, installers, service technicians, and wholesalers better understand the products, applications, industry topics, and trends that will help you do your job better.

Create your Danfoss Learning account for free at www.danfoss.com/en/service-and-support/learning.

Get local information and support



Local Danfoss websites are the main sources for help and information about our company and products. Find product availability, get the latest regional news, or connect with a nearby expert—all in your own language.

Find your local Danfoss website here: www.danfoss.com/en/choose-region.

Spare Parts



Get access to the Danfoss spare parts and service kit catalog right from your smartphone. The app contains a wide range of components for air conditioning and refrigeration applications, such as valves, strainers, pressure switches, and sensors.

Download the Spare Parts app for free at www.danfoss.com/en/service-and-support/downloads.

Coolselector®2 - find the best components for you HVAC/R system



Coolselector®2 makes it easy for engineers, consultants, and designers to find and order the best components for refrigeration and air conditioning systems. Run calculations based on your operating conditions and then choose the best setup for your system design.

Download Coolselector®2 for free at coolselector.danfoss.com.

Danfoss A/S

Climate Solutions • danfoss.com • +45 7488 2222

Any information, including, but not limited to information on selection of product, its application or use, product design, weight, dimensions, capacity or any other technical data in product manuals, catalogues descriptions, advertisements, etc. and whether made available in writing, orally, electronically, online or via download, shall be considered informative, and is only binding if and to the extent, explicit reference is made in a quotation or order confirmation. Danfoss cannot accept any responsibility for possible errors in catalogues, brochures, videos and other material. Danfoss reserves the right to alter its products without notice. This also applies to products ordered but not delivered provided that such alterations can be made without changes to form, fit or function of the product.

All trademarks in this material are property of Danfoss A/S or Danfoss group companies. Danfoss and the Danfoss logo are trademarks of Danfoss A/S. All rights reserved.